

# FEAL

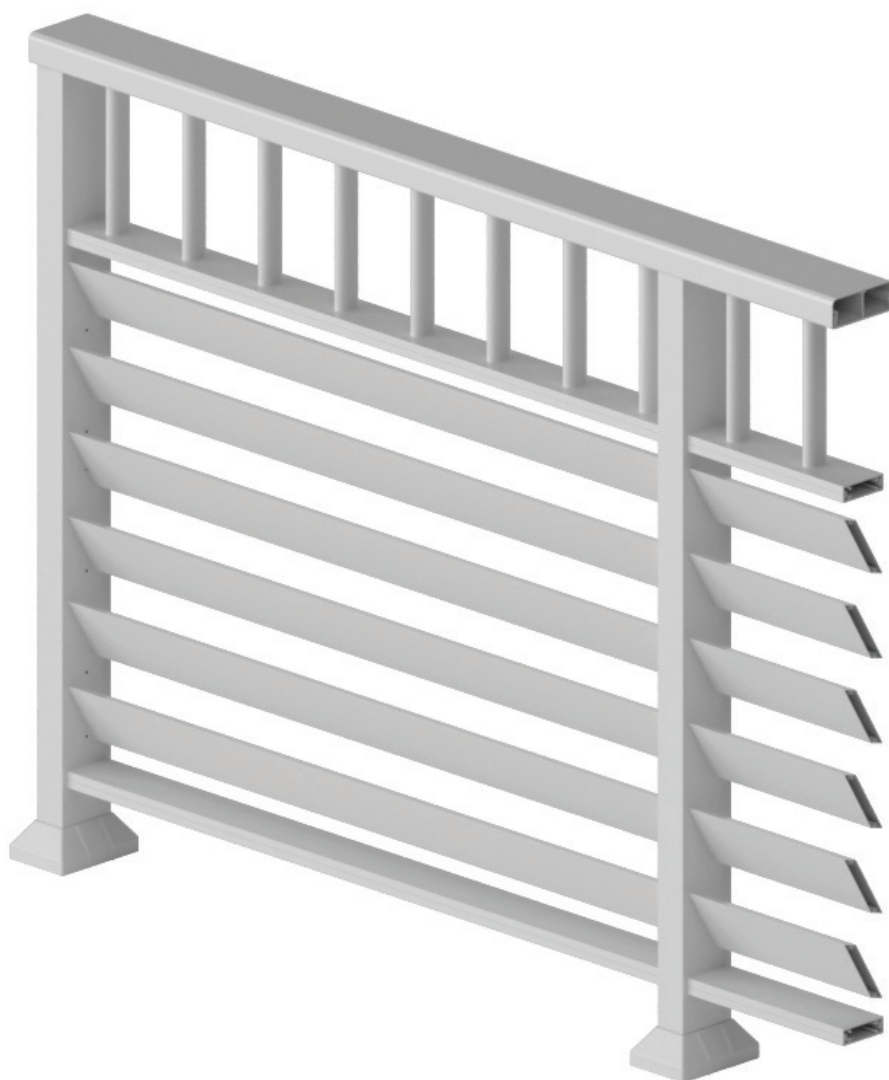

OF 80

ALUMINIJSKA OGRADA  
*ALUMINIUM FENCE*



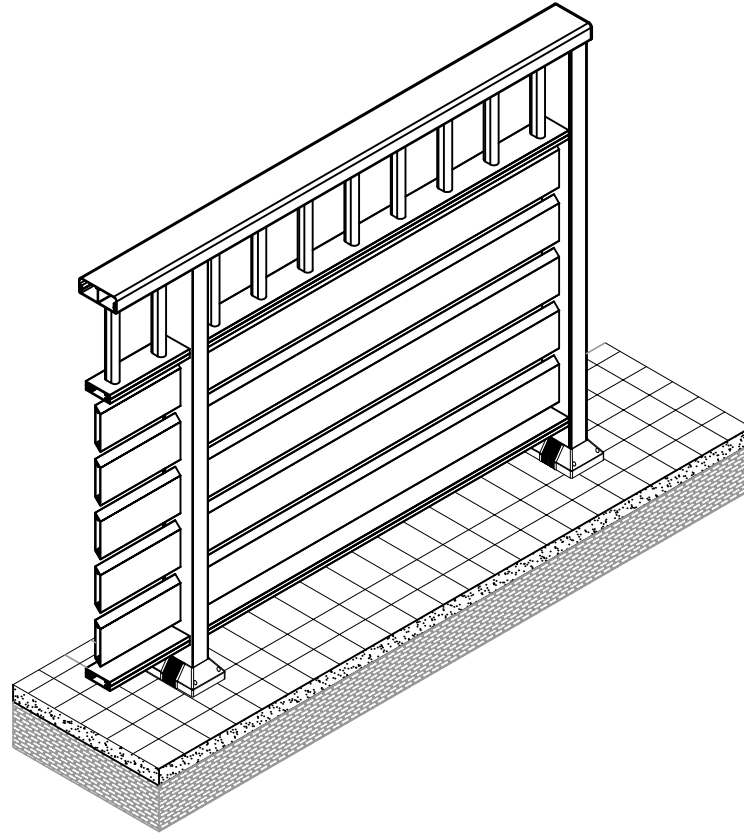

**Ograda OF 80**

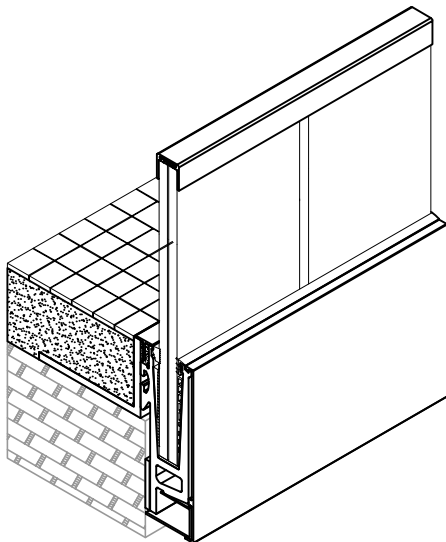

**Ograda OF 100**

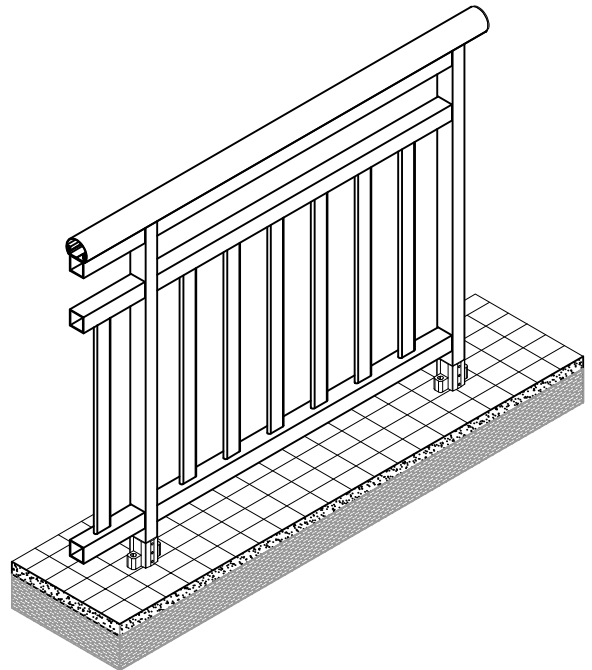

**Ograda OF 60**



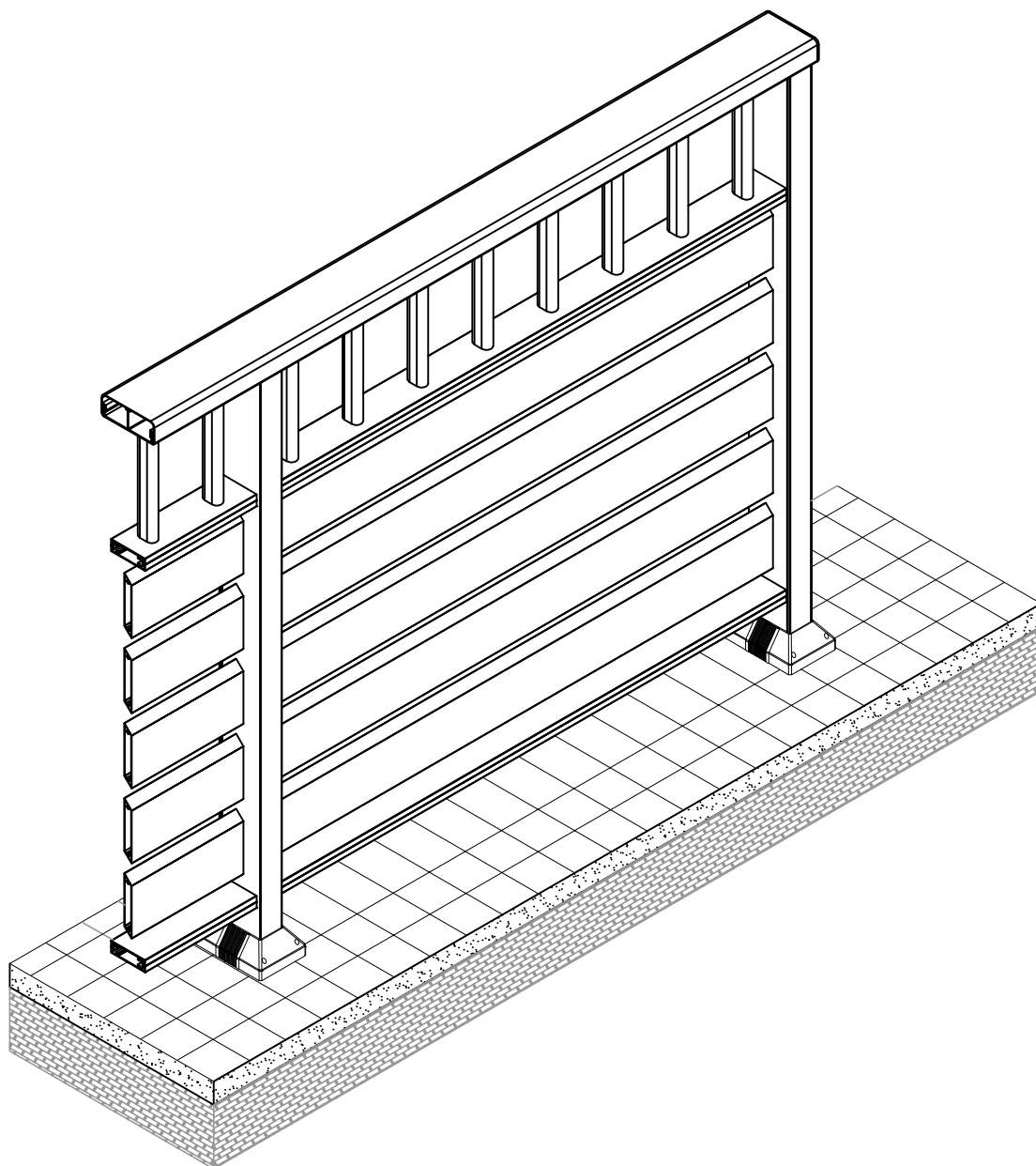



# Značajke sistema



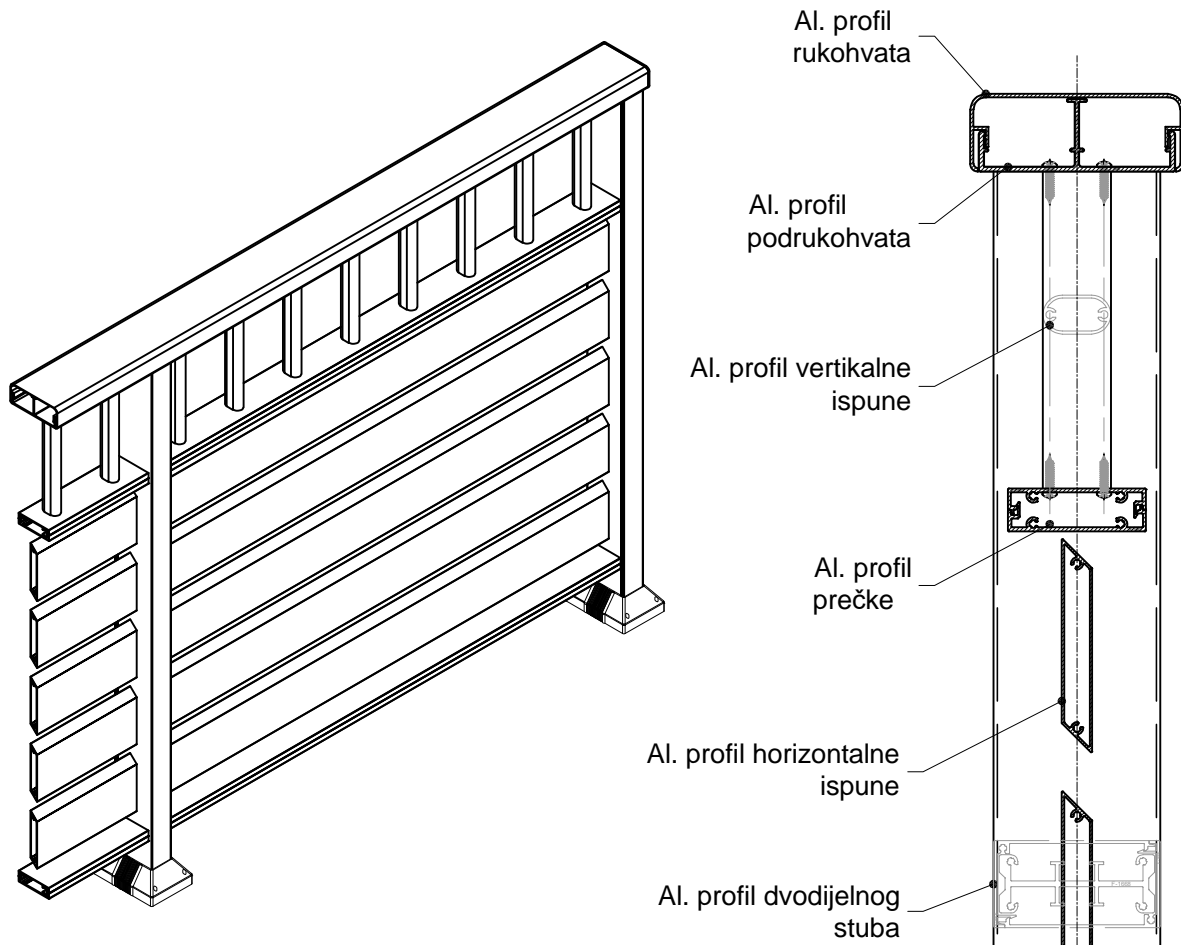

Stub 45x45

Stub 45x86

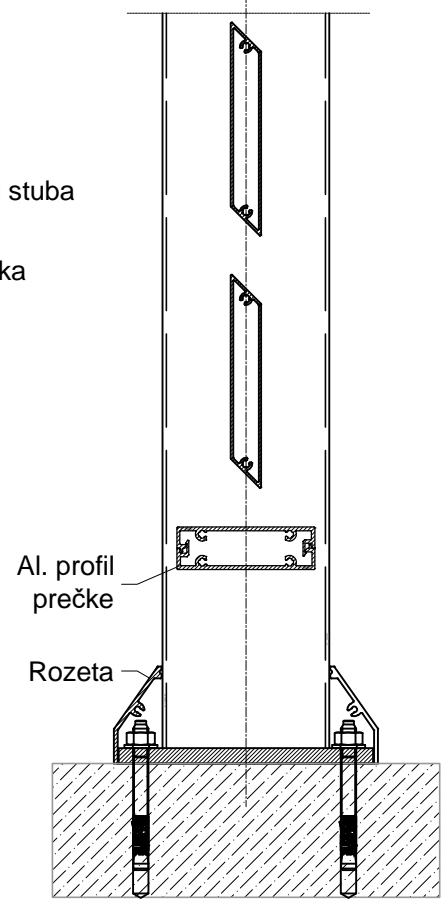
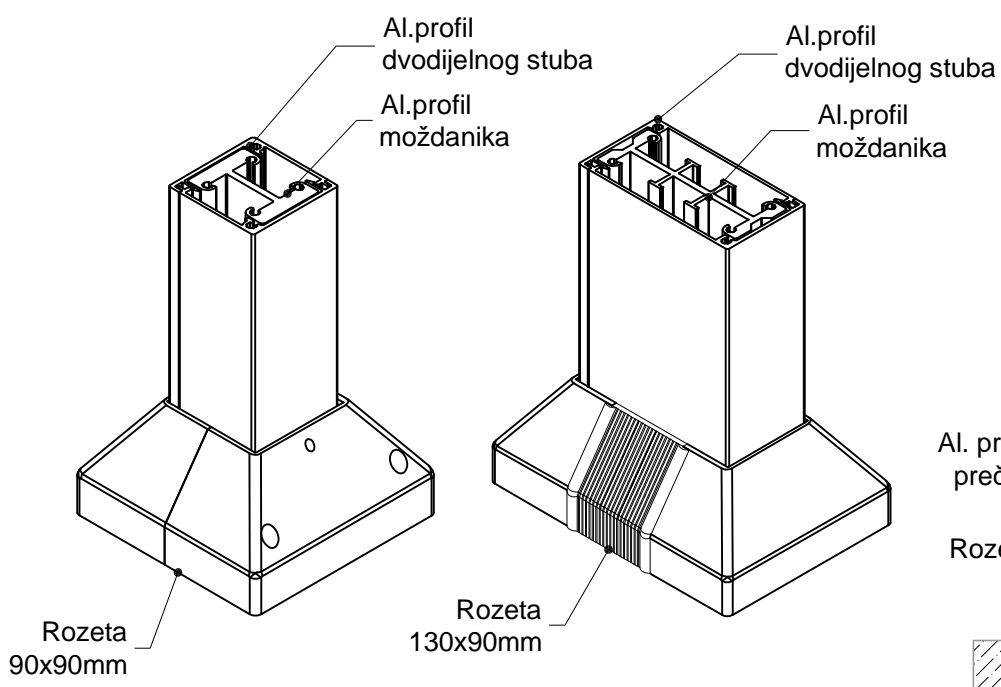

## OPIS SISTEMA OGRADA OF-80

Ograda OF-80 je inovativan sistem namjenjen brzom i jednostavnoj izradi i montaži balkonskih i dvorišnih ograda konstruiran od međusobno spojenih aluminijskih profila.

OF-80 odlikuje modularna izvedba, širok izbor lamela različitih dimenzija i oblika, visok stupanj sigurnosti i moderan izgled. Uz klasične fiksne ograde omogućena je izrada dvorišnih kliznih ili zaokretnih vrata .

Osnovna karakteristika sistema OF-80:

- spojevi profila bez dodatnih veznika koristeći samo vijčanu vezu i klipsanje profila.
- jednostavna zamjena profila ograde

Ogradni sistem OF-80 je namjenjen za ugradnju u različite vrste prostorija (balkoni, stubišta, terase, dvorane, dvorišta i sl). što ga čini idealnim rješenjem za hotele, tržne centre, javne objekte te moderne rezidencijalne objekte.

Zahvaljujući korištenju aluminijskog materijala OF-80 je otporan na vremenske i ostale utjecaje uključujući i uvjete u priobalnim područjima.

Aluminij kao materijal za ogradne sisteme nudi niz prednosti nad ostalim materijalima poput otpornosti na koroziju, čvrstoća, dugotrajnost i jednostavno održavanje.

OF-80 odlikuje:

- Dugotrajnost i otpornost prema vremenskim utjecajima
- Atraktivnost i raznovrsnost rješenja kroz široku ponudu lamela
- Brza i jednostavna montaža
- Mogućnost jednostavne demontaže
- Skriveni spojevi profila
- Praktičnost i lako održavanje
- Sigurnost zahvaljujući profilima dizajniranim u skladu sa zahtjevima europskih normi
- Široka paleta boja prema RAL karti zajedno s različitim vrstama eloksaže aluminijskih profila te imitacijama drveta ili kamena



## SADRŽAJ

01	ISPITIVANJA I CERTIFIKATI	<u>703.02.000</u>
02	PROFILI	<u>703.03.000</u>
03	VEZNI ELEMENTI	<u>703.04.000</u>
04	PVC ELEMENTI	<u>703.05.000</u>
05	MEHANIZMI	<u>703.06.000</u>
06	BRTVE	<u>703.07.000</u>
07	DODACI	<u>703.08.000</u>
08	PRESJECI	<u>703.09.000</u>
09	OBRADA I MONTAŽA	<u>703.10.000</u>

# Ispitivanja i certifikati



Tablični prikaz kategorija prostorija

Kategorija prostorije u zgradama EN 1991-1-1		Tablica 1.
Kategorija	Upotreba	Primjer
A	stambene prostorije	sobe u stambenim kućama i zgradama; sobe i odjeli u bolnicama; sobe u hotelima i pensionima; kuhinje i kupaonice
B	uredske prostorije	
C	prostorije gdje se mogu okupljati ljudi (osim prostorija određenih u kategorijama A, B, D i E)	<p>C1: prostorije sa stolovima i slično, npr. u školama, kavanama, restoranima, blagavaonicama, knjižnicama, recepcijama.</p> <p>C2: prostorije s nepomičnim stolicima, npr. u crkvama, kazalištima, kinima, sobe za sastanke, dvorane za predavanje, čekaonice i slično.</p> <p>C3: prostorije bez prepreka za kretanje ljudi, npr. u muzejima, izložbenim prostorima itd. te pristupi u javnim i administrativnim zgradama, hotelima i sl.</p> <p>C4: sportske prostorije i prostori za igru, npr. plesne dvorane, gimnastičke dvorane, pozornice i sl.</p> <p>C5: prostorije za velika okupljanja ljudi, npr. u zgradama za javne priredbe, kao što su koncertne dvorane, sportske dvorane, uključujući gledališta, terase, prilaze itd.</p>
D	prodajne prostorije	D1: prostorije u trgovinama D2: prostorije u robnim kućama i trgovinama naveliko, papirnicama i knjižarama itd.
E	prostorije s mogućnosti gomilanja robe i stvari i prilazi	skladišta, uključujući i knjižnice.

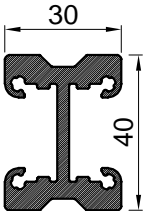
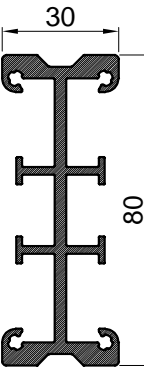
 <p><b>F-1665</b> lx=10.71</p>	Postignuta kategorija	 <p><b>F-1668</b> lx=51.27</p>	Postignuta kategorija
	A, B, C1(0,5 kN/m)		A, B, C1,C2,C3,C4,D(1,0 kN/m)
	-visina ograde do 1100mm razmak stubova do 1500mm		-visina ograde do 1100mm razmak stubova do 1500mm
	-visina ograde do 1500mm razmak stubova do 1000mm		-visina ograde do 1500mm razmak stubova do 1000mm

Dijagram dopuštenih dimenzija ograde za stub F-1665  
Diagram of allowed fence dimensions for pillar F-1665

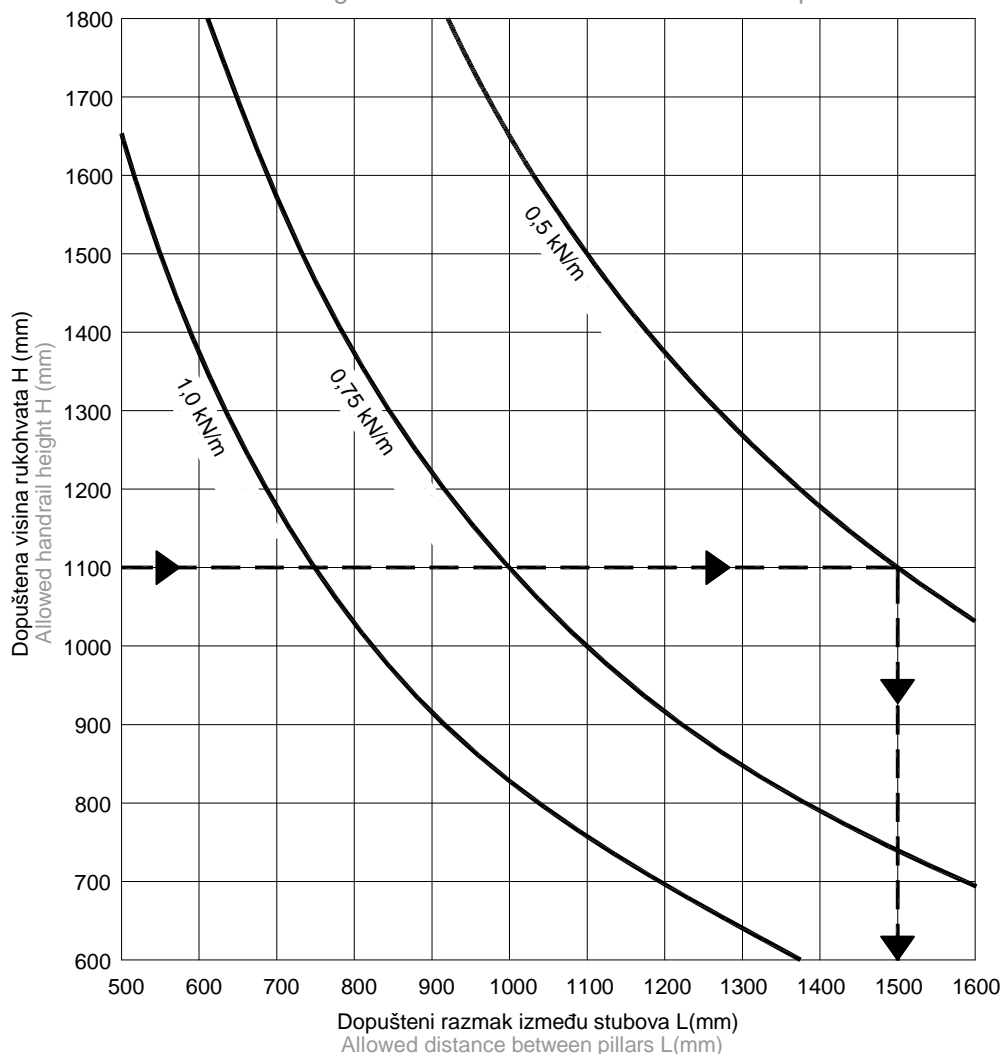

Primjer: Profil stuba: F-1665  
Visina rukohvata: 1100 mm  
Horizontalno opterećenje: 0,5 kN/m

Example: Pillar profile: F-1665  
Handrail height rukohvata: 1100 mm  
Horizontal load: 0,5 kN/m

Maksimalni razmak: 1500 mm

Maximal pillar distance: 1500 mm

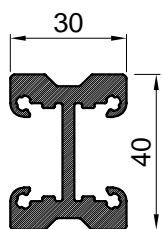

**F-1665**  
Ix=10.71

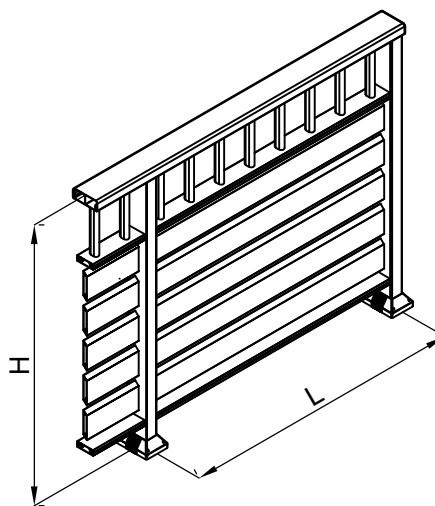
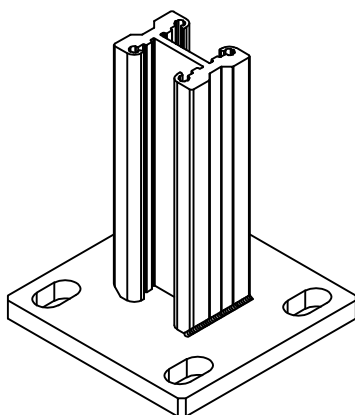

Dijagram dopuštenih dimenzija ograde za stub F-1668  
Diagram of allowed fence dimensions for pillar F-1668

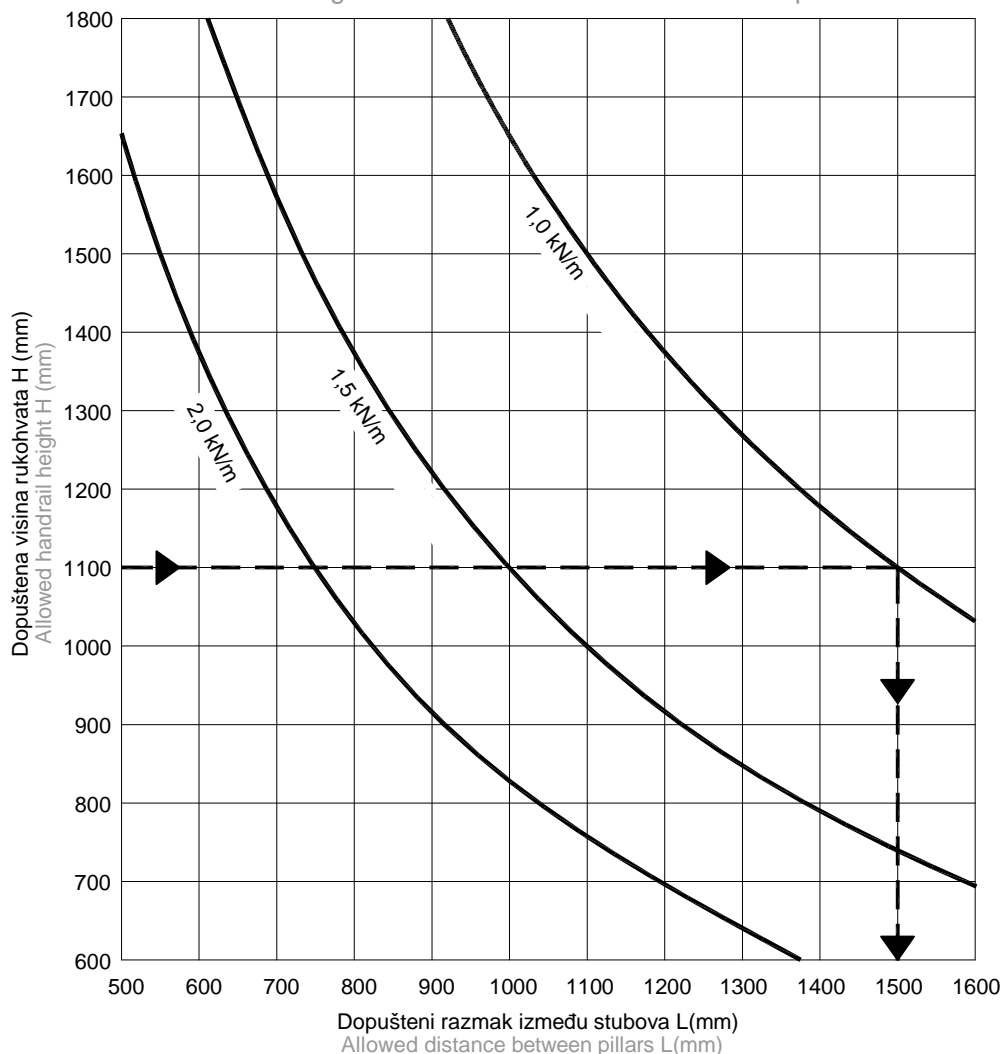

Primjer: Profil stuba: F-1668

Visina rukohvata: 1100 mm

Horizontalno opterećenje: 1,0 kN/m

Maksimalni razmak: 1500 mm

Example: Pillar profile: F-1668

Handrail height rukohvata: 1100 mm

Horizontal load: 1,0 kN/m

Maximal pillar distance: 1500 mm

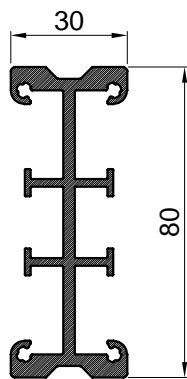

**F-1668**  
Ix=51.27

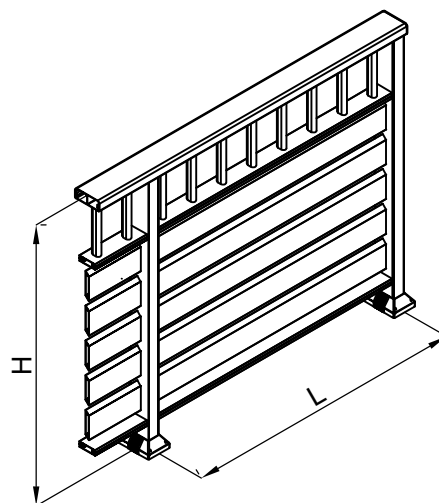
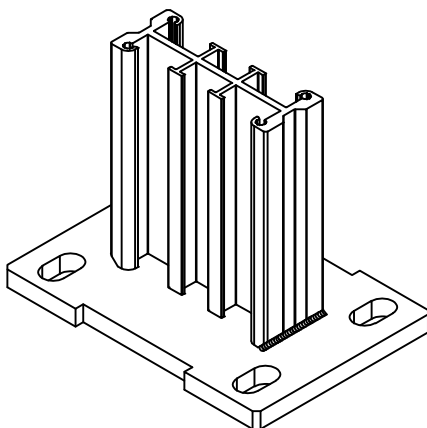



# Profili



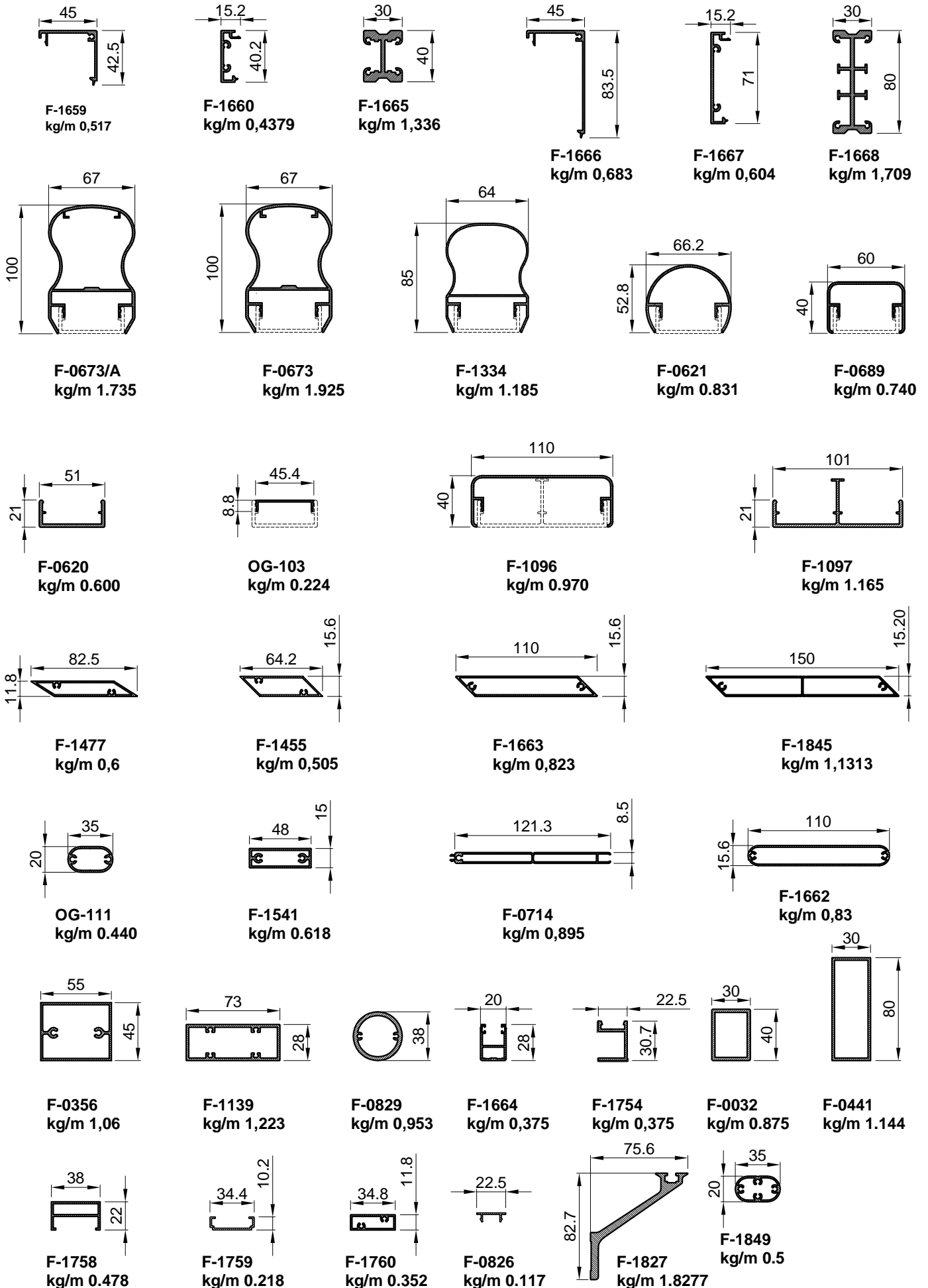



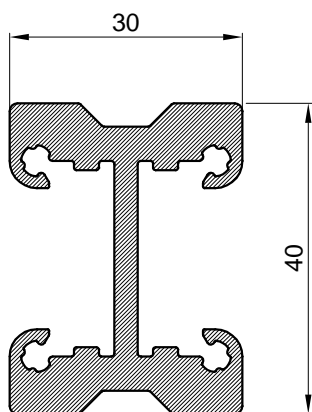

Profil moždanika		
Art.Br.	<b>F-1665</b>	
Težina	kg/m'	<b>1.336</b>
Opseg	mm	262.96
Moment inercije	$I_x$ (cm <sup>4</sup> )	10.71
	$I_y$ (cm <sup>4</sup> )	3.611
	$W_x$ (cm <sup>3</sup> )	5.35
	$W_y$ (cm <sup>3</sup> )	2.40
L	mm	6500

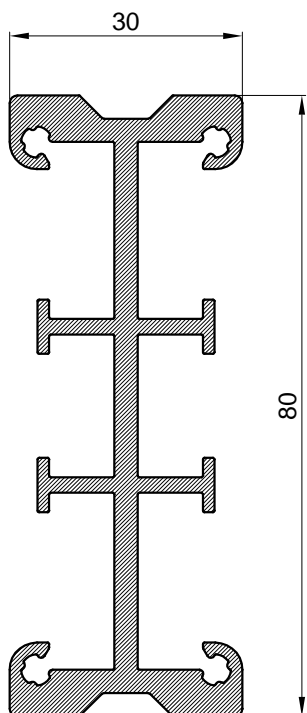

Profil moždanika		
Art.Br.	<b>F-1668</b>	
Težina	kg/m'	<b>1.709</b>
Opseg	mm	452.25
Moment inercije	$I_x$ (cm <sup>4</sup> )	51.27
	$I_y$ (cm <sup>4</sup> )	3.683
	$W_x$ (cm <sup>3</sup> )	12.81
	$W_y$ (cm <sup>3</sup> )	2.455
L	mm	6500

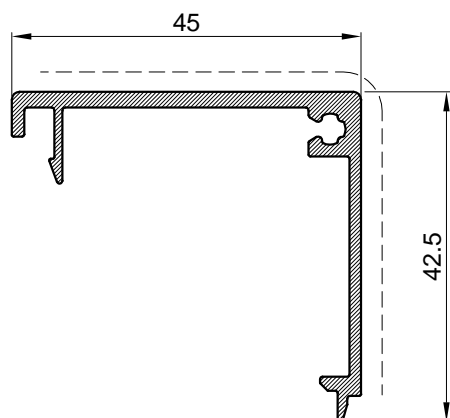

Profil stuba		
Art.Br.	<b>F-1659</b>	
Težina	kg/m'	<b>0.517</b>
Opseg	mm	216.31
Moment inercije	$I_x$ (cm <sup>4</sup> )	2.959
	$I_y$ (cm <sup>4</sup> )	4.64
	$W_x$ (cm <sup>3</sup> )	0.9003
	$W_y$ (cm <sup>3</sup> )	1.538
L	mm	6500

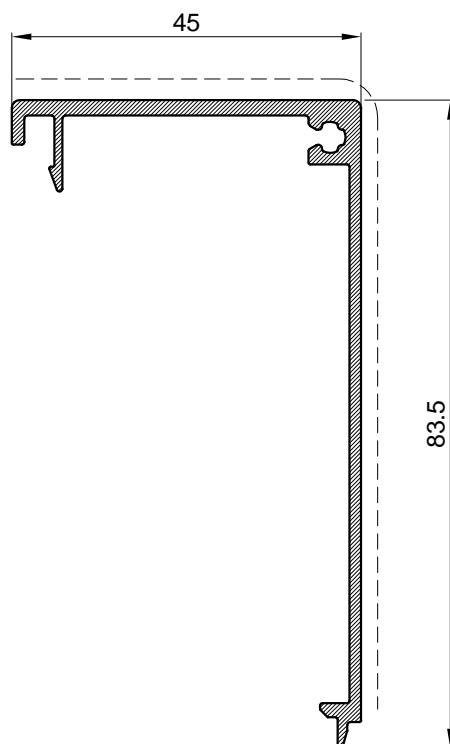

Profil stuba		
Art.Br.	<b>F-1666</b>	
Težina	kg/m'	<b>0.683</b>
Opseg	mm	298.31
Moment inercije	$I_x$ (cm <sup>4</sup> )	18.66
	$I_y$ (cm <sup>4</sup> )	5.56
	$W_x$ (cm <sup>3</sup> )	3.110
	$W_y$ (cm <sup>3</sup> )	1.656
L	mm	6500

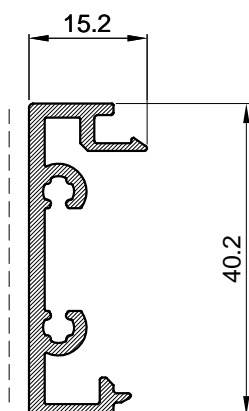

Profil prečke		
Art.Br.	<b>F-1660</b>	
Težina	kg/m'	<b>0.4379</b>
Opseg	mm	187.52
Moment inercije	$I_x$ (cm <sup>4</sup> )	0.209
	$I_y$ (cm <sup>4</sup> )	3.019
	$W_x$ (cm <sup>3</sup> )	0.186
	$W_y$ (cm <sup>3</sup> )	1.448
L	mm	<b>6500</b>

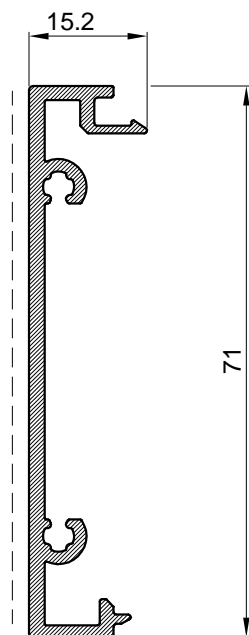

Profil prečke		
Art.Br.	<b>F-1667</b>	
Težina	kg/m'	<b>0.604</b>
Opseg	mm	248.88
Moment inercije	$I_x$ (cm <sup>4</sup> )	0.250
	$I_y$ (cm <sup>4</sup> )	13.306
	$W_x$ (cm <sup>3</sup> )	0.207
	$W_y$ (cm <sup>3</sup> )	3.632
L	mm	6500

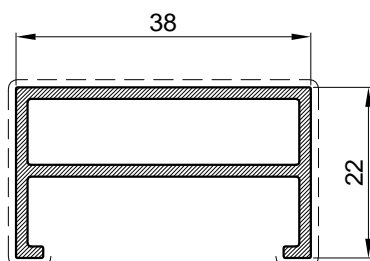

Profil okvira		
Art.Br.	<b>F-1758</b>	
Težina	kg/m'	<b>0.478</b>
Opseg	mm	147.6
Moment inercije	$I_x$ (cm <sup>4</sup> )	0.75
	$I_y$ (cm <sup>4</sup> )	3.44
	$W_x$ (cm <sup>3</sup> )	0.54
	$W_y$ (cm <sup>3</sup> )	1.81
L	mm	<b>6500</b>

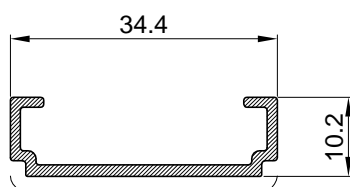

Držlač ispune		
Art.Br.	<b>F-1759</b>	
Težina	kg/m'	<b>0.218</b>
Opseg	mm	115
Moment inercije	$I_x$ (cm <sup>4</sup> )	0.09
	$I_y$ (cm <sup>4</sup> )	1.23
	$W_x$ (cm <sup>3</sup> )	0.13
	$W_y$ (cm <sup>3</sup> )	0.72
L	mm	6500

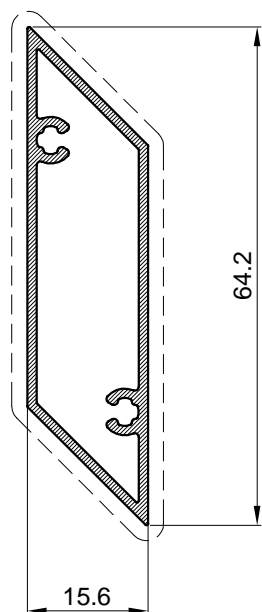

Profil ispune		
Art.Br.	<b>F-1455</b>	
Težina	kg/m'	<b>0.505</b>
Opseg	mm	141.42
Moment inercije	$I_x$ (cm <sup>4</sup> )	4.40
	$I_y$ (cm <sup>4</sup> )	2.65
	$W_x$ (cm <sup>3</sup> )	1.58
	$W_y$ (cm <sup>3</sup> )	1.52
L	mm	6500

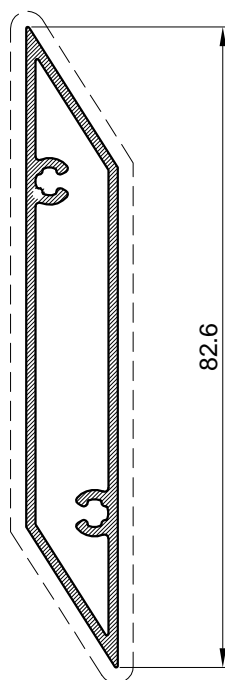

Profil ispune		
Art.Br.	<b>F-1477</b>	
Težina	kg/m'	<b>0.600</b>
Opseg	mm	179.19
Moment inercije	$I_x$ (cm <sup>4</sup> )	0.492
	$I_y$ (cm <sup>4</sup> )	11.89
	$W_x$ (cm <sup>3</sup> )	0.835
	$W_y$ (cm <sup>3</sup> )	2.88
L	mm	6500

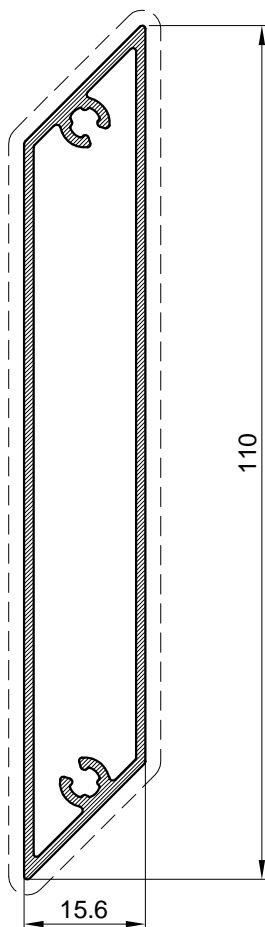

Profil ispunje		
Art.Br.	<b>F-1663</b>	
Težina	kg/m'	<b>0.826</b>
Opseg	mm	233
Moment inercije	$I_x$ (cm <sup>4</sup> )	34.40
	$I_y$ (cm <sup>4</sup> )	1.266
	$W_x$ (cm <sup>3</sup> )	6.255
	$W_y$ (cm <sup>3</sup> )	1.62
L	mm	6500

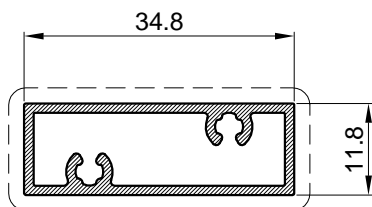

Profil ispunje		
Art.Br.	<b>F-1760</b>	
Težina	kg/m'	<b>0.352</b>
Opseg	mm	93
Moment inercije	$I_x$ (cm <sup>4</sup> )	0.27
	$I_y$ (cm <sup>4</sup> )	1.69
	$W_x$ (cm <sup>3</sup> )	0.47
	$W_y$ (cm <sup>3</sup> )	0.97
L	mm	6500

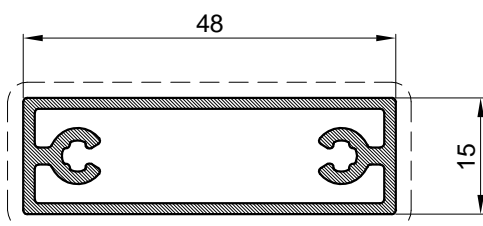
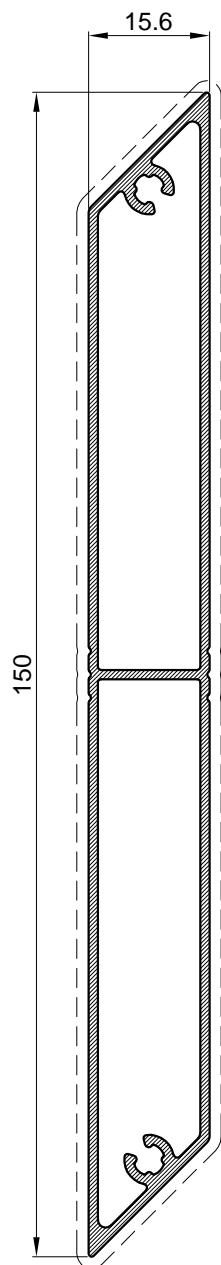

Profil		
Art.-Br.	<b>F-1845</b>	
Težina	kg/m	<b>1.1313</b>
Opseg	mm	314.32
Moment inercije	I <sub>x</sub> (cm <sup>4</sup> )	85.28
	I <sub>y</sub> (cm <sup>4</sup> )	1.79
	W <sub>x</sub> (cm <sup>4</sup> )	11.37
	W <sub>y</sub> (cm <sup>4</sup> )	2.29
Dužina isporuke	mm	6500

Profil		
Art.Br.	<b>F-1541</b>	
Težina	kg/m	<b>0.618</b>
Opseg	mm	186
Moment inercije	I <sub>x</sub> (cm <sup>4</sup> )	6.49
	I <sub>y</sub> (cm <sup>4</sup> )	0.69
	W <sub>x</sub> (cm <sup>4</sup> )	2.70
	W <sub>y</sub> (cm <sup>4</sup> )	0.92
L	mm	6500

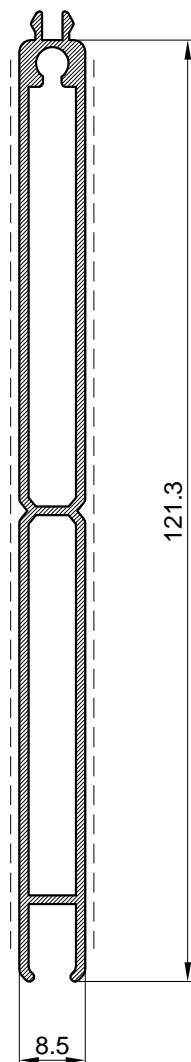

Profil ispune		
Art.Br.	<b>F-0714</b>	
Težina	kg/m'	<b>0.895</b>
Opseg	mm	294.19
Moment inercije	$I_x$ (cm <sup>4</sup> )	46.51
	$I_y$ (cm <sup>4</sup> )	0.4
	$W_x$ (cm <sup>3</sup> )	7.22
	$W_y$ (cm <sup>3</sup> )	0.95
L	mm	6500

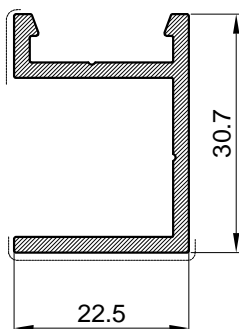

Držać ispune		
Art.Br.	<b>F-1754</b>	
Težina	kg/m'	<b>0.43</b>
Opseg	mm	161.22
Moment inercije	$I_x$ (cm <sup>4</sup> )	1.84
	$I_y$ (cm <sup>4</sup> )	0.98
	$W_x$ (cm <sup>3</sup> )	1.19
	$W_y$ (cm <sup>3</sup> )	0.71
L	mm	6500

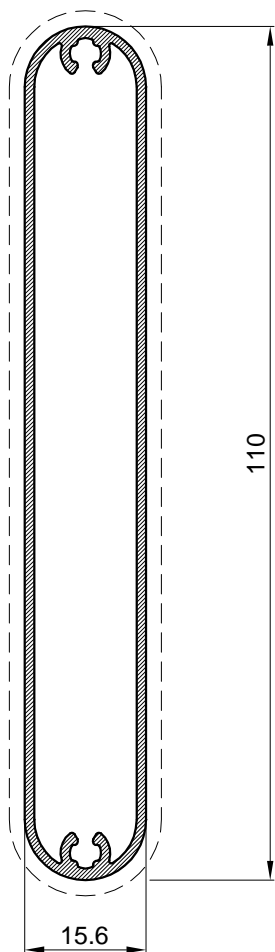

Profil ispune		
Art.Br.	<b>F-1662</b>	
Težina	kg/m'	<b>0.834</b>
Opseg	mm	237.81
Moment inercije	I <sub>x</sub> (cm <sup>4</sup> )	38.93
	I <sub>y</sub> (cm <sup>4</sup> )	3.019
	W <sub>x</sub> (cm <sup>3</sup> )	0.186
	W <sub>y</sub> (cm <sup>3</sup> )	1.448
L	mm	6500

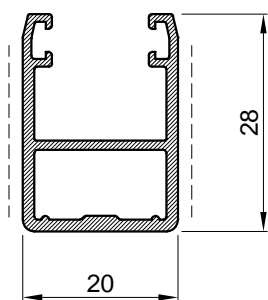

Držać ispune		
Art.Br.	<b>F-1664</b>	
Težina	kg/m'	<b>0.375</b>
Opseg	mm	149.50
Moment inercije	I <sub>x</sub> (cm <sup>4</sup> )	1.029
	I <sub>y</sub> (cm <sup>4</sup> )	0.848
	W <sub>x</sub> (cm <sup>3</sup> )	0.622
	W <sub>y</sub> (cm <sup>3</sup> )	0.848
L	mm	6500

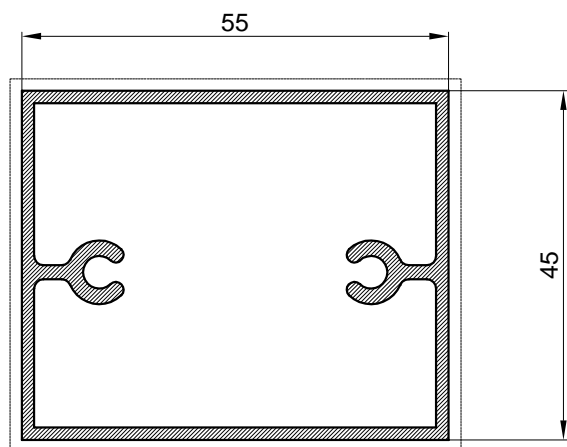

Profil ispune		
Art.Br.	<b>F-0356</b>	
Težina	kg/m'	<b>1.06</b>
Opseg	mm	200
Moment inercije	I <sub>x</sub> (cm <sup>4</sup> )	10.28
	I <sub>y</sub> (cm <sup>4</sup> )	17.09
	W <sub>x</sub> (cm <sup>3</sup> )	4.53
	W <sub>y</sub> (cm <sup>3</sup> )	6.21
L	mm	6500

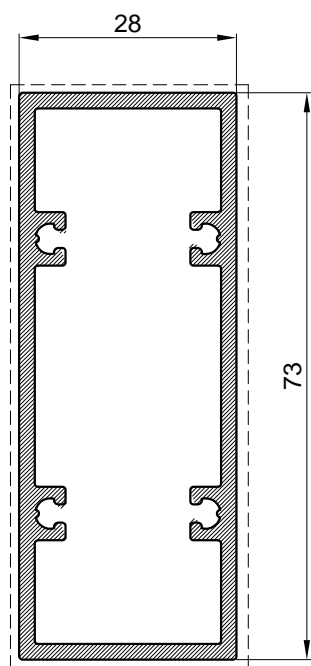

Profil ispune		
Art.Br.	<b>F-1139</b>	
Težina	kg/m'	<b>1.223</b>
Opseg	mm	201.31
Moment inercije	I <sub>x</sub> (cm <sup>4</sup> )	6.07
	I <sub>y</sub> (cm <sup>4</sup> )	27.13
	W <sub>x</sub> (cm <sup>3</sup> )	4.33
	W <sub>y</sub> (cm <sup>3</sup> )	7.43
L	mm	6500

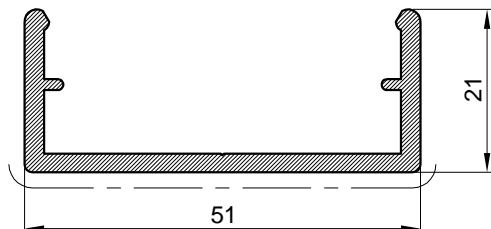

Profil		
Art.-Br.	<b>F-0620</b>	
Težina	kg/m	<b>0.600</b>
Opseg	mm	188
Moment inercije	$I_x$ (cm <sup>4</sup> )	0.88
	$I_y$ (cm <sup>4</sup> )	8.43
	$W_x$ (cm <sup>4</sup> )	0.58
	$W_y$ (cm <sup>4</sup> )	3.31
L	mm	6500

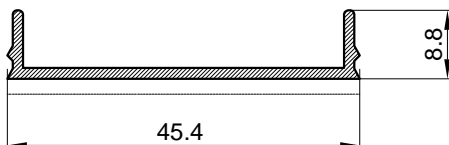

Profil		
Art.-Br.	<b>OG-103</b>	
Težina	kg/m	<b>0.224</b>
Opseg	mm	122
Moment inercije	$I_x$ (cm <sup>4</sup> )	0.04
	$I_y$ (cm <sup>4</sup> )	1.97
	$W_x$ (cm <sup>4</sup> )	0.05
	$W_y$ (cm <sup>4</sup> )	0.87
L	mm	6500

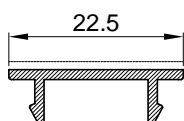

Profil		
Art.Br.	<b>F-0826</b>	
Težina	kg/m'	<b>0.117</b>
Opseg	mm	70.3
L	mm	6500

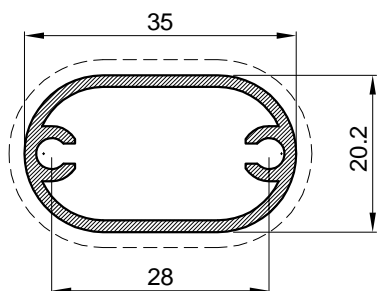

Profil		
Art.-Br.	<b>OG-111</b>	
Težina	kg/m	<b>0.44</b>
Opseg	mm	93
Moment inercije	$I_x$ (cm <sup>4</sup> )	0.78
	$I_y$ (cm <sup>4</sup> )	2.28
	$W_x$ (cm <sup>4</sup> )	0.78
	$W_y$ (cm <sup>4</sup> )	1.30
L	mm	6500

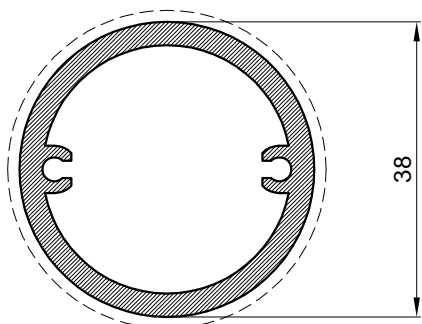

Profil		
Art.Br.	<b>F-0829</b>	
Težina	kg/m'	0.953
Opseg	mm	119
L	mm	6500

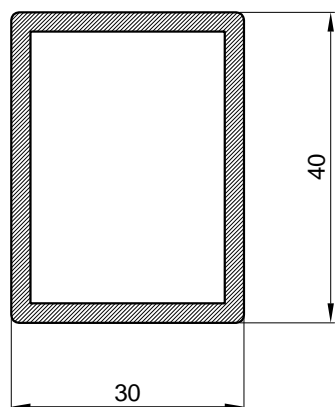

Profil		
Art.Br.	<b>F-0032</b>	
Težina	kg/m'	<b>0.875</b>
Opseg	mm	138.28
L	mm	6500

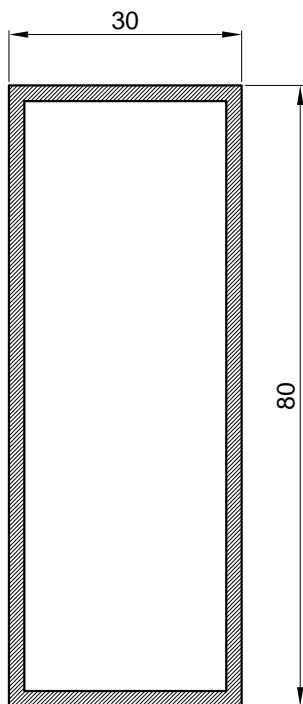

Profil		
Art.-Br.	<b>F-0441</b>	
Težina	kg/m	<b>1.144</b>
Opseg	mm	220
Moment inercije	$I_x$ (cm <sup>4</sup> )	6.87
	$I_y$ (cm <sup>4</sup> )	32.88
	$W_x$ (cm <sup>4</sup> )	4.58
	$W_y$ (cm <sup>4</sup> )	8.22
L	mm	6500

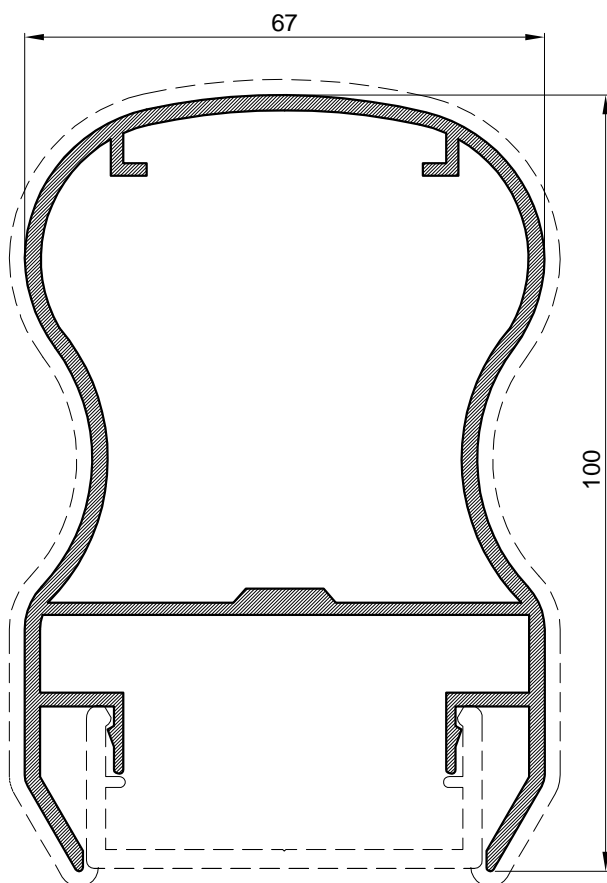

Profil rukohvata		
Art.-Br.	<b>F-0673</b>	
Težina	kg/m	<b>1.925</b>
Opseg	mm	469
Moment inercije	$I_x$ (cm <sup>4</sup> )	66.23
	$I_y$ (cm <sup>4</sup> )	44.90
	$W_x$ (cm <sup>4</sup> )	12.74
	$W_y$ (cm <sup>4</sup> )	13.39
L	mm	6500

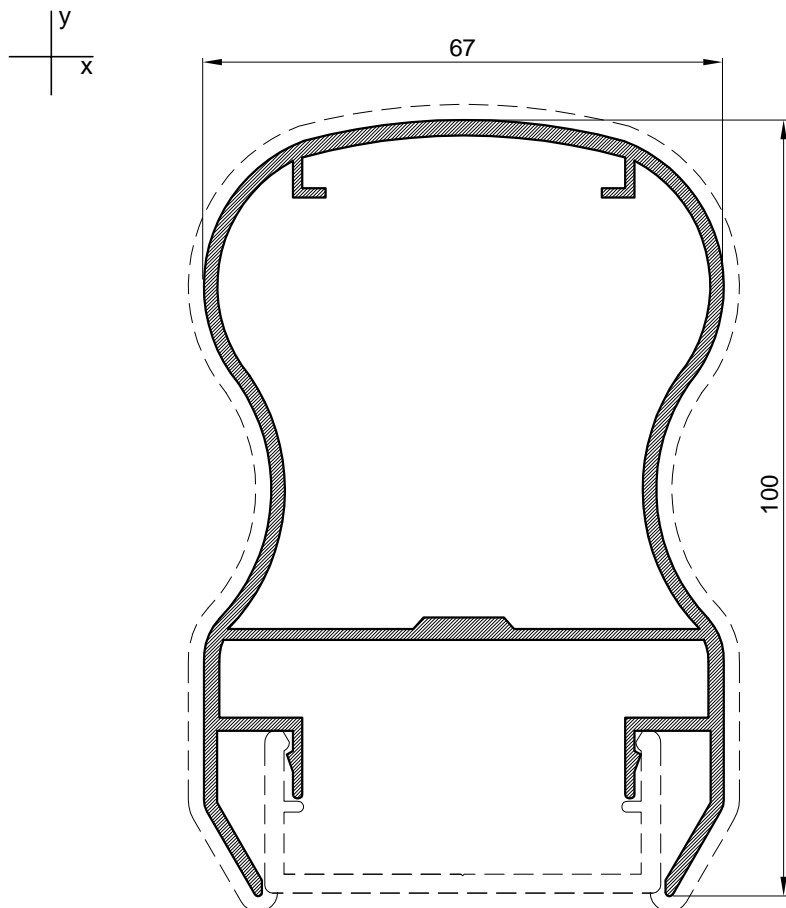

Profil rukohvata		
Art.-Br.	<b>F-0673/A</b>	
Težina	kg/m	<b>1.735</b>
Opseg	mm	470
Moment inercije	$I_x$ (cm <sup>4</sup> )	60.76
	$I_y$ (cm <sup>4</sup> )	40.48
	$W_x$ (cm <sup>4</sup> )	11.66
	$W_y$ (cm <sup>4</sup> )	12.08
	mm	6500

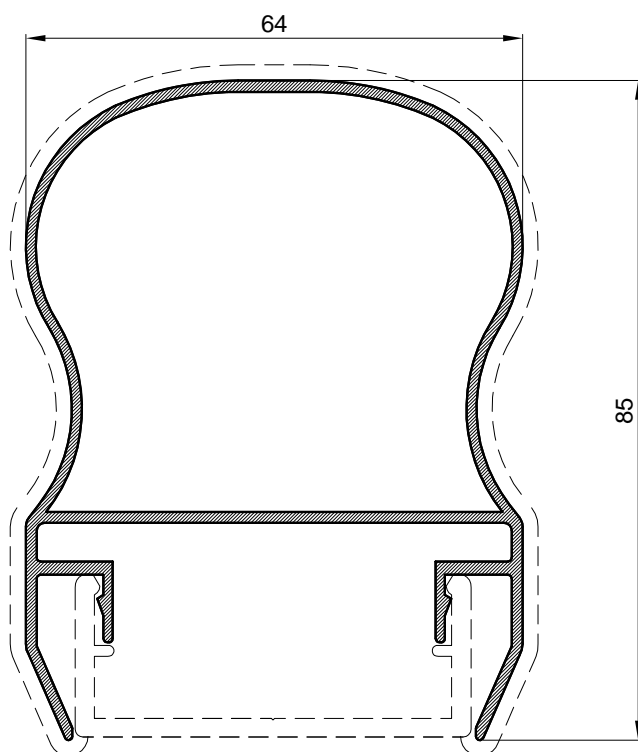

Profil rukohvata		
Art.-Br.	<b>F-1334</b>	
Težina	kg/m	<b>1.185</b>
Opseg	mm	414.53
Moment inercije	$I_x$ (cm <sup>4</sup> )	28.66
	$I_y$ (cm <sup>4</sup> )	26.24
	$W_x$ (cm <sup>4</sup> )	6.70
	$W_y$ (cm <sup>4</sup> )	8.20
	mm	6500

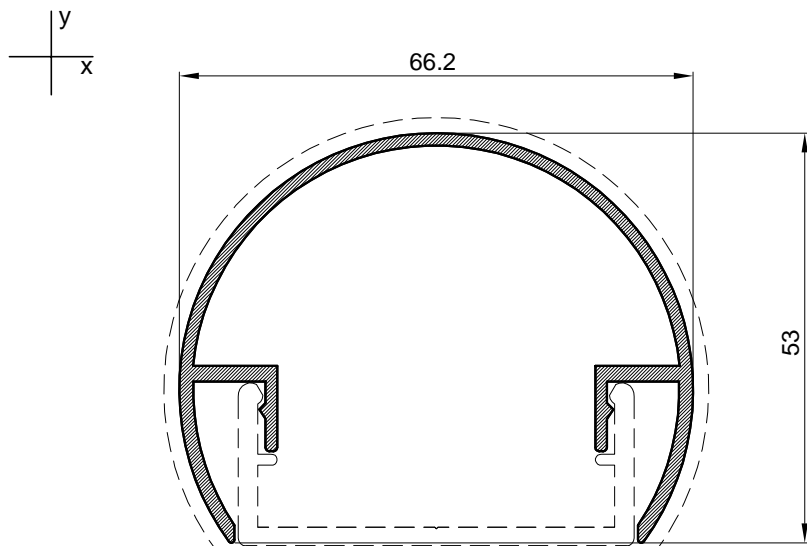

Profil rukohvata		
Art.-Br.	<b>F-0621</b>	
Težina	kg/m	<b>0.831</b>
Opseg	mm	367
Moment inercije	I <sub>x</sub> (cm <sup>4</sup> )	7.21
	I <sub>y</sub> (cm <sup>4</sup> )	19.42
	W <sub>x</sub> (cm <sup>4</sup> )	2.55
	W <sub>y</sub> (cm <sup>4</sup> )	5.87
L	mm	6500

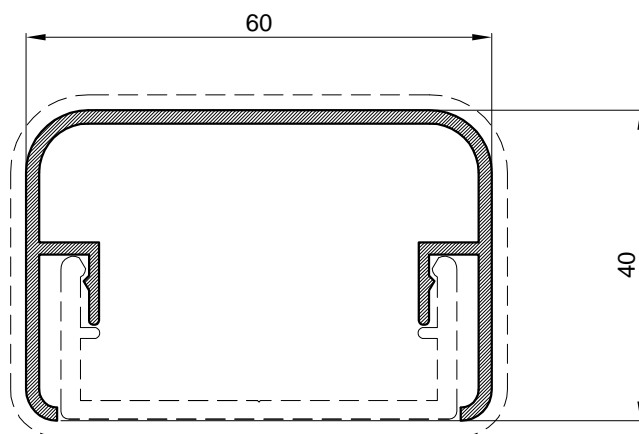

Profil rukohvata		
Art.-Br.	<b>F-0689</b>	
Težina	kg/m	<b>0.74</b>
Opseg	mm	335
Moment inercije	I <sub>x</sub> (cm <sup>4</sup> )	4.20
	I <sub>y</sub> (cm <sup>4</sup> )	15.94
	W <sub>x</sub> (cm <sup>4</sup> )	1.64
	W <sub>y</sub> (cm <sup>4</sup> )	5.31
L	mm	6500

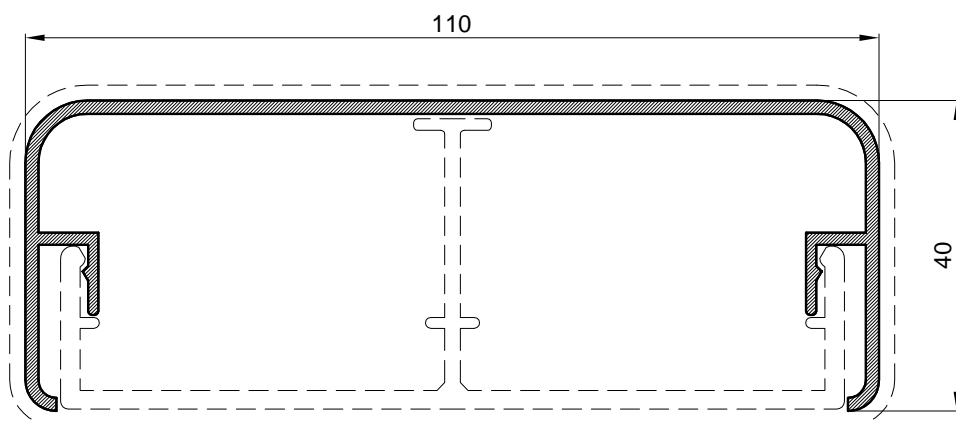

Profil rukohvata		
Art.-Br.	<b>F-1096</b>	
Težina	kg/m	<b>0.970</b>
Opseg	mm	435
Moment inercije	I <sub>x</sub> (cm <sup>4</sup> )	5.37
	I <sub>y</sub> (cm <sup>4</sup> )	65.89
	W <sub>x</sub> (cm <sup>4</sup> )	1.86
	W <sub>y</sub> (cm <sup>4</sup> )	11.98
L	mm	6500

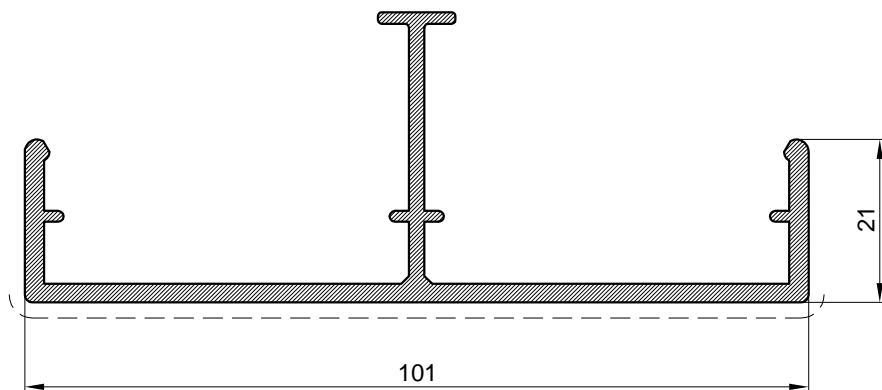

Profil		
Art.-Br.	<b>F-1097</b>	
Težina	kg/m	<b>1.165</b>
Opseg	mm	372
Moment inercije	$I_x$ (cm <sup>4</sup> )	4.21
	$I_y$ (cm <sup>4</sup> )	44.62
	$W_x$ (cm <sup>4</sup> )	1.42
	$W_y$ (cm <sup>4</sup> )	8.83
L	mm	6500

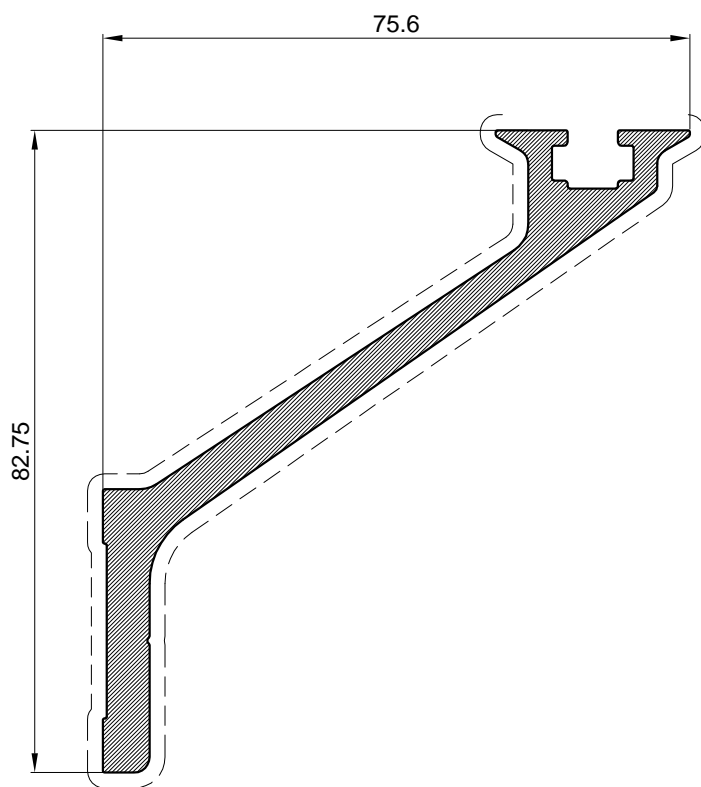

Profil		
Art.-Br.	<b>F-1827</b>	
Težina	kg/m	<b>1.8277</b>
Opseg	mm	287.16
Moment inercije	$I_x$ (cm <sup>4</sup> )	36.21
	$I_y$ (cm <sup>4</sup> )	38.89
	$W_x$ (cm <sup>4</sup> )	7.87
	$W_y$ (cm <sup>4</sup> )	8.41
L	mm	6500

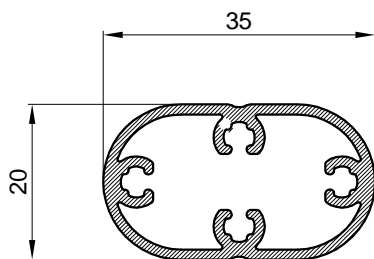

Profil		
Art.-Br.	<b>F-1849</b>	
Težina	kg/m	<b>0.5</b>
Opseg	mm	93.1
Moment inercije	I <sub>x</sub> (cm <sup>4</sup> )	0.83
	I <sub>y</sub> (cm <sup>4</sup> )	2.22
	W <sub>x</sub> (cm <sup>4</sup> )	0.83
	W <sub>y</sub> (cm <sup>4</sup> )	1.27
L	mm	6500



# Vezni elementi

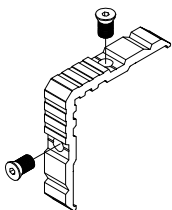
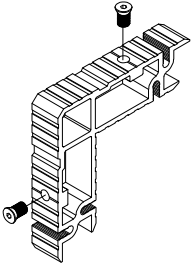
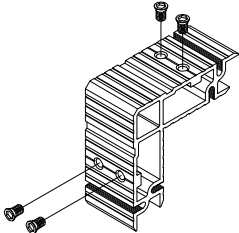
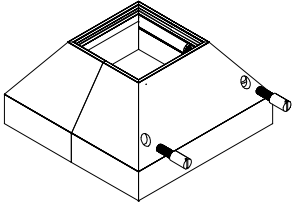
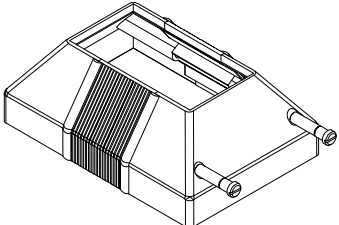
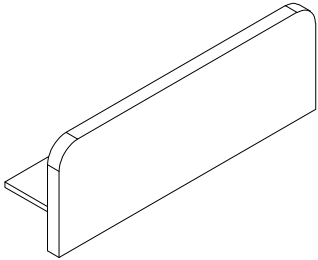

Oznaka	Izgled-presjek	Opis	Materijal	Napomena
725.213		-Kutna spojnica za komoru 17x8.5 -Za profile: F-1664 -Stara oznaka: 725.206	Al	
710.073		-Kutna spojnica za komoru 35x25 -Za profile: F-0032	Al	
710.544		-Kutna spojnica za komoru 76x26 -Za profile: F-0441	Al	
392.001.01 02 03		- Maska stuba al. ograde (45x45) - Oznaka proizvođača 700.300.310 700.300.305 ; 700.300.313 - Boje: 01- bijela; 02 - siva;03 - crna	Zamak	
392.002.01 02 03		- Maska stuba al. ograde (45x86) - Boje: 01- bijela; 02 - siva;03 - crna	Al.+Zamk 5	
391.204.01 02 03		Al.poklopac za rukohvat F-1096	Al	

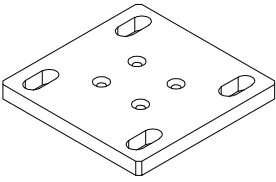
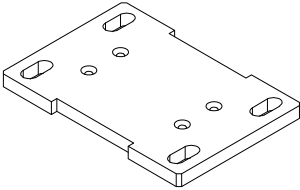
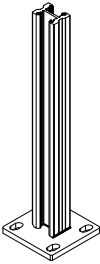
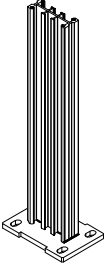
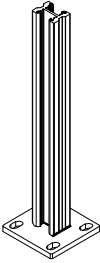
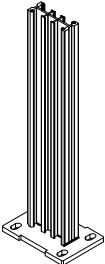
Oznaka	Izgled-presjek	Opis	Materijal	Napomena
521.320		-Ploča stuba (F-1665) 90x90	Al	
521.321		-Ploča stuba (F-1668) 90x130	Al	
521.322		-Set za visinu ograde 1100mm -Za stub 45x45 -Ploča 90x90	Al	
521.323		-Set za visinu ograde 1100mm -Za stub 45x86 -Ploča 90x130	Al	
521.324		-Set za visinu ograde 1500mm -Za stub 45x45 -Ploča 90x90	Al	
521.325		-Set za visinu ograde 1500mm -Za stub 45x86 -Ploča 90x130	Al	

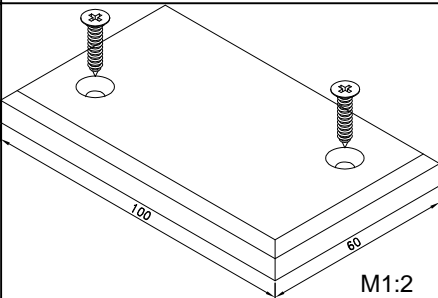
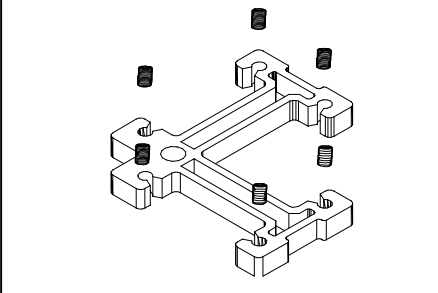
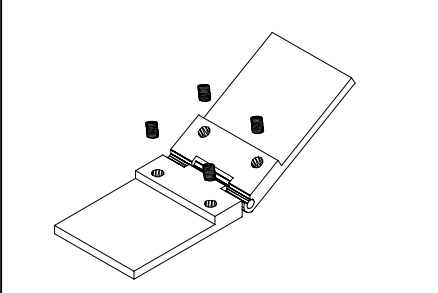
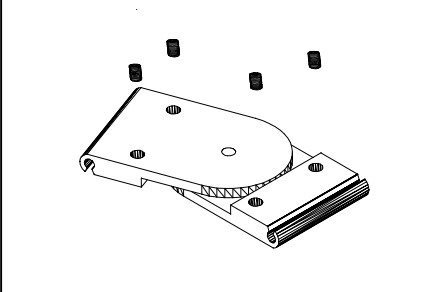
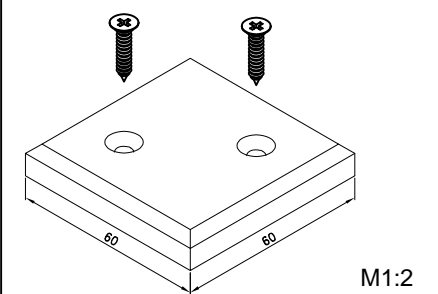
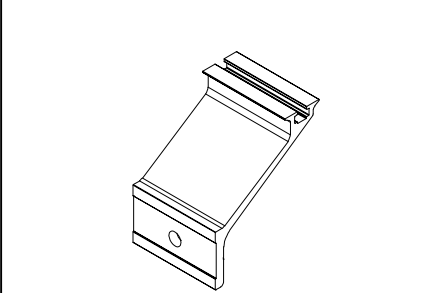
Oznaka	Izgled-presjek	Opis	Materijal	Napomena
391.206.01 .02 .03		Al.čep za moždanik F-1668 (30x80) Ograda OF-80	Al.	
521.049		- Kutna spojnica za komoru 8x47 - Za profile: F-1097 F-0620	Al.	
521.050		- Veznik pod kutem za komoru 8x47 -Za profile: F-1097 F-0620	Al	
521.051		- Veznik pod kutem; za komoru 8x47 - Za profile: F-1097 F-0620	Al	
391.239		Al.čep za moždanik F-1665 (30x40) Ograda OF-80	Al.	
521.512.01 .02 .03		- držač profila podrukohvata - radi se iz profila F-1827 - koristi se vijak-tipla	Al.	

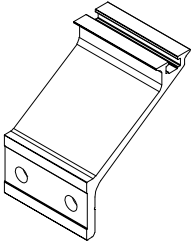
Oznaka	Izgled-presjek	Opis	Materijal	Napomena
521.513.01 .02 .03		<ul style="list-style-type: none"><li>- držač profila podrukohvata</li><li>- radi se iz profila F-1827</li><li>- koristi se vijak-tipla</li></ul>	Al.	

# PVC elementi



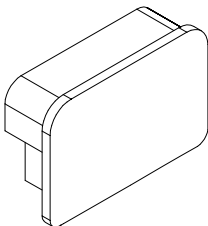
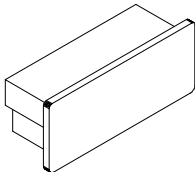
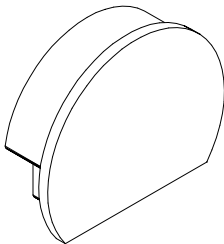
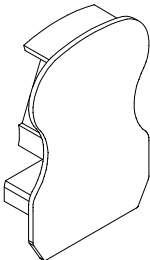
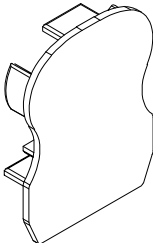
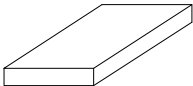

Oznaka	Izgled-presjek	Opis	Materijal	Napomena
373.007.01 02 03		- Bočni čep za profil F-0689 - Stara oznaka: RA 450 01-bijela 02-siva 03-crna	PVC	
373.008.01 02 03		- Bočni čep za profil F-0620 - Stara oznaka: RA 452 01-bijela 02-siva 03-crna	PVC	
374.036.01 02 03		- Bočni čep za profil F-0621 - Stara oznaka: RA 723 01-bijela 02-siva 03-crna	PVC	
373.009.01 02 03		- Bočni čep za profil F-0673 - Stara oznaka: RA 752 - 01-bijela 02-siva 03-crna	PVC	
373.030.01 02 03		- Bočni čep za profil F-1334 01-bijela 02-siva 03-crna	PVC	
370.034		- Podmetači za staklo 100 x 30 x 6 mm - Kod proizvođača BO51230 06	PVC	



# Mehanizmi

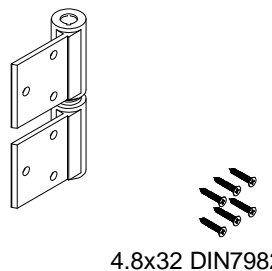
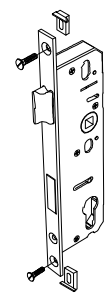

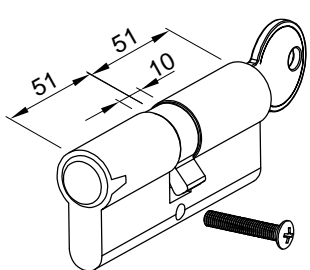
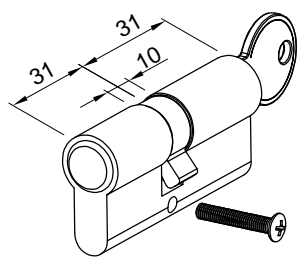
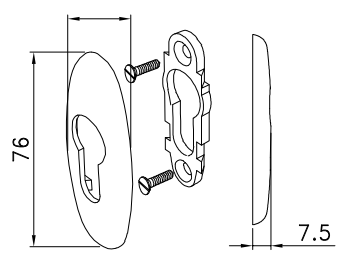
Oznaka	Izgled-presjek	Opis	Materijal	Napomena
111.027.01 02 03	 <p>4.8x32 DIN7982</p>	<ul style="list-style-type: none"> <li>-Dvodijelna šarka za vrata</li> <li>-Stub 45x86</li> <li>-Stub 45x45</li> <li>Boje: 01- bijela; 02 - siva;03 - crna</li> </ul>	Al+PVC	
124.016		<ul style="list-style-type: none"> <li>- Brava 25 mm sa jezičkom</li> <li>- Stara oznaka: 3020.00</li> </ul>	Inox Čelik	
121.006		- Prihvatnik brave	Al	
124.040		<ul style="list-style-type: none"> <li>- Uložak za bravu 51x51 (45x86)</li> <li>- Oznaka proizvođača: 5062.00.520</li> </ul>	Nikal	
124.025		<ul style="list-style-type: none"> <li>- Uložak za bravu 31x31 (45x45)</li> <li>- Oznaka proizvođača: 5052.00.520</li> </ul>	Nikal	
124.032.01 02 03		<ul style="list-style-type: none"> <li>- Štitnik cilindra za bravu (par)</li> <li>- Stara oznaka: 1031.04 (Stublina)</li> <li>- Boje: 01- bijela; 02 - siva;03 - crna</li> </ul>	Zn Čelik	

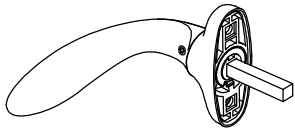
Oznaka	Izgled-presjek	Opis	Materijal	Napomena
<b>104.001.01</b> <b>02</b> <b>03</b>		<ul style="list-style-type: none"> <li>- Ručke za vrata (par)</li> <li>- Stara oznaka: 1032.00</li> <li>- Boje: 01- bijela; 02 - siva;03 - crna</li> </ul>	AISi Zamak	

Brtve



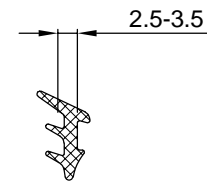
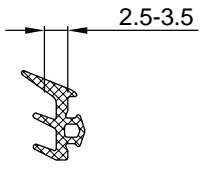
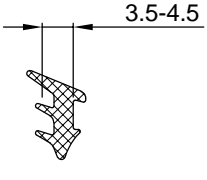
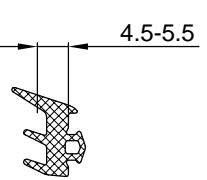





Oznaka	Izgled-presjek	Opis	Materijal	Napomena
311.001		-Brtva prema staklu /unutarnja/ -Stara oznaka 210.001.125 (921)	EPDM	
321.002		-Brtva prema staklu /vanjska/ -Stara oznaka - (Z111)	EPDM	
311.002		-Brtva prema staklu /unutarnja/ -Stara oznaka 210.001.123 (918)	EPDM	
321.003		-Brtva prema staklu /vanjska/ -Stara oznaka - (Z113)	EPDM	

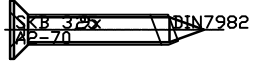

# Dodaci

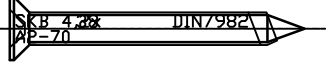

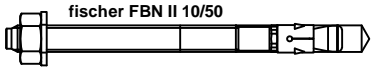
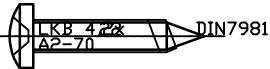
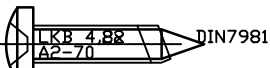
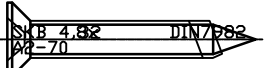
Oznaka	Izgled-presjek	Opis	Materijal	Napomena
433.006	 SKB 3.5x22 A2-70 DIN7981	Vijak 3.5x22 DIN 7981	Inox A2	
433.104	 SKB 3.9x13 A2-70 DIN7982	Vijak 3.9x13 DIN 7982	Inox A2	
433.016	 SKB 3.9x13 A2-70 DIN7981	Vijak 3.9x13 DIN 7981	Inox A2	
433.108	 SKB 3.9x22 A2-70 DIN7982	Vijak 3.9x22 DIN 7982		
433.019	 SKB 3.9x22 A2-70 DIN7981	Vijak 3.9x22 DIN 7981	Inox A2	
433.122	 SKB 4.2x38 A2-70 DIN7982	Vijak 4.2x38 DIN 7982	Inox A2	

Oznaka	Izgled-presjek	Opis	Materijal	Napomena
430.014		Anker čelični Fischer FBN 2 10/50		
433.031		Vijak 4.2x22 DIN 7981	Inox A2	
433.044		Vijak 4.8x22 DIN 7981	Inox A2	
433.133		Vijak 4.8x32 DIN 7982	Inox A2	
230.028		Šablon za stub ograde OF-80	Al+Inox	

# Sheme

Tip: A-86

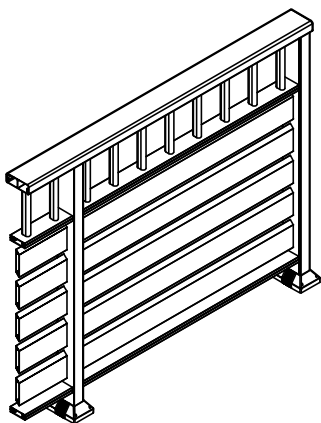

Tip: B-86

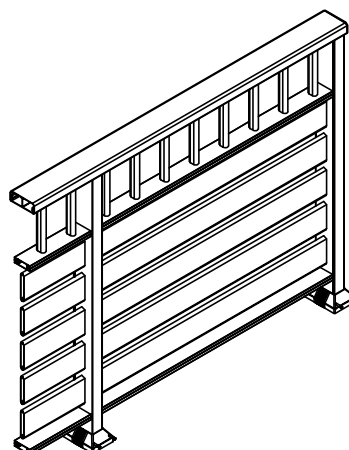

Tip: C-86

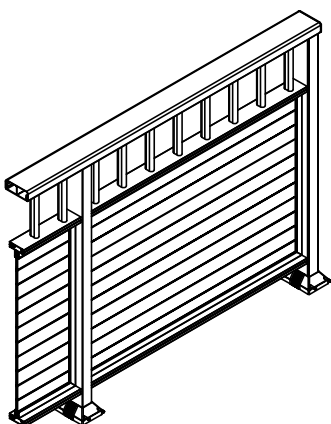

Tip: D-86

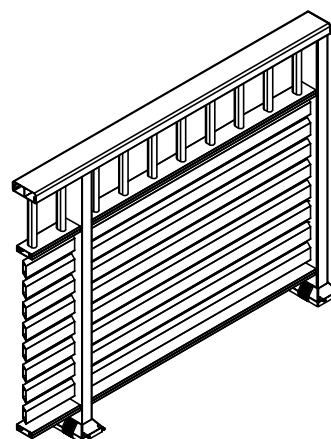

Tip: E-86

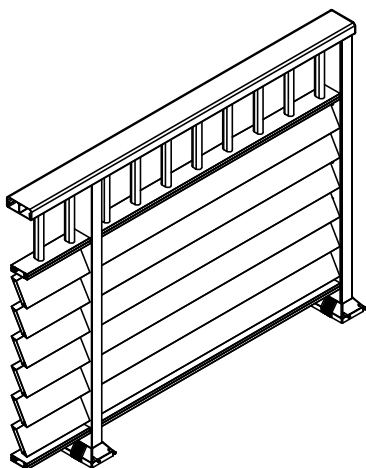

Tip: F-86

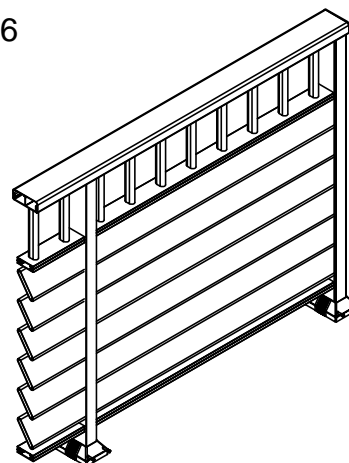

Tip: G-86

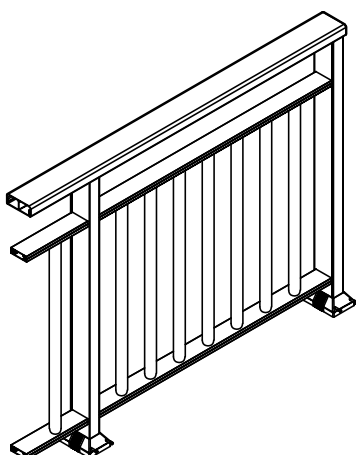

Tip: H-86

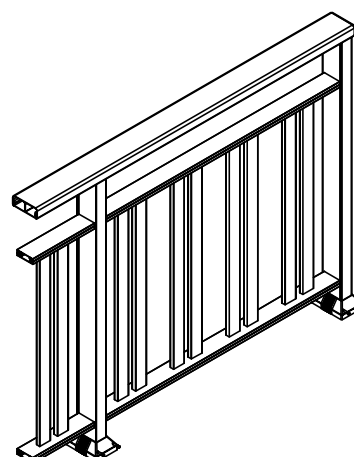

Tip: I-86

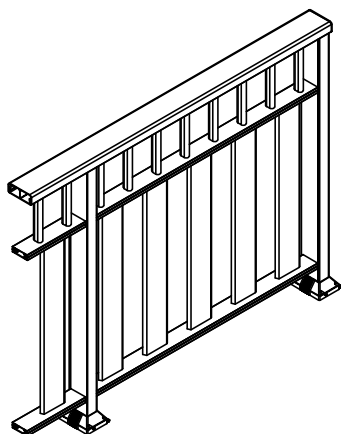

Tip: J-86

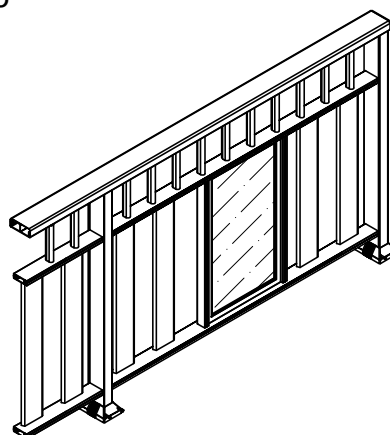

Tip: K-86

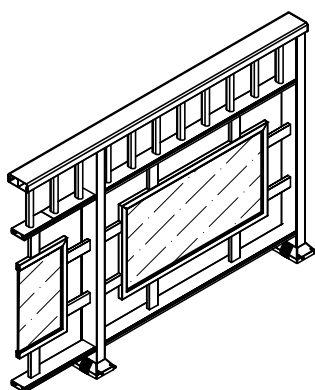

Tip: L-86

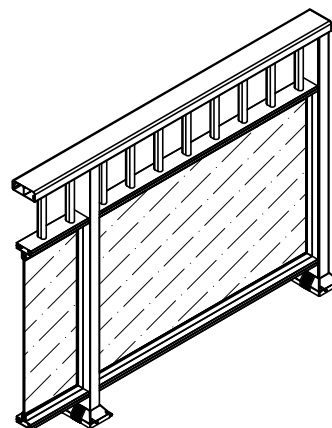



#### OF-80 Tip A-86

#### 1. Profili koji se koriste u segmentu:

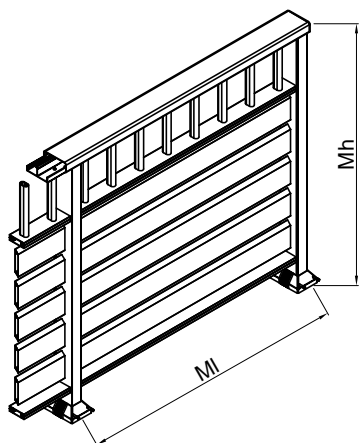

M 1:4

Profil segmenta	
F-1666 T=0.68kg/m	
F-1668 T=1.71kg/m	
F-1667 T=0.60kg/m	
F-1663 T=0.83kg/m	
F-1096 T=0.97kg/m	
F-1097 T=1.14kg/m	
OG-111 T=0.44kg/m	

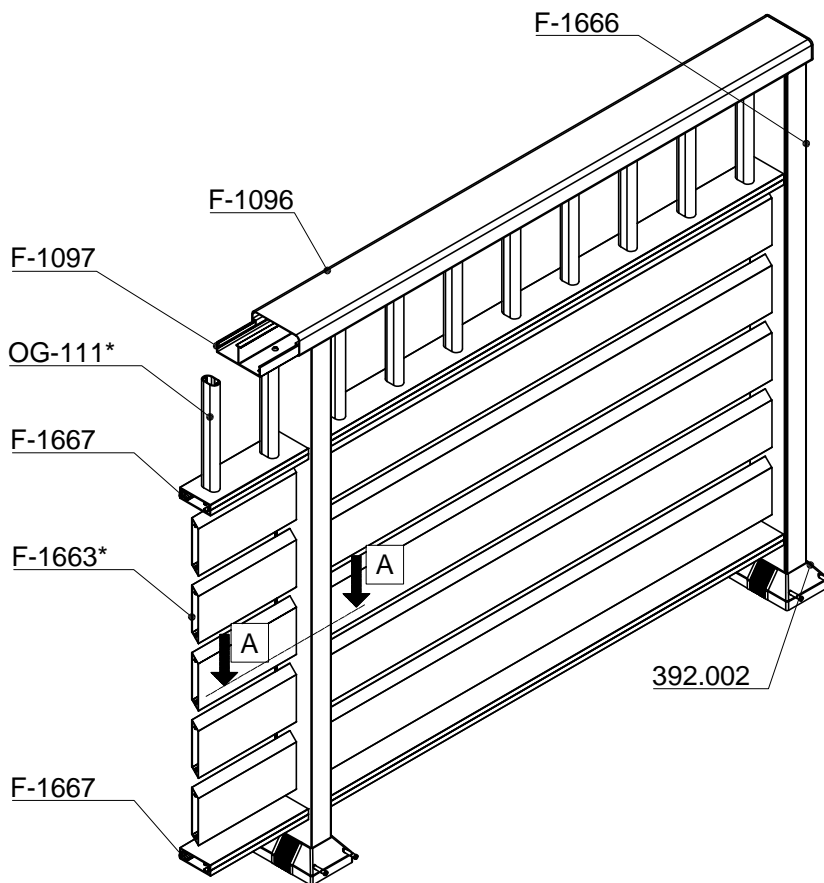

\* - mogućnost većeg izbora profila  
 -str.br. 709.09.049 gornji dio segmenta  
 -str.br.709.09.042 donji dio segmenta

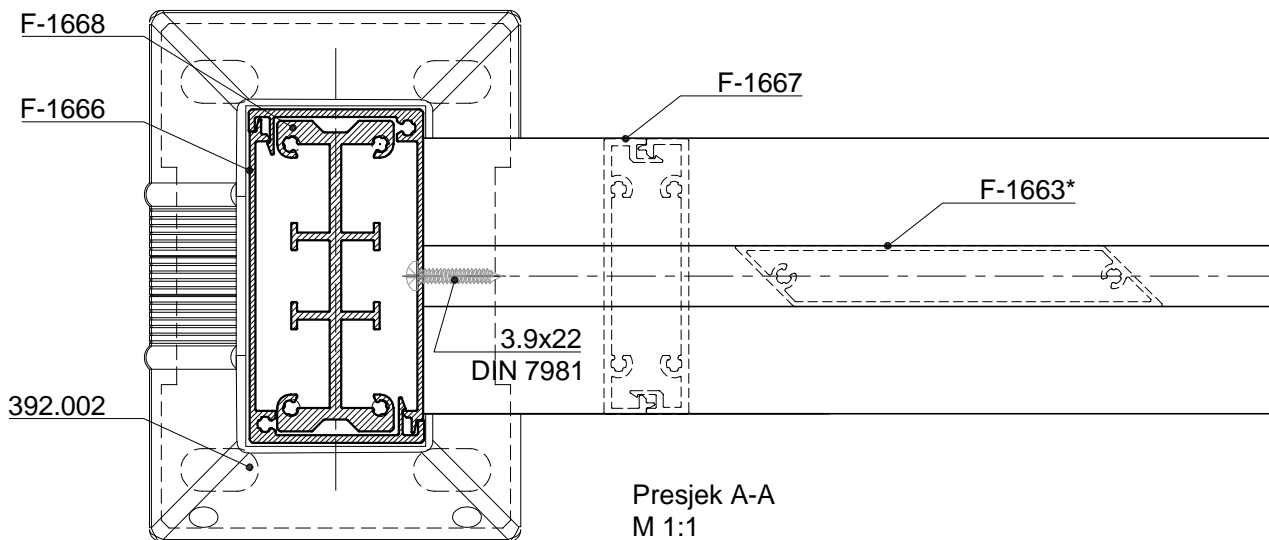





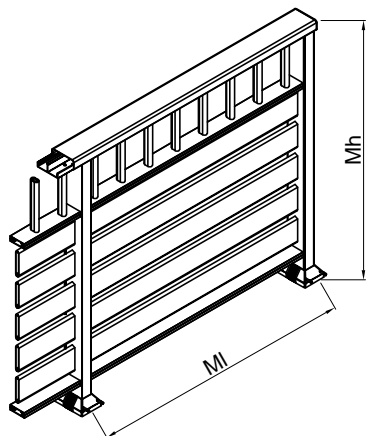

M 2:1

#### OF-80 Tip B-86

#### 1. Profili koji se koriste u segmentu:



M 1:4

Profil segmenta	
F-1666 T=0.68kg/m	
F-1668 T=1.71kg/m	
F-1667 T=0.60kg/m	
F-1662 T=0.83kg/m	 *
F-1096 T=0.97kg/m	
F-1097 T=1.14kg/m	
OG-111 T=0.44kg/m	 *

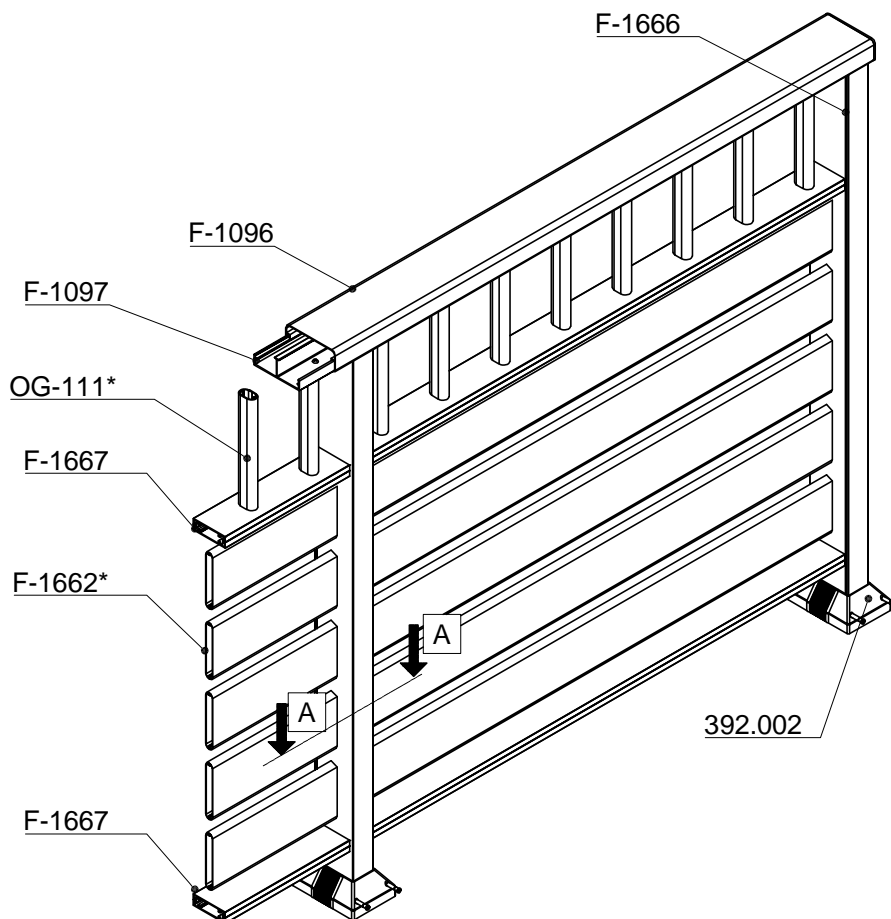

\* - mogućnost većeg izbora profila  
 -str.br. 709.09.049 gornji dio segmenta  
 -str.br.709.09.042 donji dio segmenta

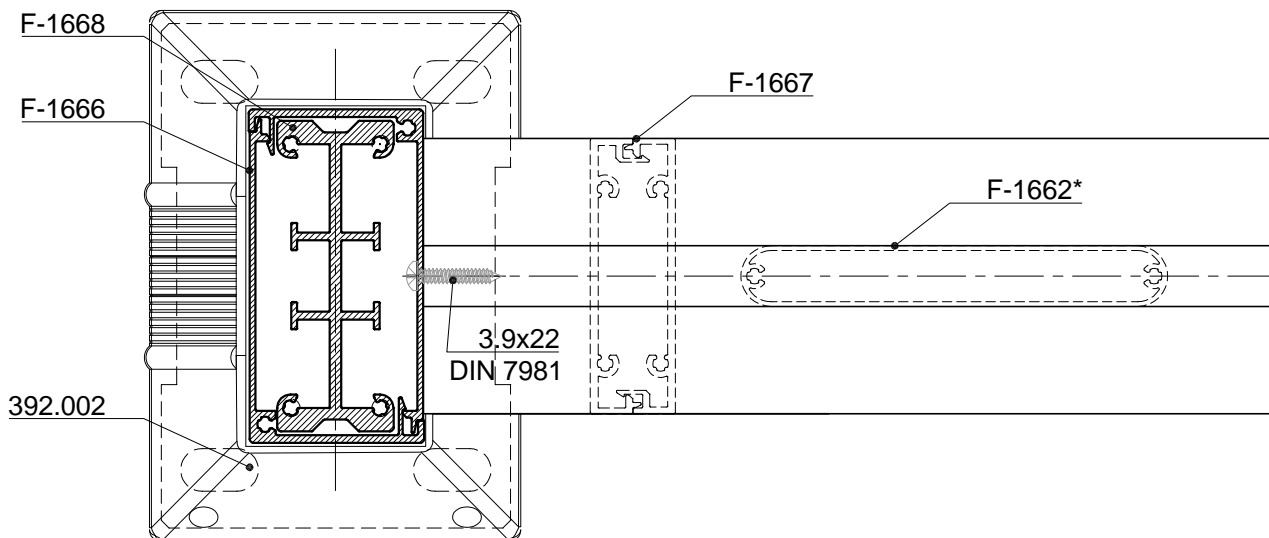

Presjek A-A  
M 1:1

M 2:1

#### OF-80 Tip C-86

#### 1. Profili koji se koriste u segmentu:

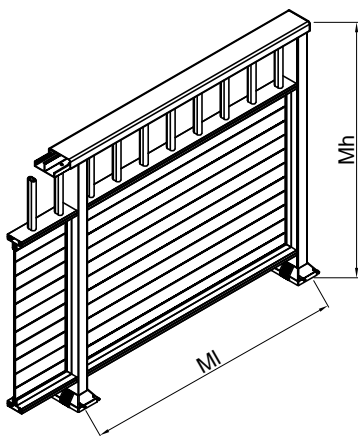

M 1:4

Profil segmenta	
F-1666 T=0.68kg/m	
F-1668 T=1.71kg/m	
F-1667 T=0.60kg/m	
F-0714 T=0.89kg/m	
F-1096 T=0.97kg/m	
F-1097 T=1.14kg/m	
OG-111 T=0.44kg/m	*
F-1664 T=0.38kg/m	

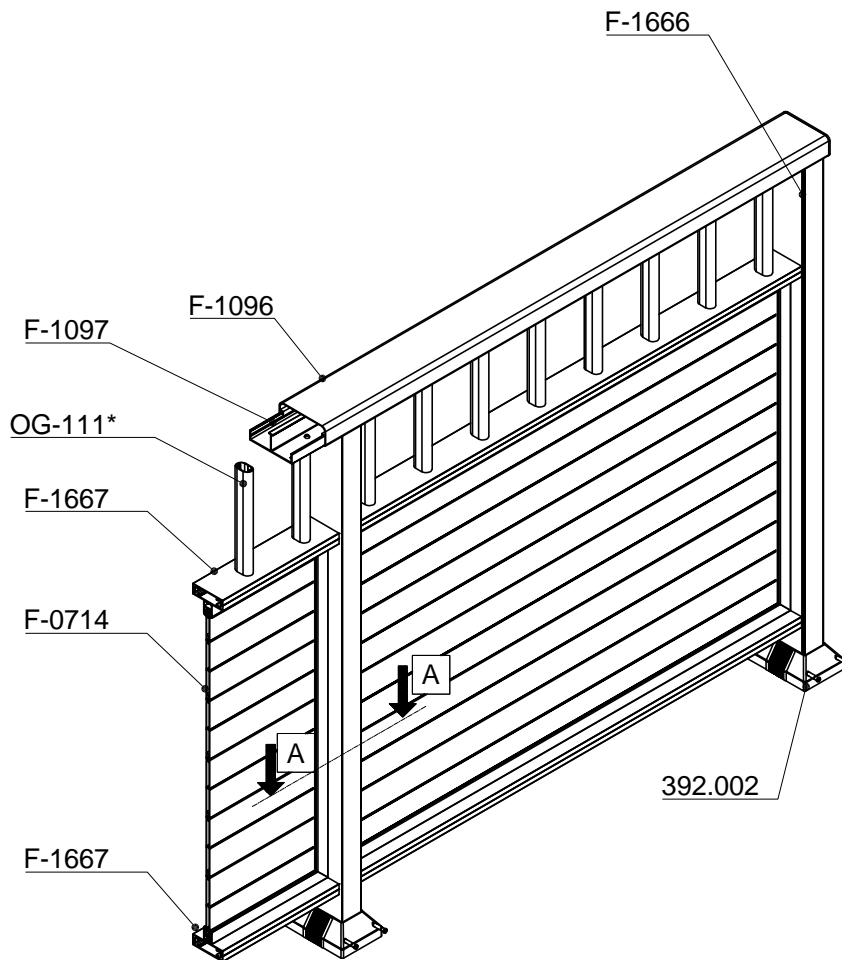

\* - mogućnost većeg izbora profila  
-str.br. 709.09.049 gornji dio segmenta

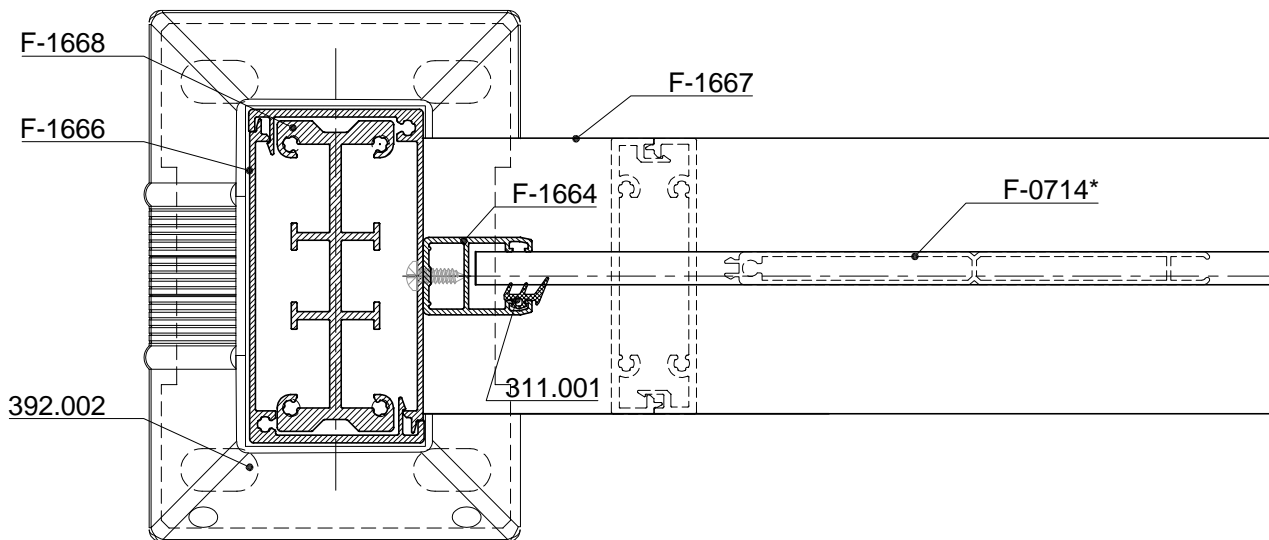

Presjek A-A  
M 1:1

M 2:1

#### OF-80 Tip D-86

#### 1. Profili koji se koriste u segmentu:

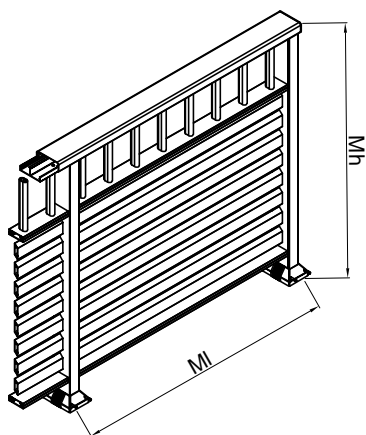

M 1:4

Profil segmenta	
F-1666 T=0.68kg/m	
F-1668 T=1.71kg/m	
F-1667 T=0.60kg/m	
F-1455 T=0.50kg/m	
F-1096 T=0.97kg/m	
F-1097 T=1.14kg/m	
OG-111 T=0.44kg/m	

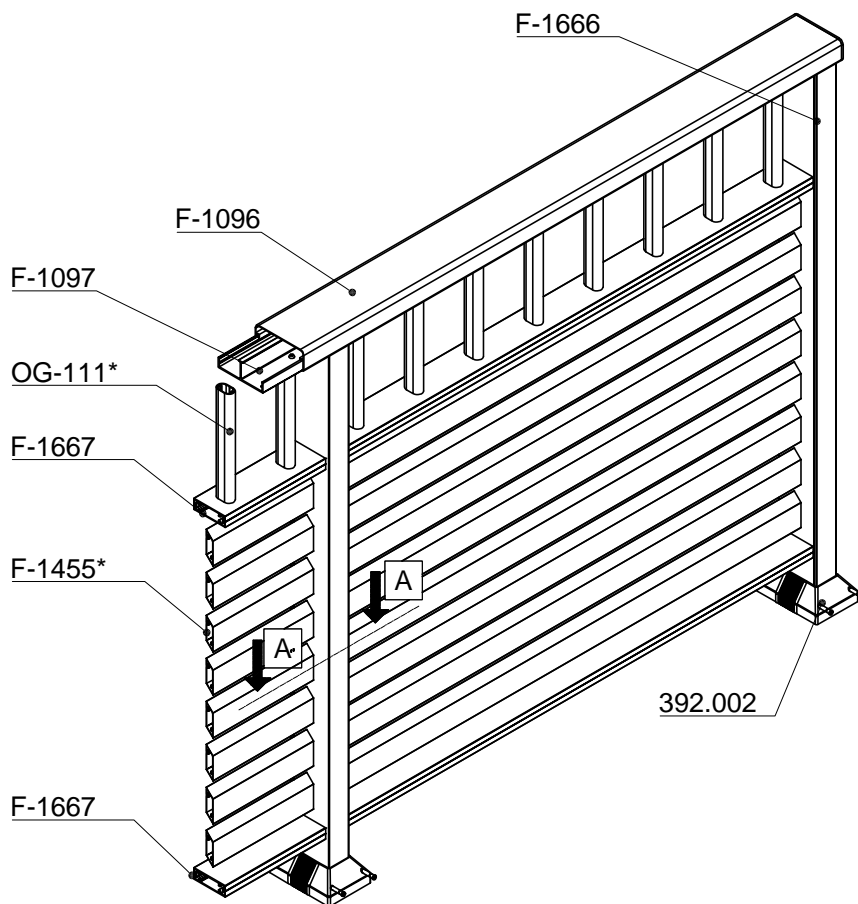

\* - mogućnost većeg izbora profila  
 -str.br. 709.09.049 gornji dio segmenta  
 -str.br.709.09.042 donji dio segmenta

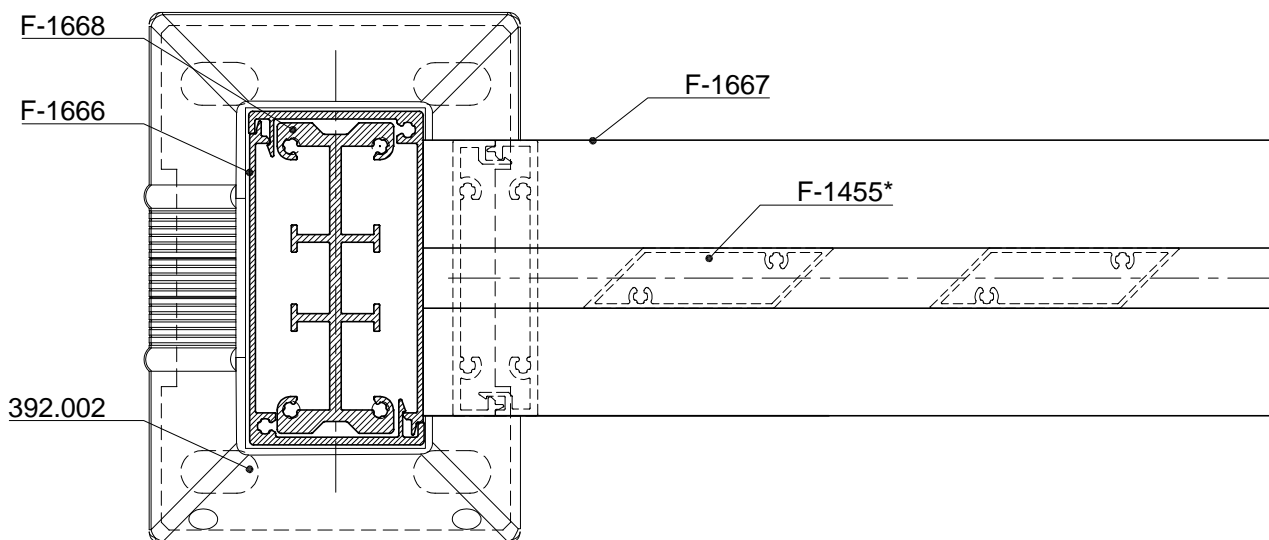

Presjek A-A  
 M 1:1

M 2:1

#### OF-80 Tip E-86

#### 1. Profili koji se koriste u segmentu:

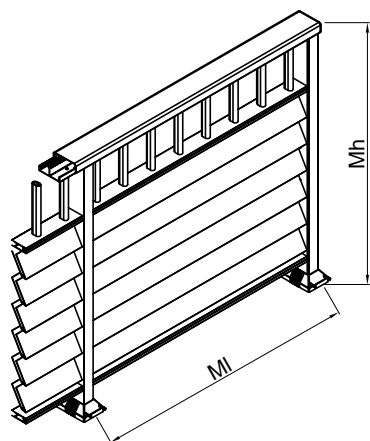

M 1:4

Profil segmenta	
F-1666 T=0.68kg/m	
F-1668 T=1.71kg/m	
F-1667 T=0.60kg/m	
F-1663 T=0.83kg/m	
F-1096 T=0.97kg/m	
F-1097 T=1.14kg/m	
OG-111 T=0.44kg/m	

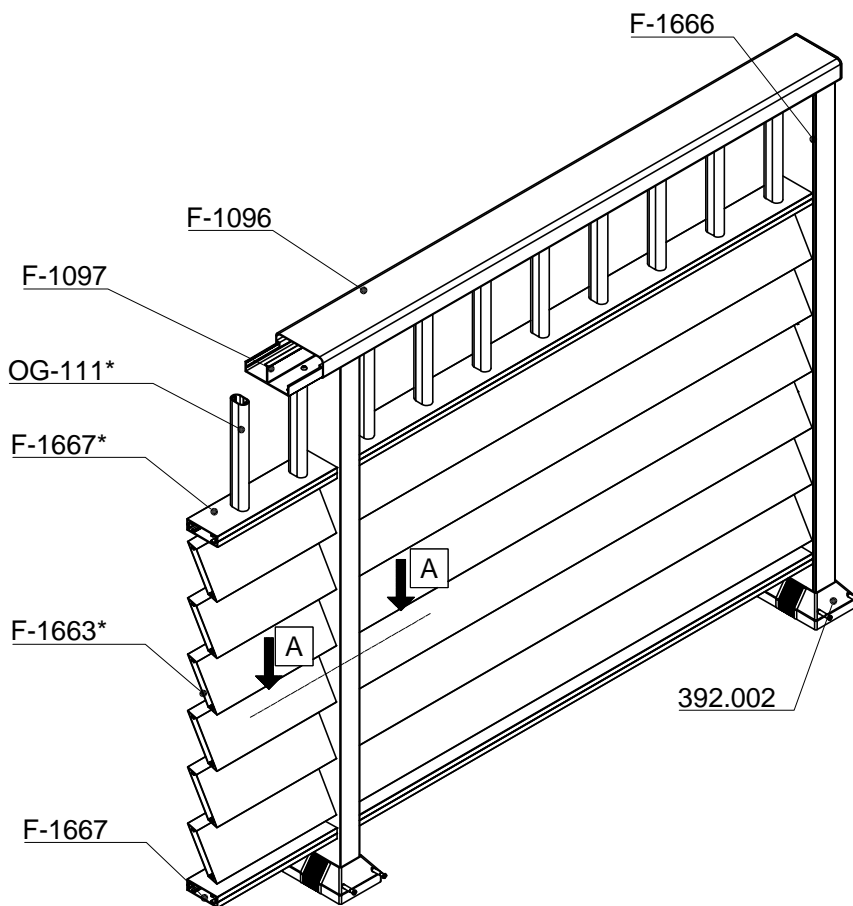

- \* - mogućnost većeg izbora profila
- str.br. 709.09.049 gornji dio segmenta
- str.br.709.09.042 donji dio segmenta

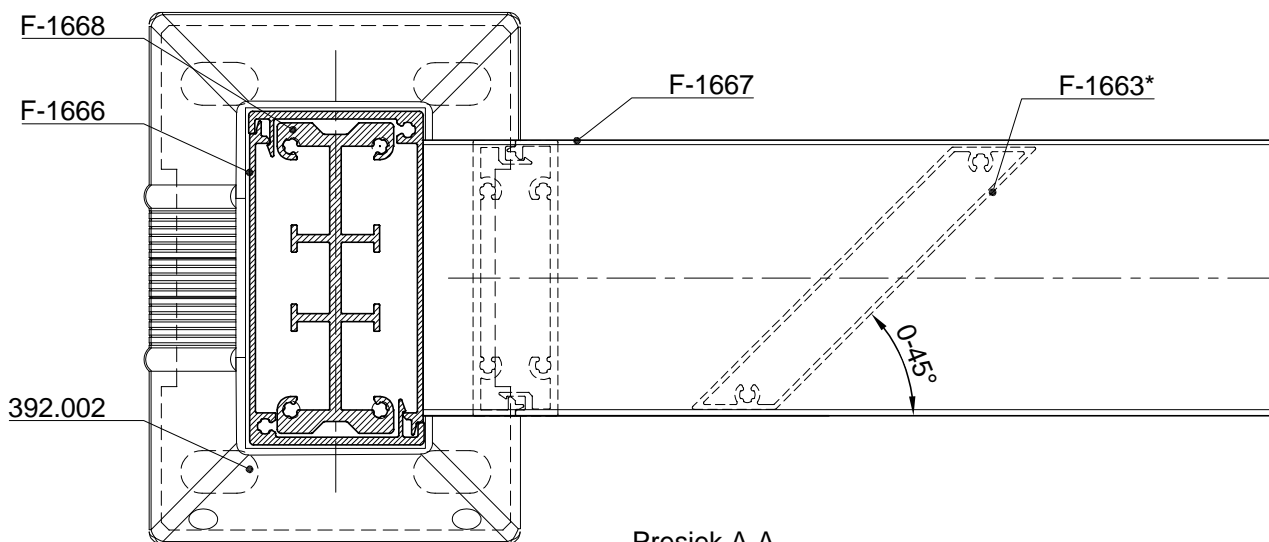

Presjek A-A  
M 1:1

M 2:1

#### OF-80 Tip F-86

#### 1. Profili koji se koriste u segmentu:

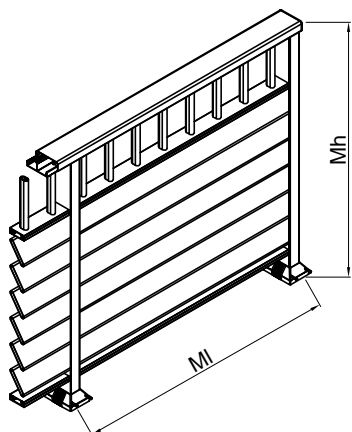

M 1:4

Profil segmenta	
F-1666 T=0.68kg/m	
F-1668 T=1.71kg/m	
F-1667 T=0.60kg/m	
F-1662 T=0.83kg/m	
F-1096 T=0.97kg/m	
F-1097 T=1.14kg/m	
OG-111 T=0.44kg/m	

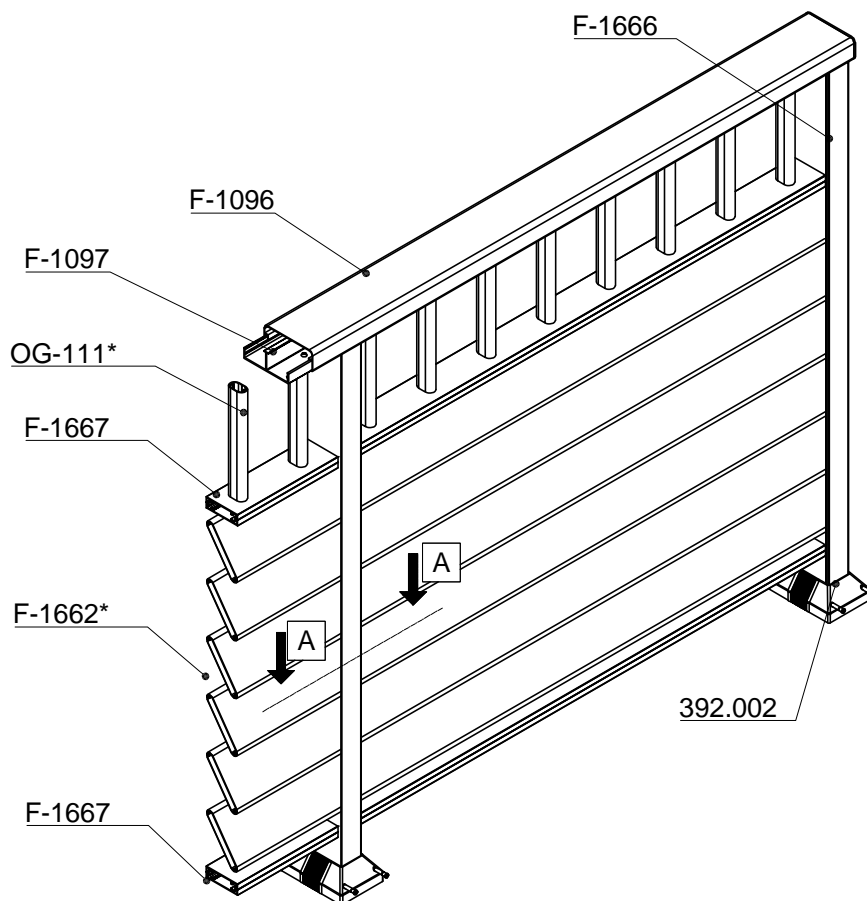

\* - mogućnost većeg izbora profila

-str.br. 709.09.049 gornji dio segmenta

-str.br.709.09.042 donji dio segmenta

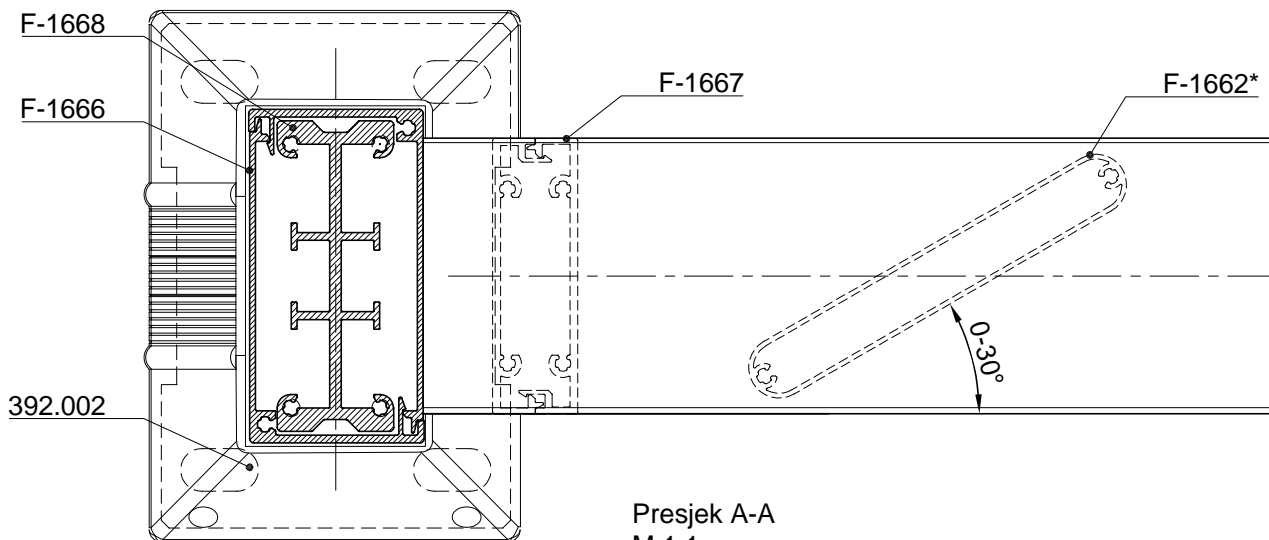

Presjek A-A  
M 1:1

M 2:1

#### OF-80 Tip G-86

#### 1. Profili koji se koriste u segmentu:

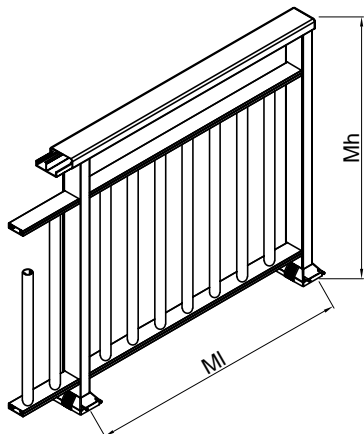

M 1:4

Profil segmenta	
F-1666 T=0.68kg/m	
F-1668 T=1.71kg/m	
F-1667 T=0.60kg/m	
F-1096 T=0.97kg/m	
F-1097 T=1.14kg/m	
F-0829 T=0.30kg/m	

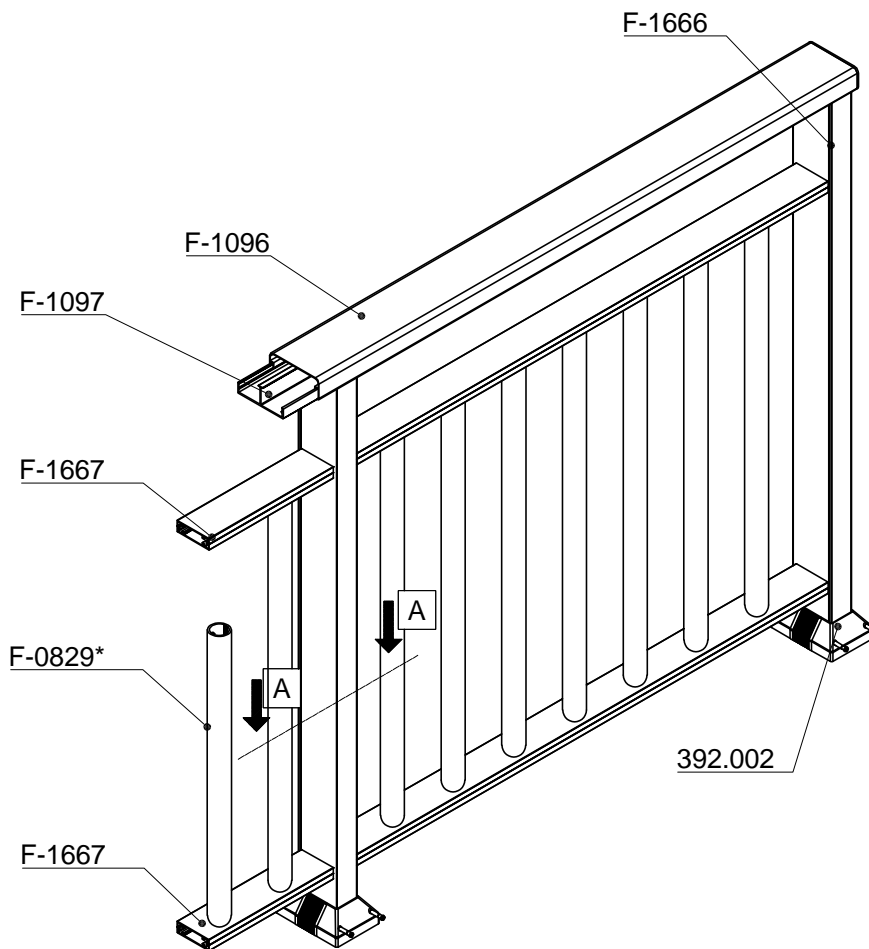

\* - mogućnost većeg izbora profila  
-str.br.709.09.043 donji dio segmenta

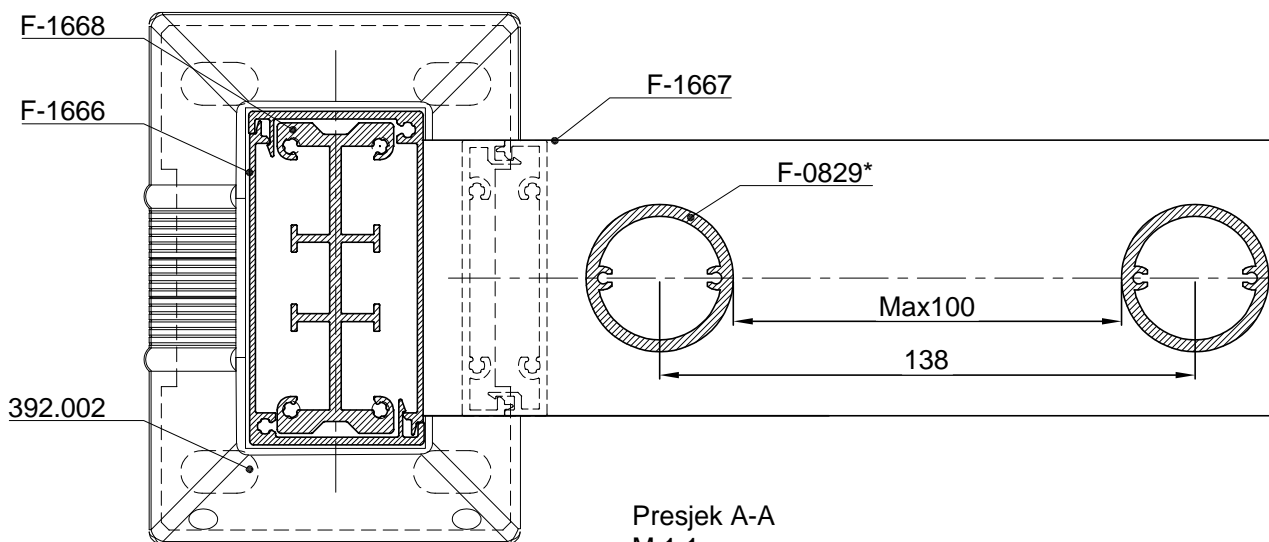

Presjek A-A  
M 1:1

M 2:1

#### OF-80 Tip H-86

#### 1. Profili koji se koriste u segmentu:

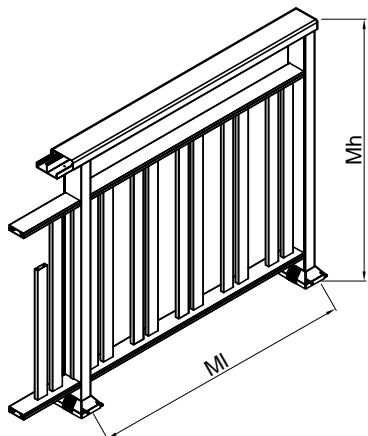

M 1:4

Profil segmenta	
F-1666 T=0.68kg/m	
F-1668 T=1.71kg/m	
F-1667 T=0.60kg/m	
F-1096 T=0.97kg/m	
F-1097 T=1.14kg/m	
F-1541 T=0.61kg/m	*

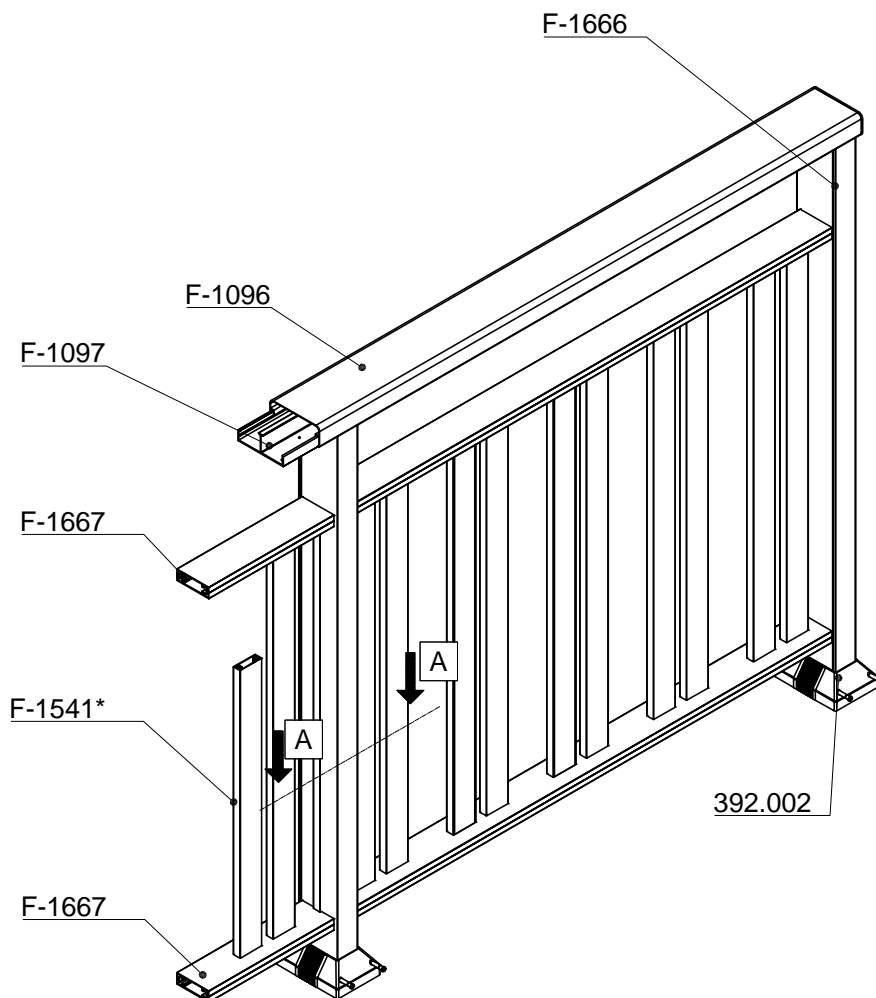

\* - mogućnost većeg izbora profila  
-str.br.709.09.043 donji dio segmenta

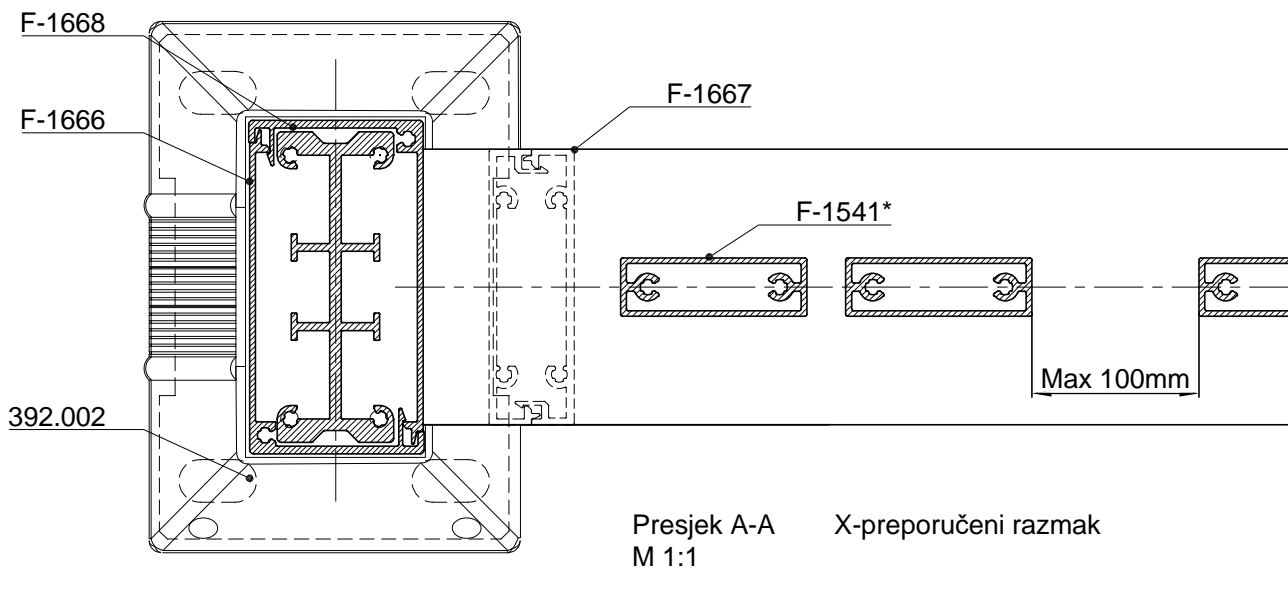

#### OF-80 Tip I-86

#### 1. Profili koji se koriste u segmentu:

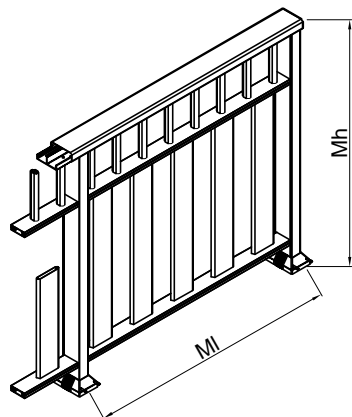

M 1:4

Profil segmenta	
F-1666 T=0.68kg/m	
F-1668 T=1.71kg/m	
F-1667 T=0.60kg/m	
F-1662 T=0.83kg/m	
F-1096 T=0.97kg/m	
F-1097 T=1.14kg/m	
OG-111 T=0.44kg/m	

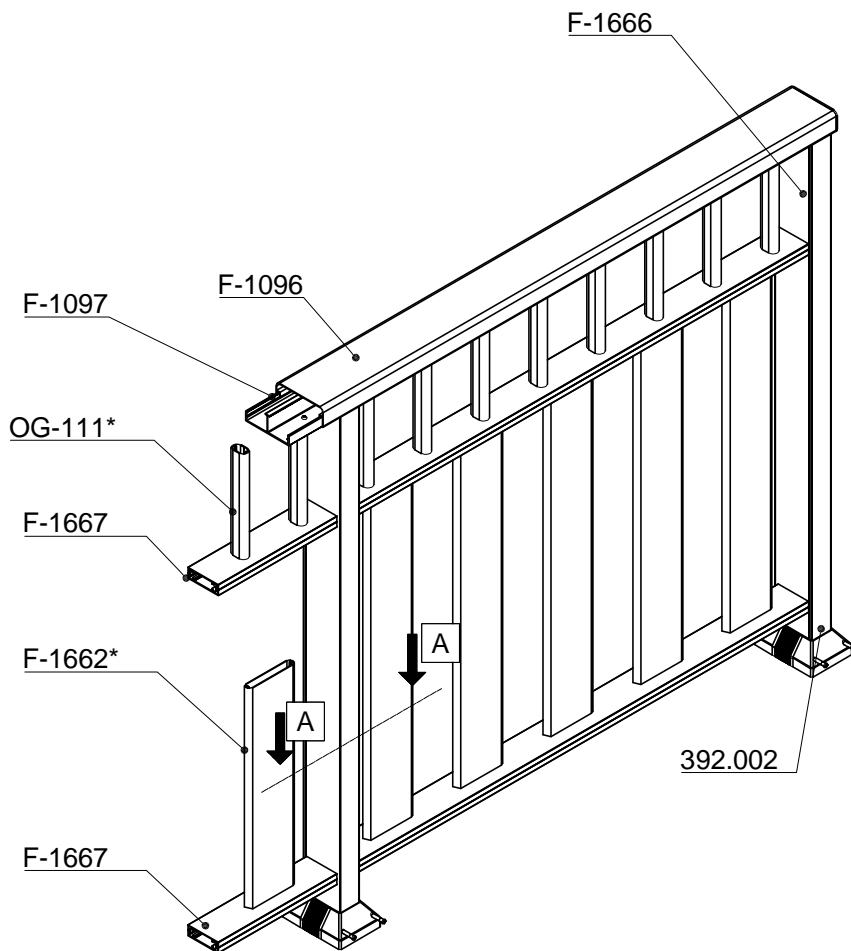

\* - mogućnost većeg izbora profila  
 -str.br. 709.09.049 gornji dio segmenta  
 -str.br.709.09.043 donji dio segmenta

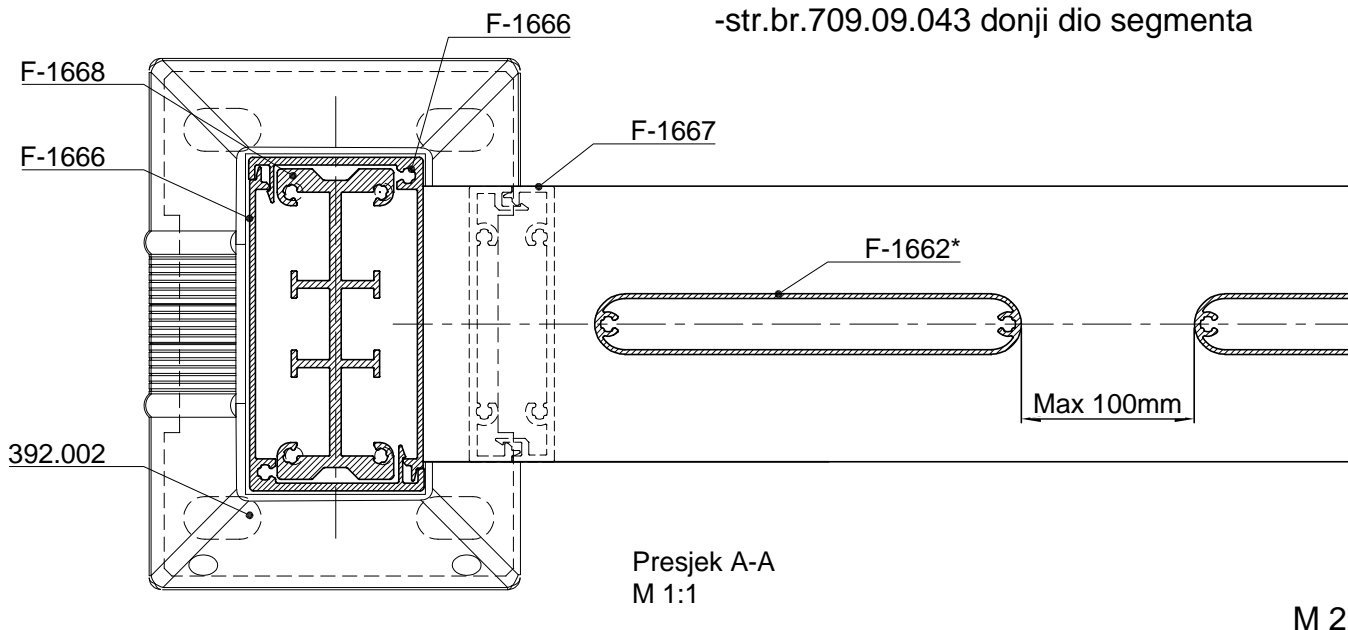

#### OF-80 Tip J-86

#### 1. Profili koji se koriste u segmentu:

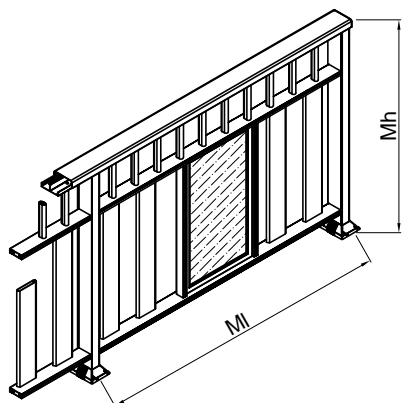

M 1:4

Profil segmenta	
F-1666 T=0.68kg/m	
F-1668 T=1.71kg/m	
F-1667 T=0.60kg/m	
F-1662 T=0.83kg/m	
F-1096 T=0.97kg/m	
F-1097 T=1.14kg/m	
OG-111 T=0.44kg/m	
F-1664 T=0.38kg/m	

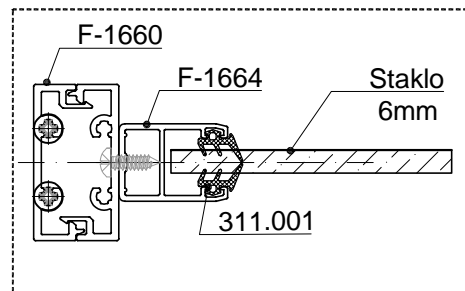
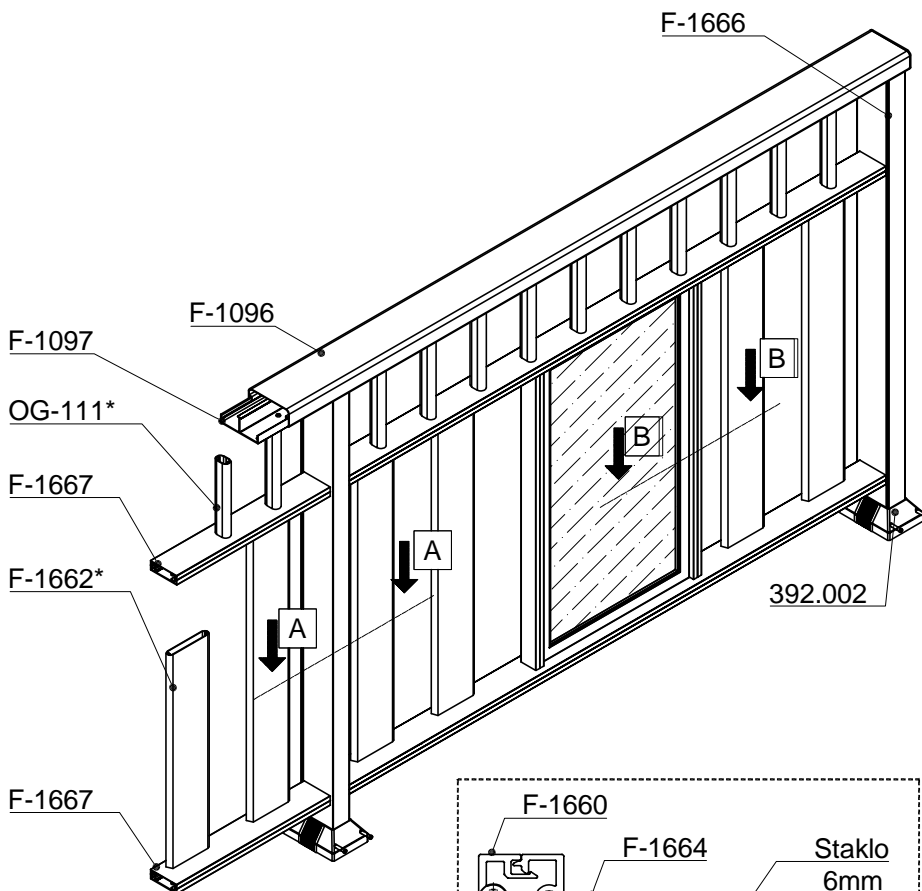

Presjek B-B  
M 1:1

\* - mogućnost većeg izbora profila  
 -str.br. 709.09.049 gornji dio segmenta  
 -str.br.709.09.043 donji dio segmenta

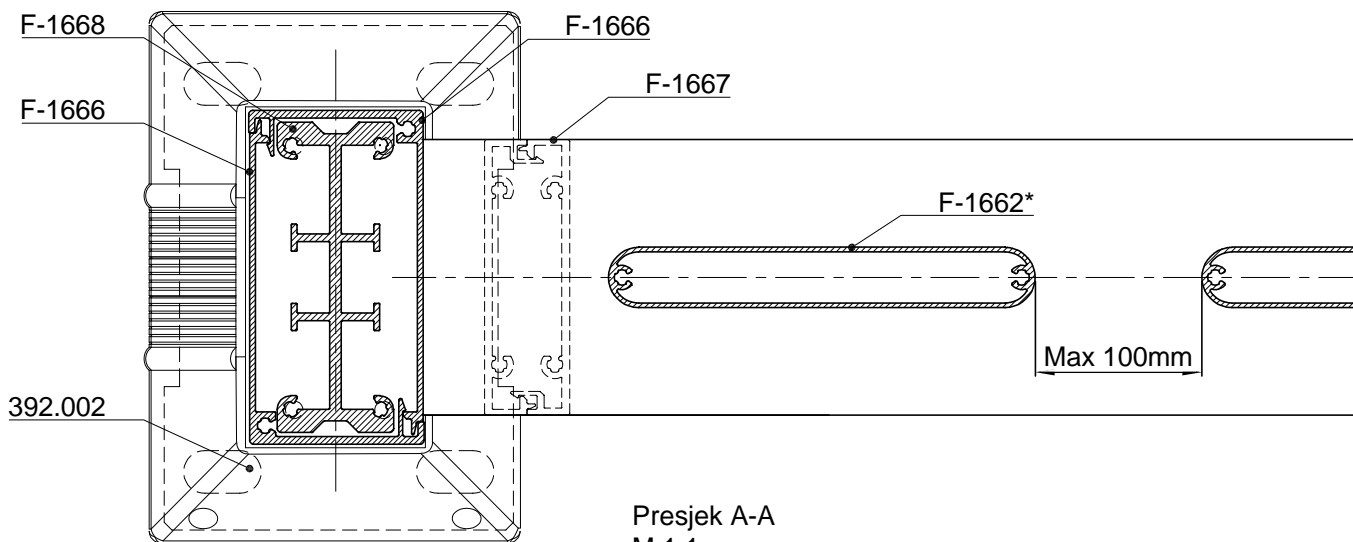

Presjek A-A  
M 1:1

M 2:1

#### OF-80 Tip K-86

#### 1. Profili koji se koriste u segmentu:

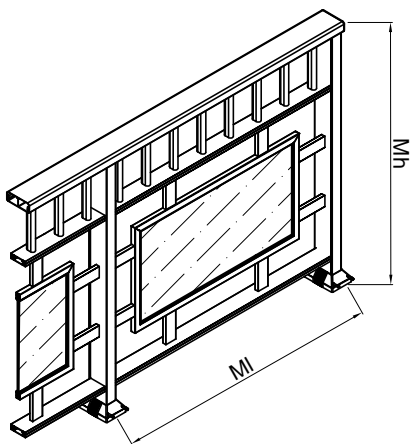

M 1:4

Profil segmenta	
F-1666 T=0.68kg/m	
F-1668 T=1.71kg/m	
F-1667 T=0.60kg/m	
F-1541 T=0.61kg/m	
F-1096 T=0.97kg/m	
F-1097 T=1.14kg/m	
OG-111 T=0.44kg/m	*
F-1664 T=0.38kg/m	

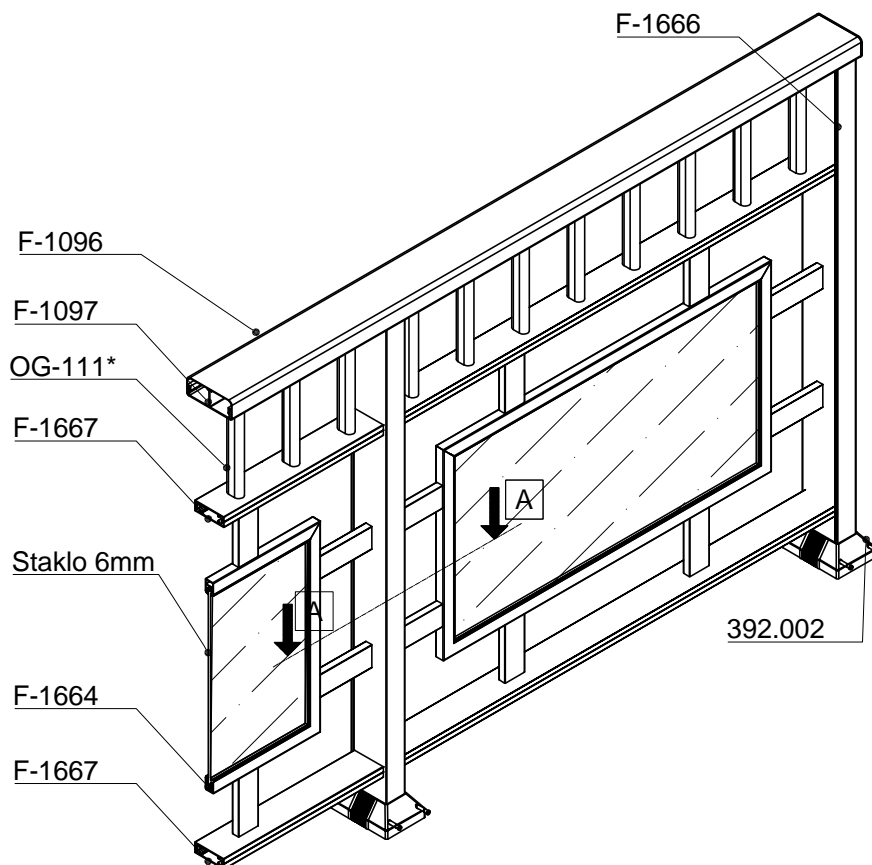

\* - mogućnost većeg izbora profila  
-str.br. 709.09.049 gornji dio segmenta

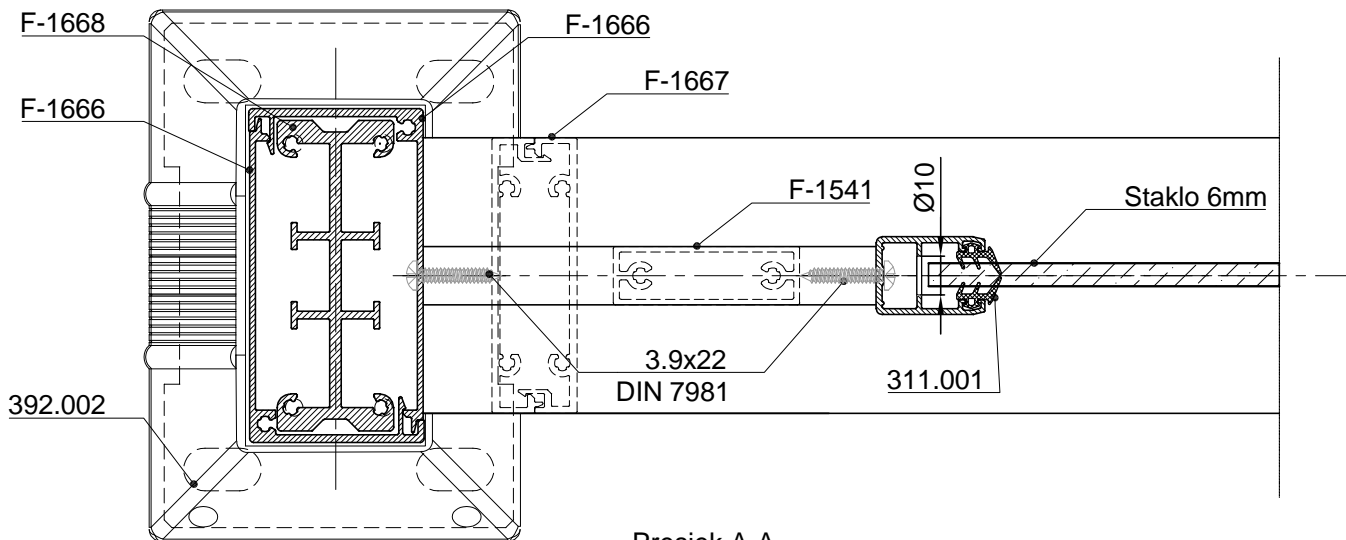

Presjek A-A  
M 1:1

M 2:1

#### OF-80 Tip L-86

#### 1. Profili koji se koriste u segmentu:

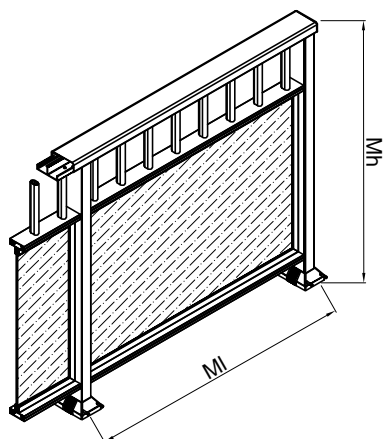

M 1:4

Profil segmenta	
F-1666 T=0.68kg/m	
F-1668 T=1.71kg/m	
F-1667 T=0.60kg/m	
F-1096 T=0.97kg/m	
F-1097 T=1.14kg/m	
OG-111 T=0.44kg/m	
F-1664 T=0.38kg/m	

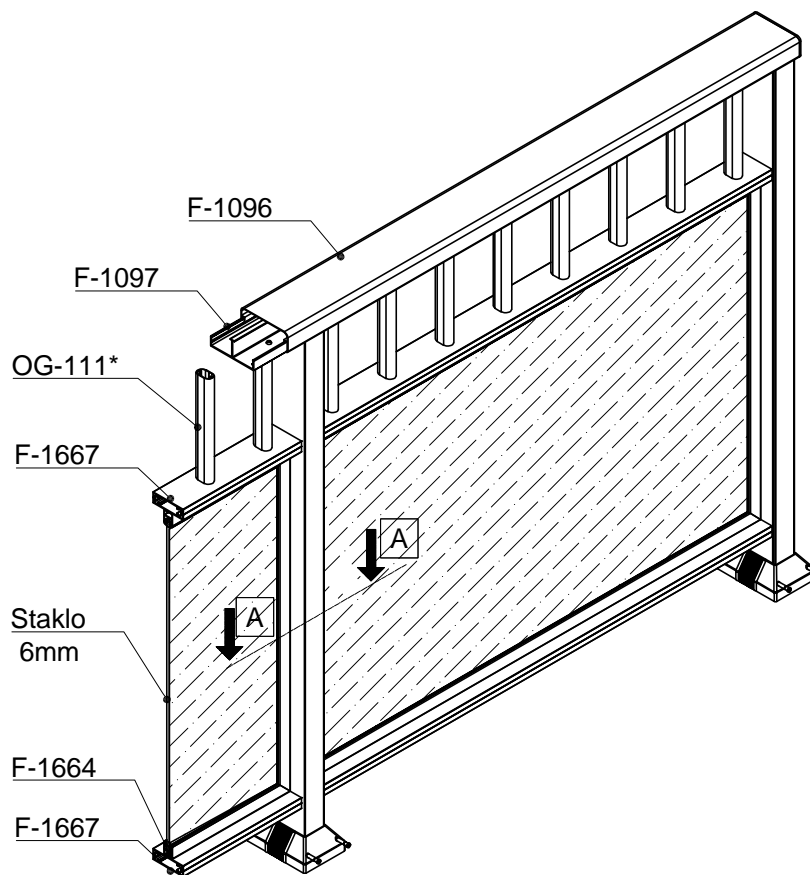

\* - mogućnost većeg izbora profila  
-str.br. 709.09.049 gornji dio segmenta

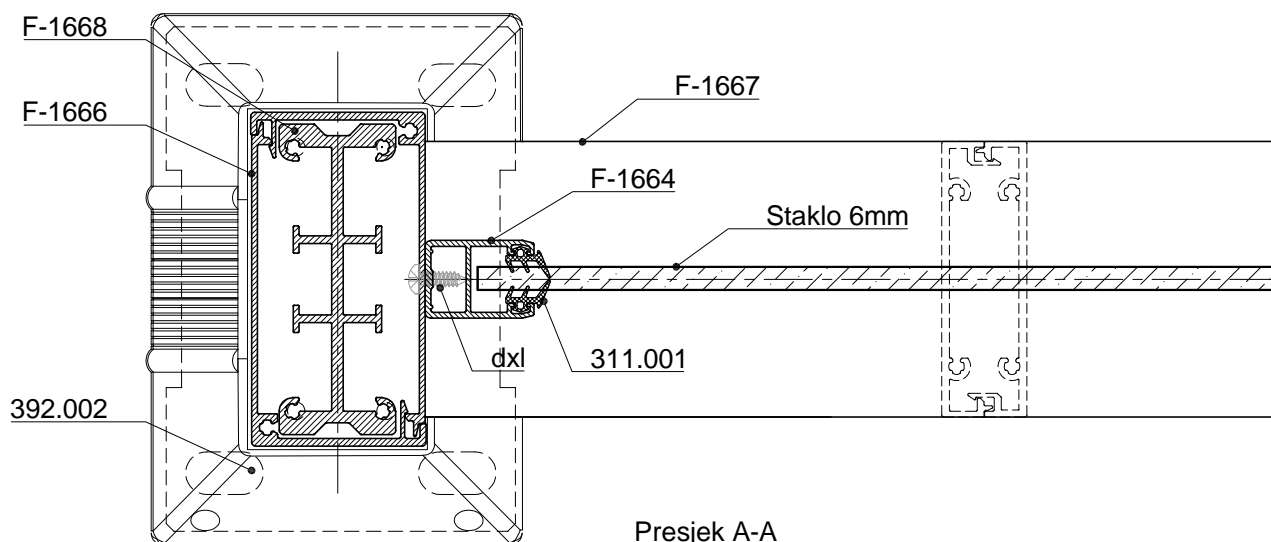

Presjek A-A  
M 1:1

M 2:1

# Sheme

Tip: A-45

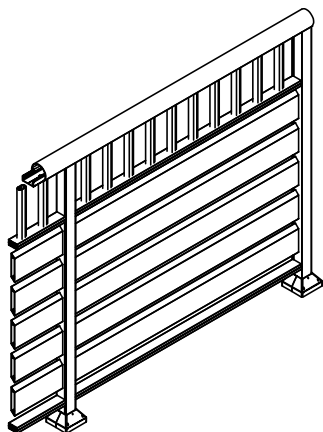

Tip: B-45

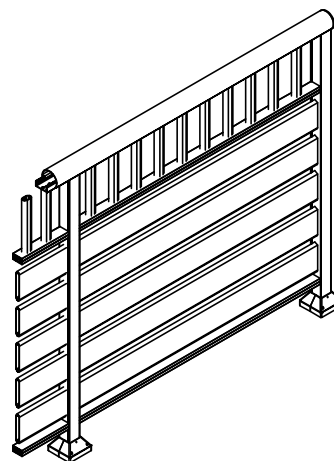

Tip: C-45

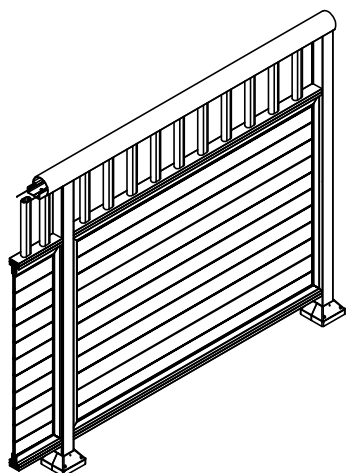

Tip: D-45

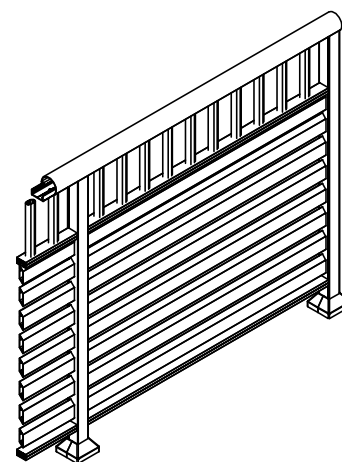

Tip: G-45

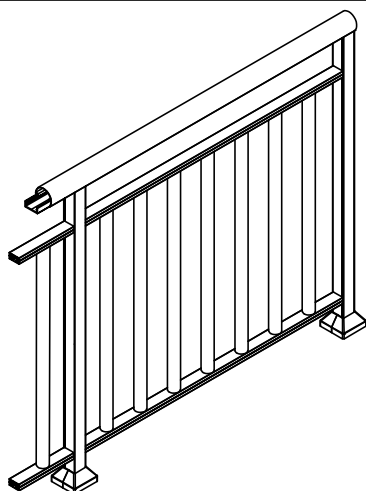

Tip: H-45

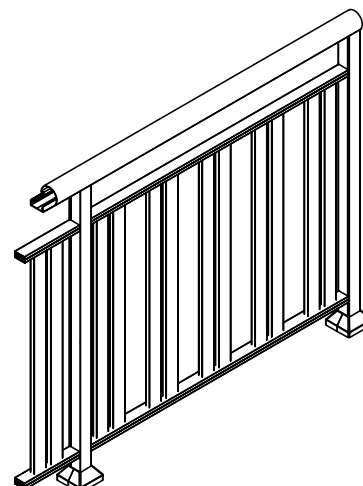

Tip: I-45

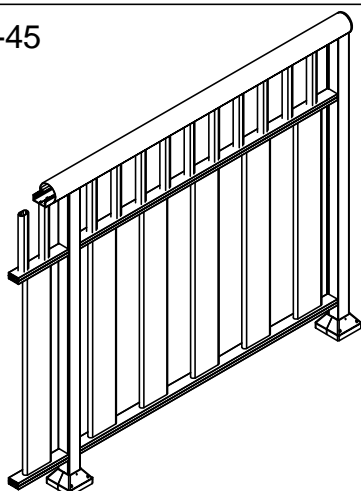

Tip: J-45

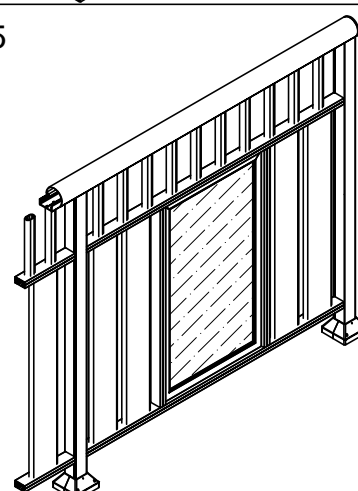

Tip: K-45

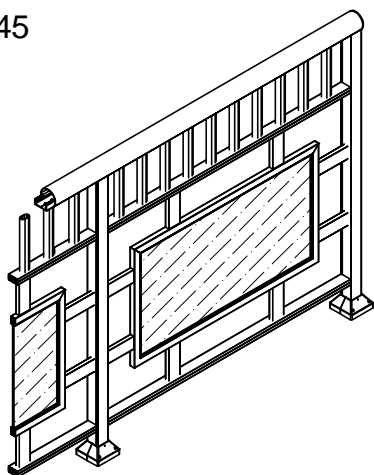

Tip: L-45

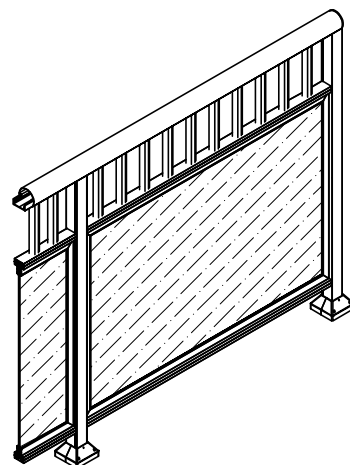

#### OF-80 Tip A-45

#### 1. Profili koji se koriste u segmentu:

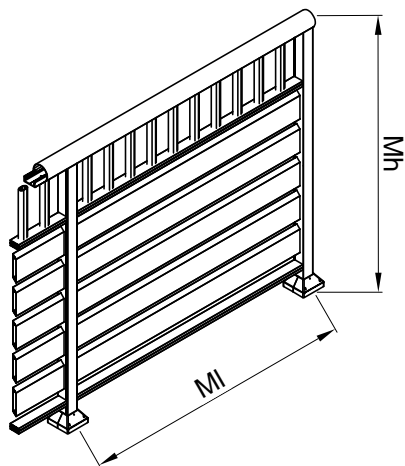

M 1:4

Profili segmenta	
F-1659 T=0.51kg/m	
F-1665 T=1.33kg/m	
F-1660 T=0.43kg/m	
F-0621 T=0.83kg/m	*
F-0620 T=0.60kg/m	
F-1663 T=0.83kg/m	*
OG-111 T=0.44kg/m	*

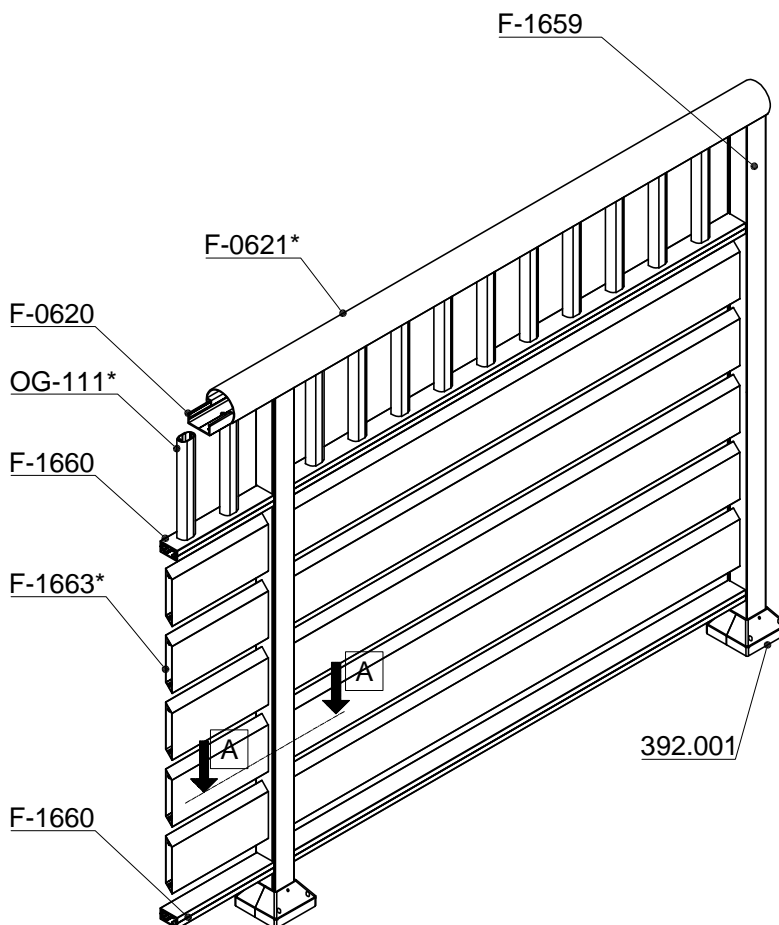

- \* - mogućnost većeg izbora profila  
 -str.br. 709.09.048 gornji dio segmenta  
 -str.br.709.09.042 donji dio segmenta  
 -str.br.709.09.051 izbor rukohvata

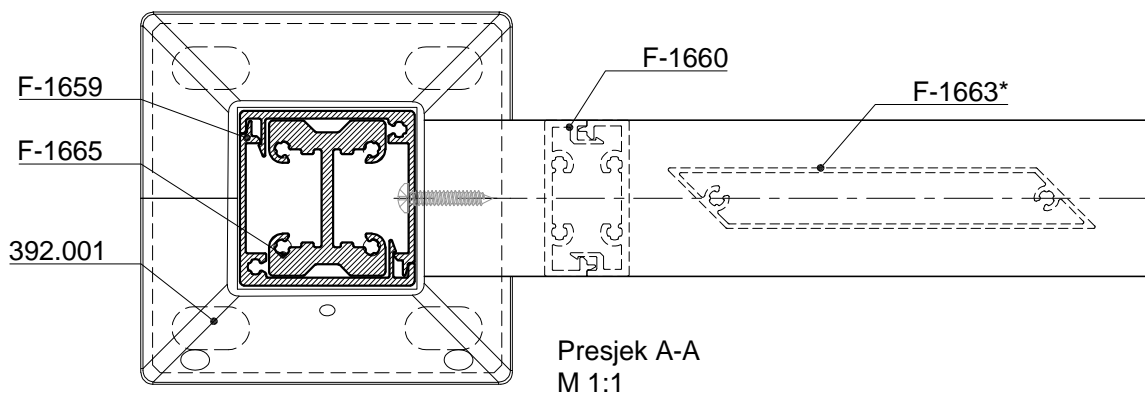

M 2:1

#### OF-80 Tip B-45

#### 1. Profili koji se koriste u segmentu:

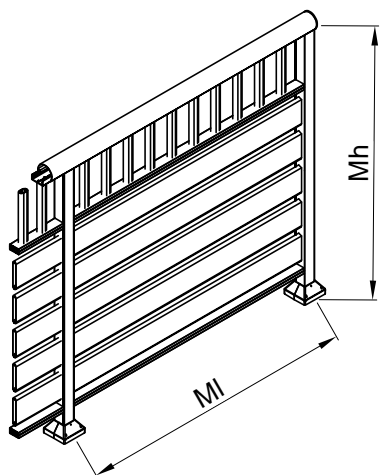

M 1:4

Profili segmenta	
F-1659 T=0.51kg/m	
F-1665 T=1.33kg/m	
F-1660 T=0.43kg/m	
F-0621 T=0.83kg/m	*
F-0620 T=0.60kg/m	
F-1662 T=0.83kg/m	*
OG-111 T=0.44kg/m	*

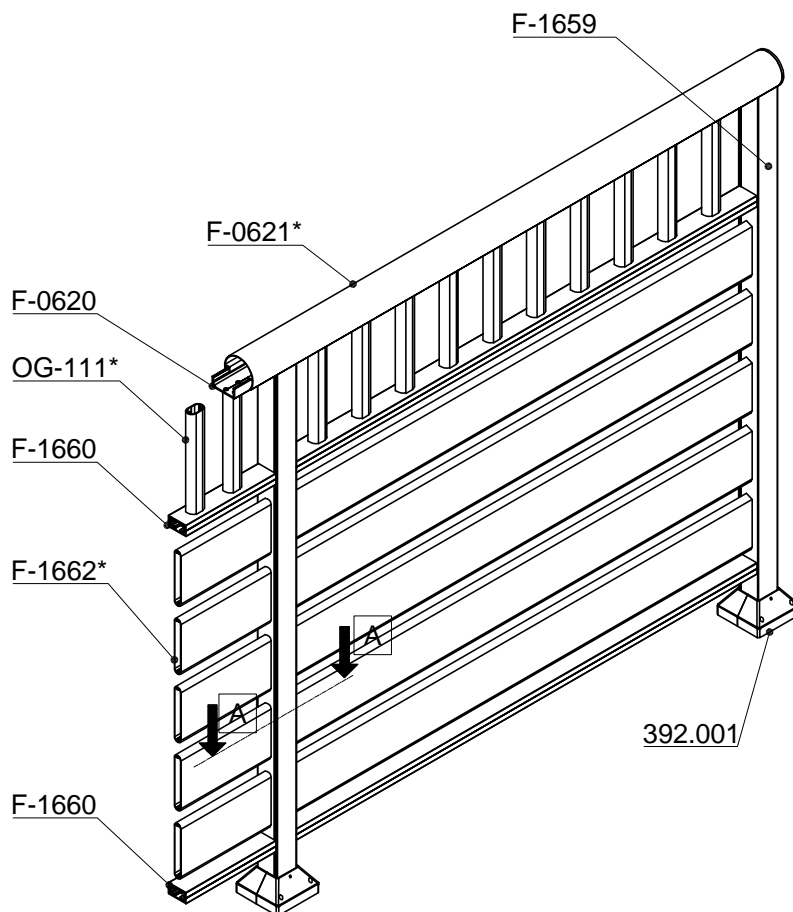

- \* - mogućnost većeg izbora profila  
 -str.br. 709.09.048 gornji dio segmenta  
 -str.br.709.09.042 donji dio segmenta  
 -str.br.709.09.051 izbor rukohvata

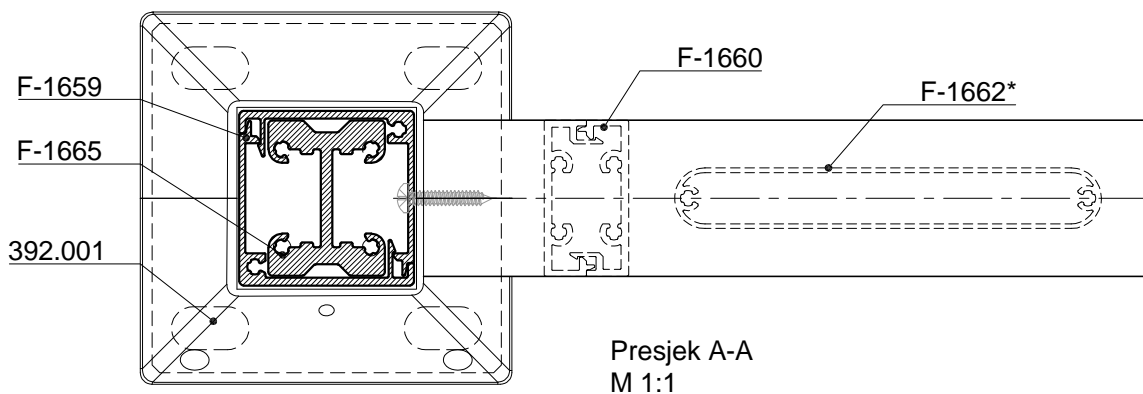

M 2:1

#### OF-80 Tip C-45

#### 1. Profili koji se koriste u segmentu:

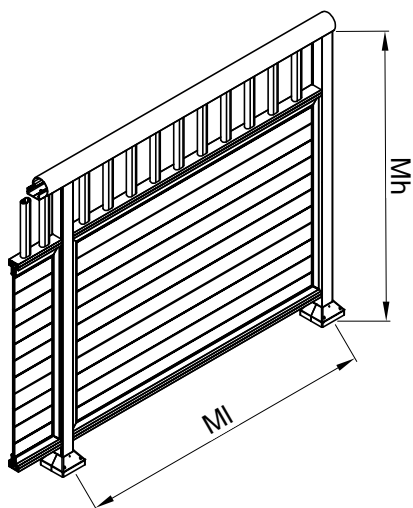

M 1:4

Profili segmenta	
F-1659 T=0.51kg/m	
F-1665 T=1.33kg/m	
F-1660 T=0.43kg/m	
F-0621 T=0.83kg/m	*
F-0620 T=0.60kg/m	
F-0714 T=0.89kg/m	
OG-111 T=0.44kg/m	*

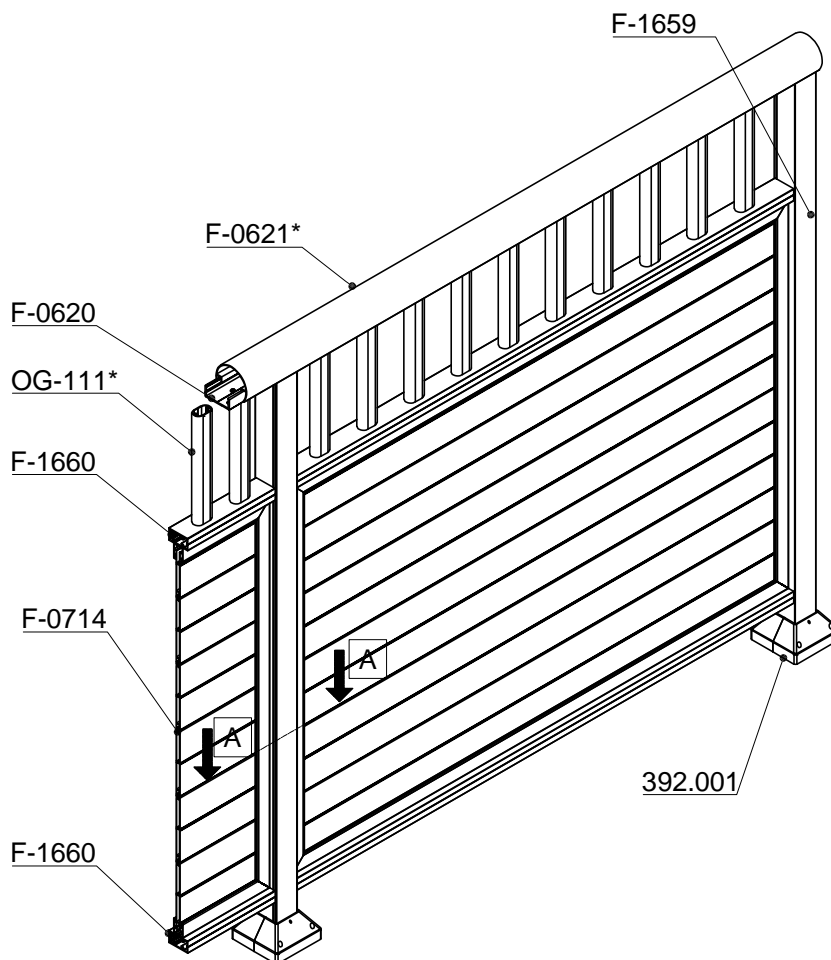

\* - mogućnost većeg izbora profila  
 -str.br. 709.09.048 gornji dio segmenta  
 -str.br.709.09.051 izbor rukohvata

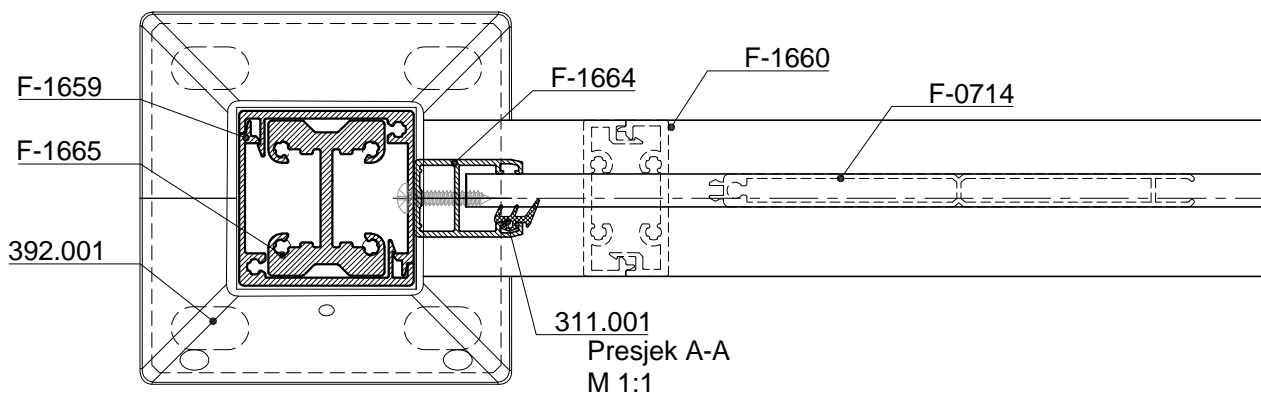

M 2:1

#### OF-80 Tip D-45

#### 1. Profili koji se koriste u segmentu:

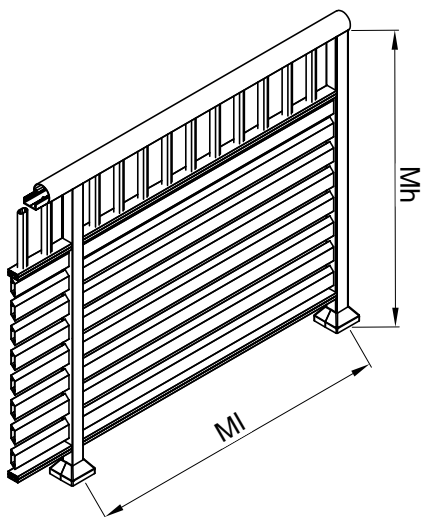

M 1:4

Profili segmenta	
F-1659 T=0.51kg/m	
F-1665 T=1.33kg/m	
F-1660 T=0.43kg/m	
F-0621 T=0.83kg/m	*
F-0620 T=0.60kg/m	
F-1455 T=0.50kg/m	*
OG-111 T=0.44kg/m	*

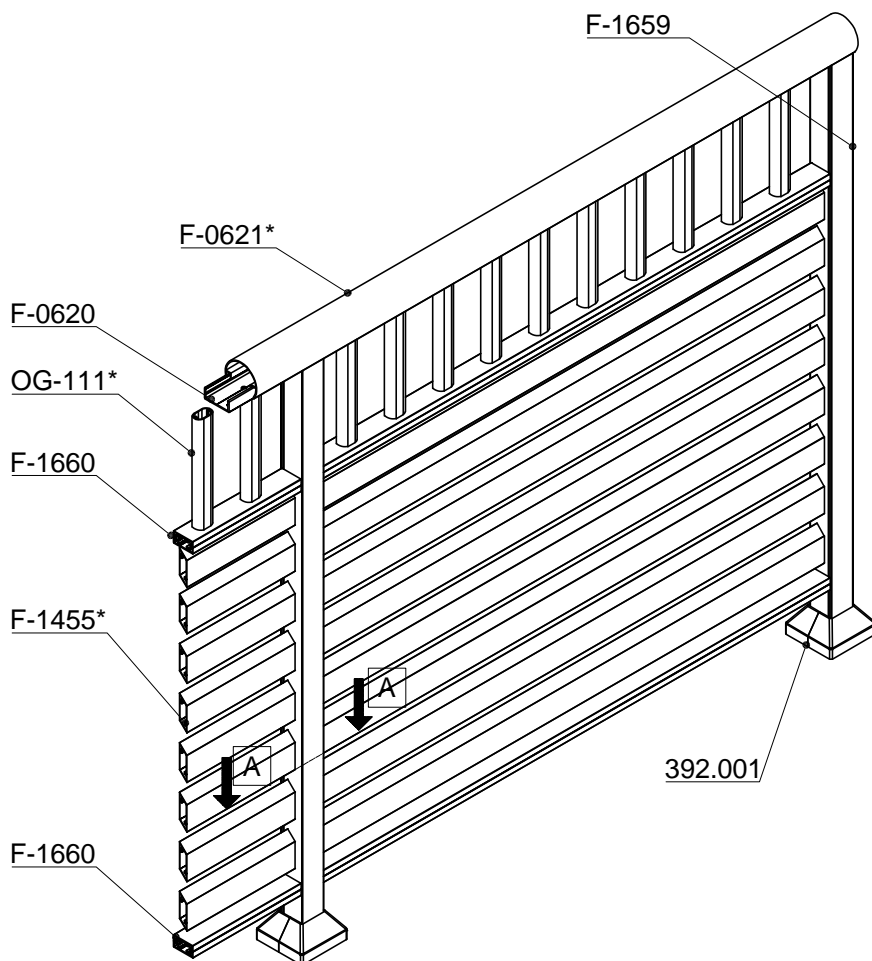

- \* - mogućnost većeg izbora profila
- str.br. 709.09.048 gornji dio segmenta
- str.br.709.09.042 donji dio segmenta
- str.br.709.09.051 izbor rukohvata

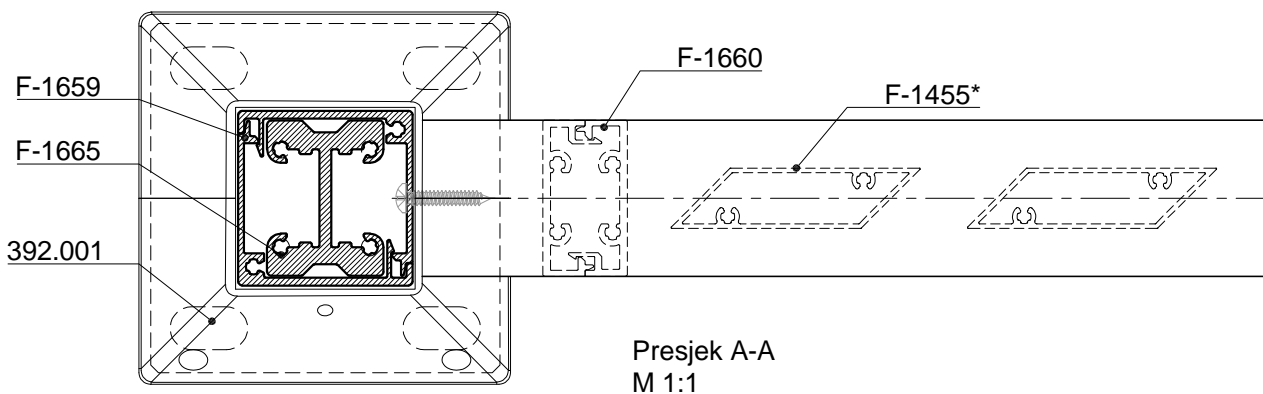

M 2:1

#### OF-80 Tip G-45

#### 1. Profili koji se koriste u segmentu:

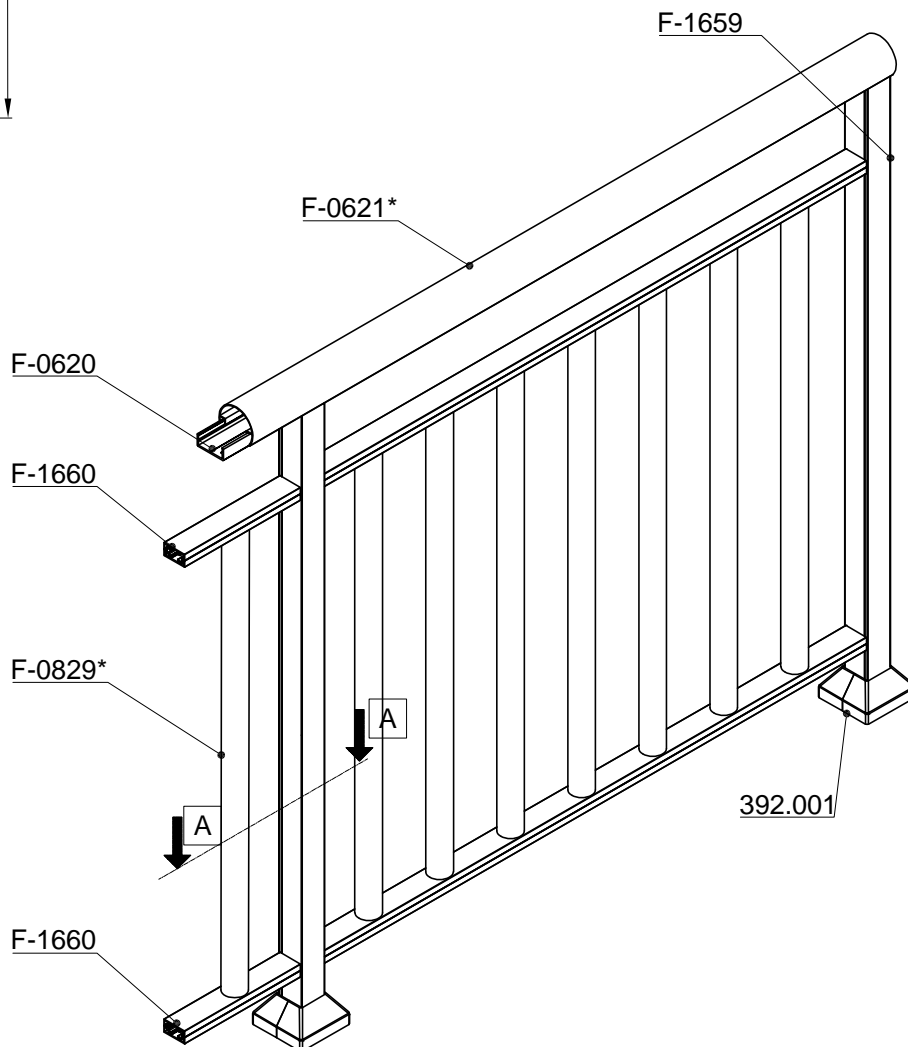
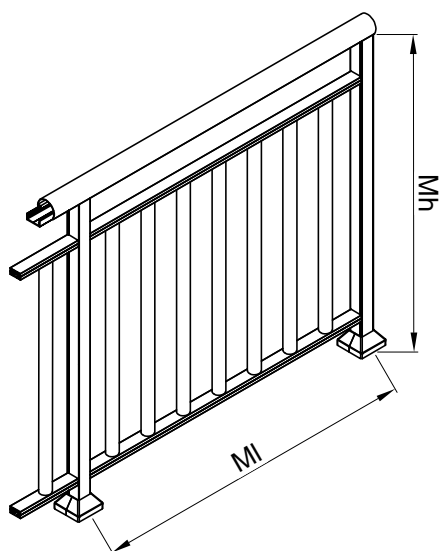

M 1:4

Profili segmenta	
F-1659 T=0.51kg/m	
F-1665 T=1.33kg/m	
F-1660 T=0.43kg/m	
F-0621 T=0.83kg/m	*
F-0620 T=0.60kg/m	
F-0829 T=0.30kg/m	*
OG-111 T=0.44kg/m	*

- \* - mogućnost većeg izbora profila  
 -str.br. 709.09.048 gornji dio segmenta  
 -str.br.709.09.043 donji dio segmenta  
 -str.br.709.09.051 izbor rukohvata

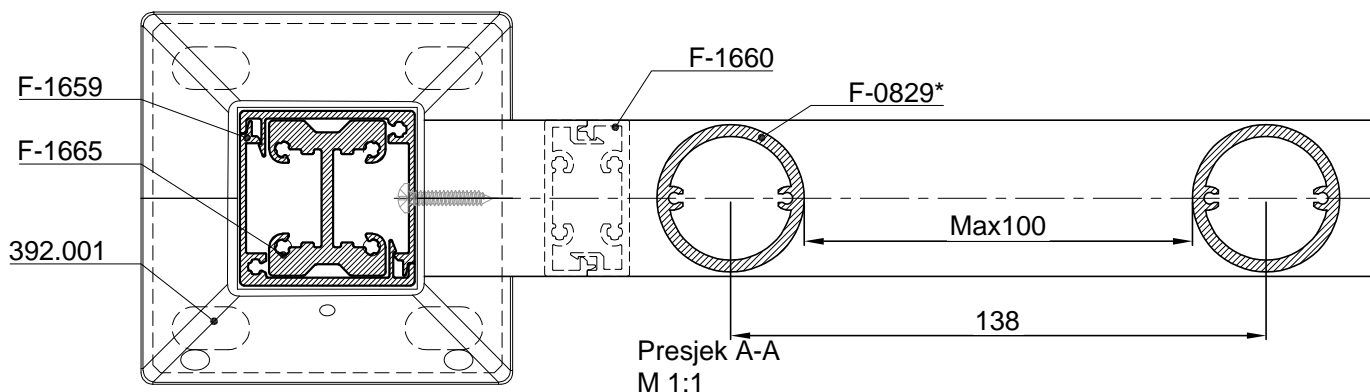

M 2:1

#### OF-80 Tip H-45

#### 1. Profili koji se koriste u segmentu:

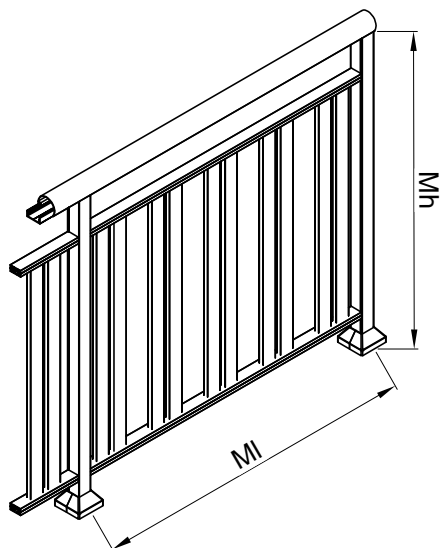

M 1:4

Profili segmenta	
F-1659 T=0.51kg/m	
F-1665 T=1.33kg/m	
F-1660 T=0.43kg/m	
F-0621 T=0.83kg/m	
F-0620 T=0.60kg/m	
F-1541 T=0.61kg/m	

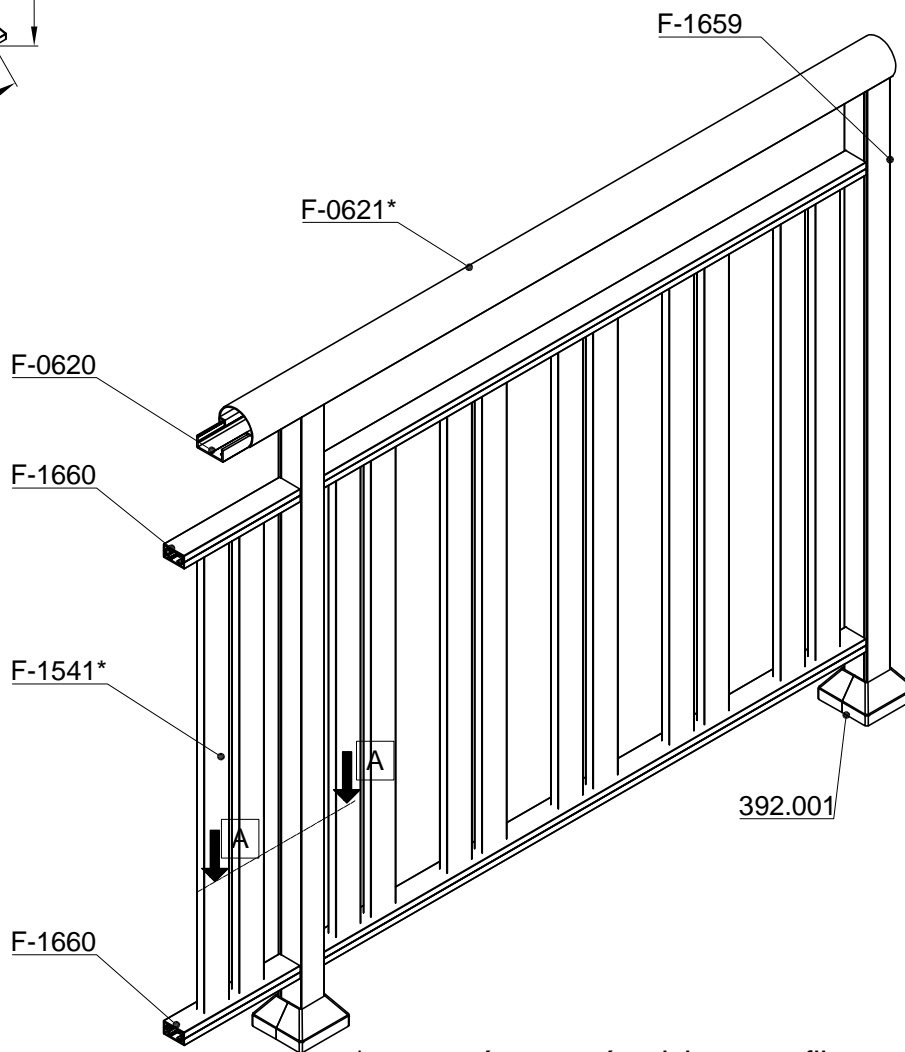

- \* - mogućnost većeg izbora profila
- str.br. 709.09.048 gornji dio segmenta
- str.br.709.09.043 donji dio segmenta
- str.br.709.09.051 izbor rukohvata

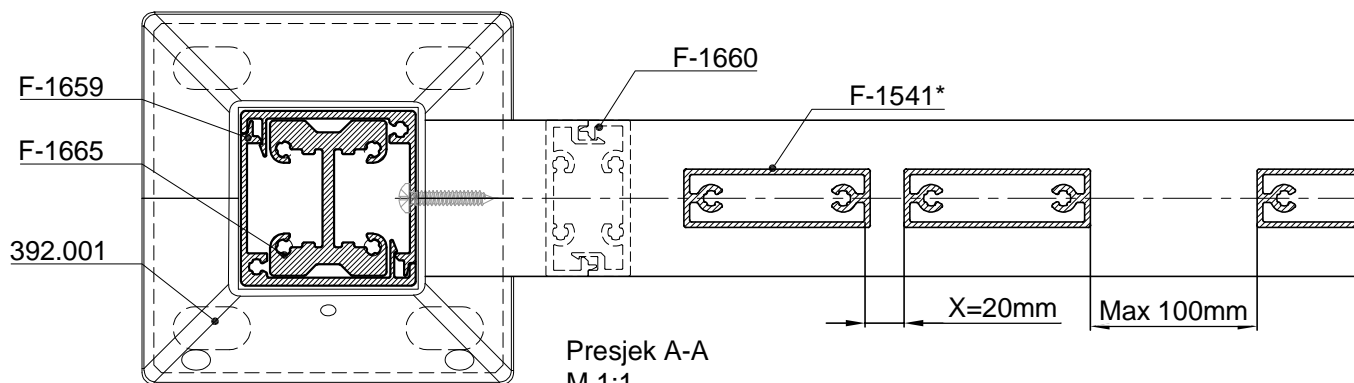

X-preporučeni razmak

M 2:1

#### OF-80 Tip I-45

#### 1. Profili koji se koriste u segmentu:

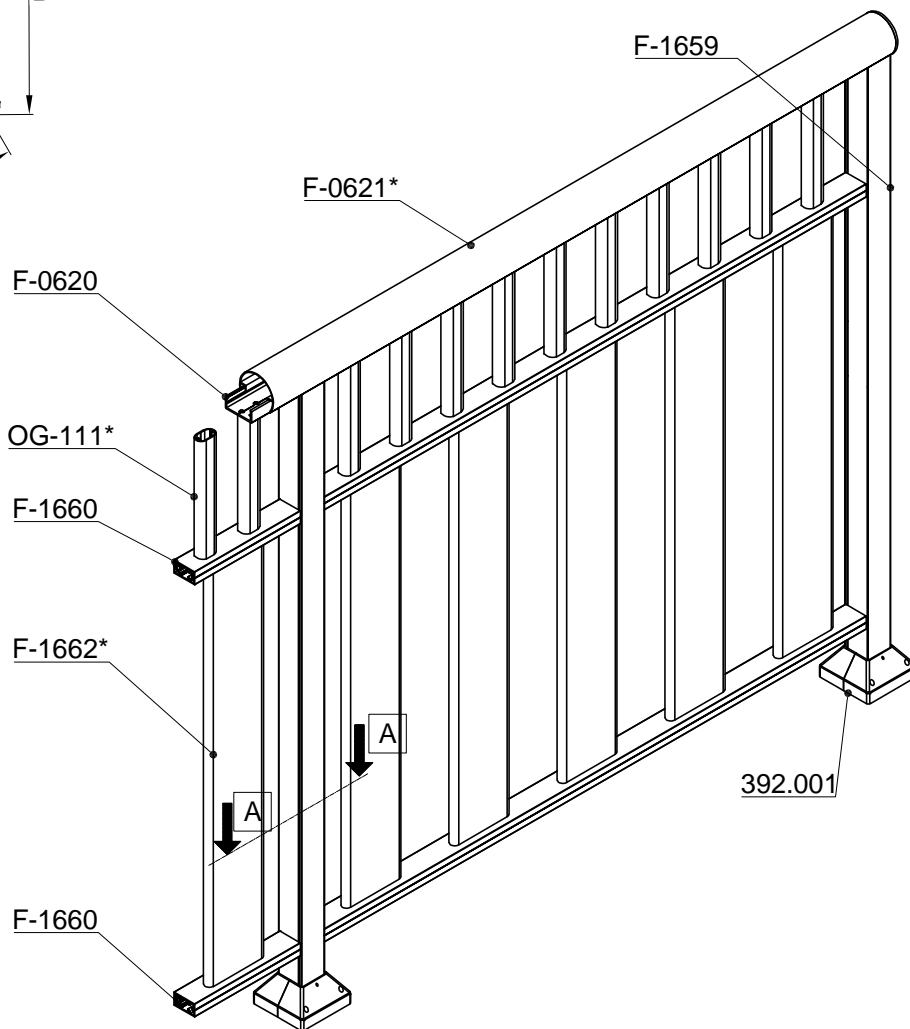
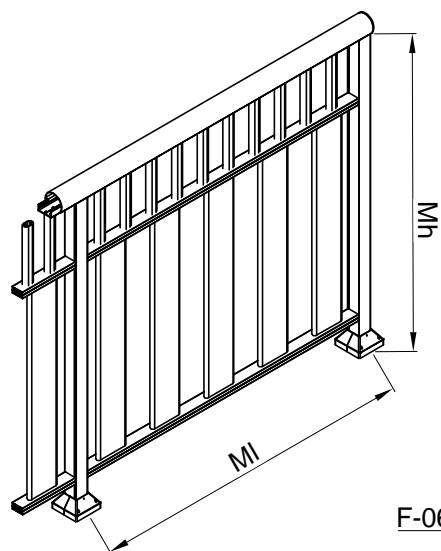

M 1:4

Profili segmenta	
F-1659 T=0.51kg/m	
F-1665 T=1.33kg/m	
F-1660 T=0.43kg/m	
F-0621 T=0.83kg/m	
F-0620 T=0.60kg/m	
F-1662 T=0.83kg/m	
OG-111 T=0.44kg/m	

- \* - mogućnost većeg izbora profila
- str.br. 709.09.048 gornji dio segmenta
- str.br.709.09.043 donji dio segmenta
- str.br.709.09.051 izbor rukohvata

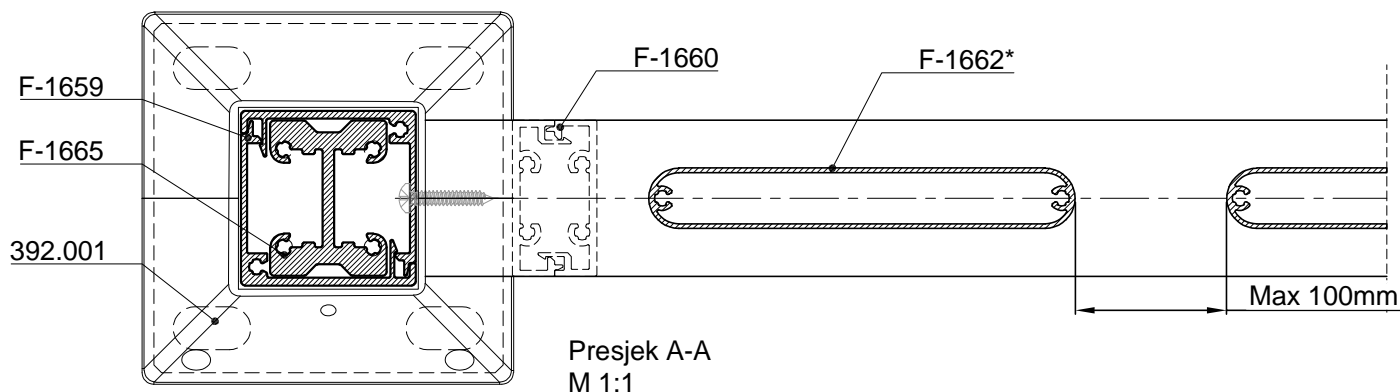

M 2:1

#### OF-80 Tip J-45

#### 1. Profili koji se koriste u segmentu:

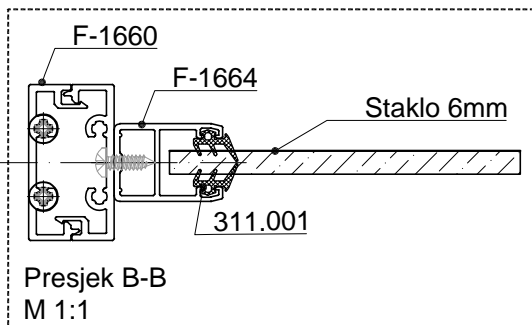
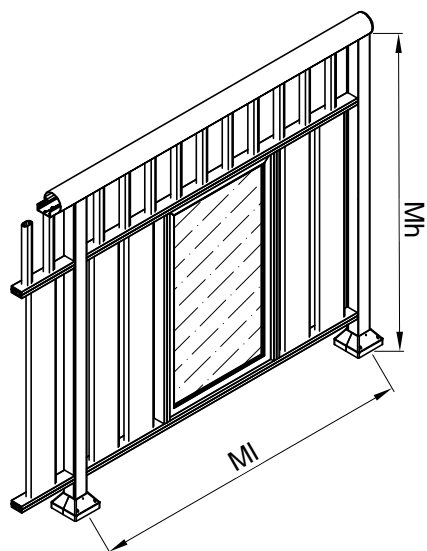

M 1:4

Profili segmenta	
F-1659 T=0.51kg/m	
F-1665 T=1.33kg/m	
F-1660 T=0.43kg/m	
F-0621 T=0.83kg/m	
F-0620 T=0.60kg/m	
F-1662 T=0.83kg/m	
F-1664 T=0.38kg/m	
OG-111 T=0.44kg/m	

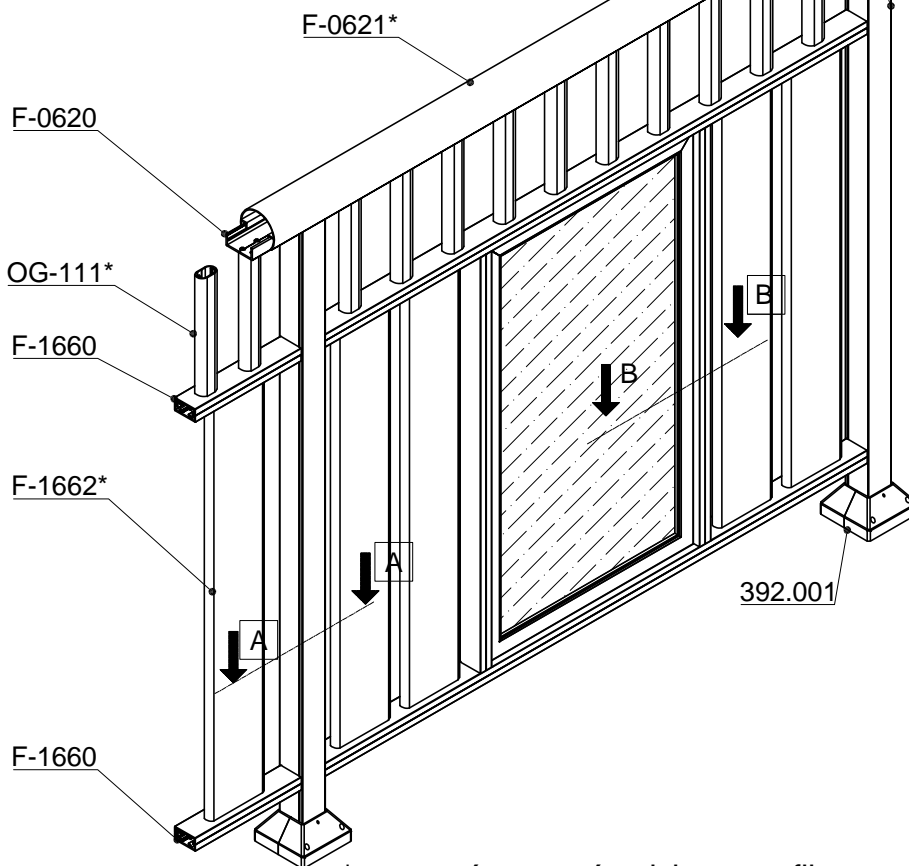

- \* - mogućnost većeg izbora profila
- str.br. 709.09.048 gornji dio segmenta
- str.br.709.09.043 donji dio segmenta
- str.br.709.09.051 izbor rukohvata

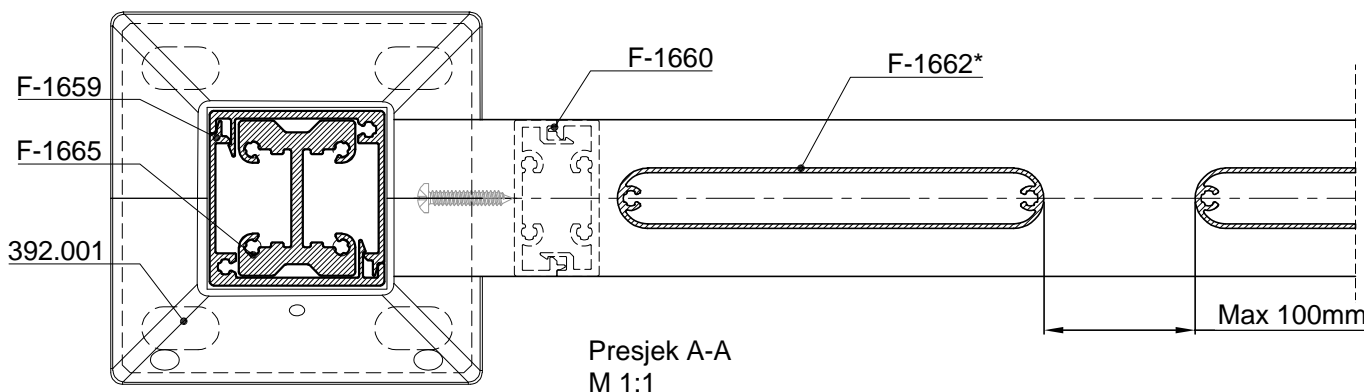

M 2:1

#### OF-80 Tip K-45

#### 1. Profili koji se koriste u segmentu:

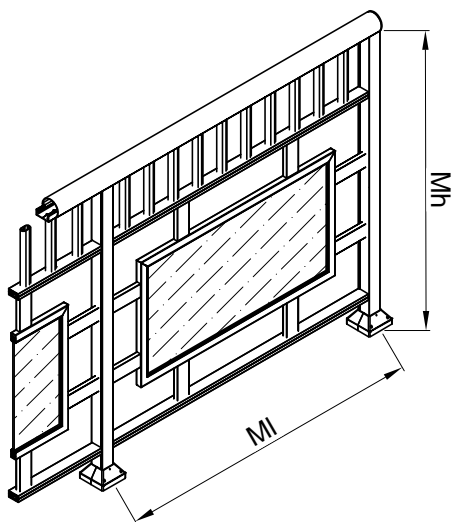

M 1:4

Profili segmenta	
F-1659 T=0.51kg/m	
F-1665 T=1.33kg/m	
F-1660 T=0.43kg/m	
F-0621 T=0.83kg/m	
F-0620 T=0.60kg/m	
F-1541 T=0.61kg/m	
F-1664 T=0.38kg/m	
OG-111 T=0.44kg/m	

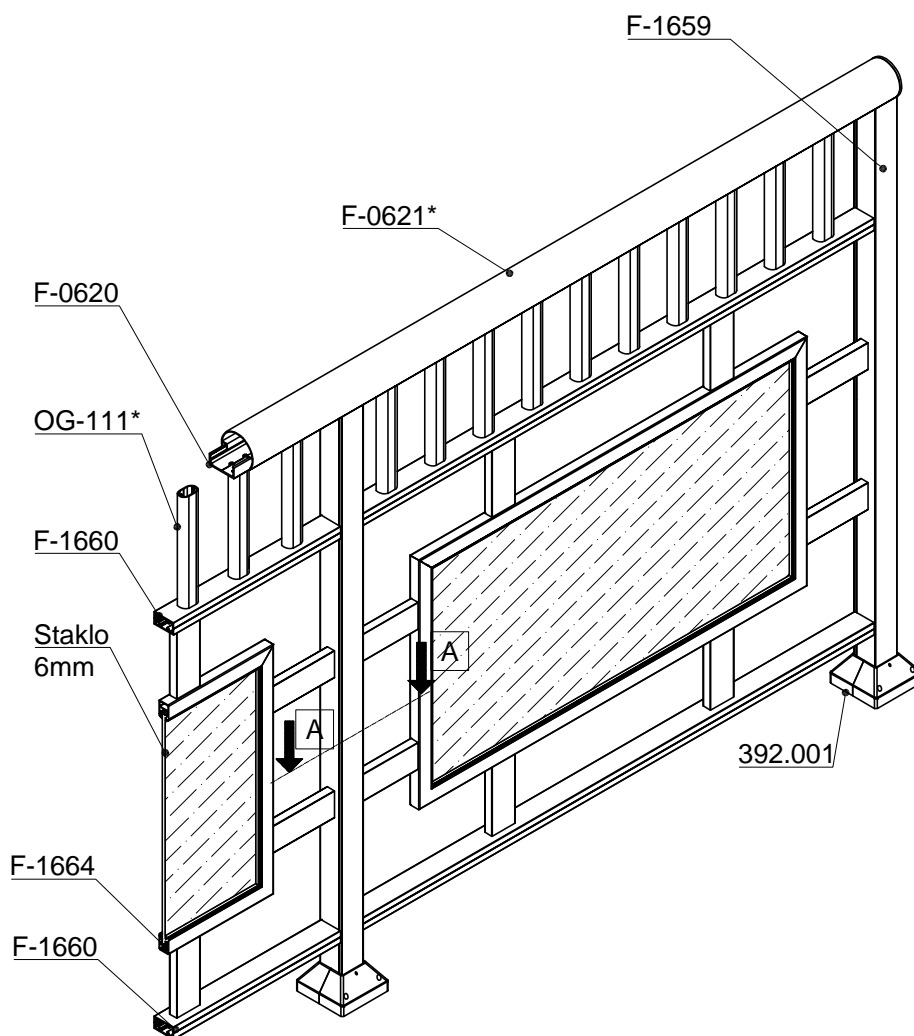

- \* - mogućnost većeg izbora profila
- str.br. 709.09.048 gornji dio segmenta
- str.br.709.09.051 izbor rukohvata

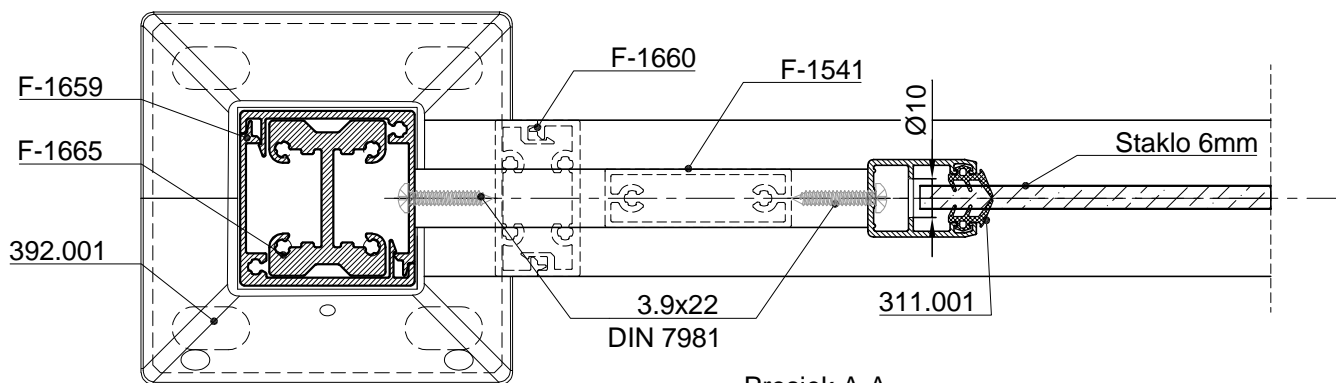

Presjek A-A  
M 1:1

M 2:1

#### OF-80 Tip L-45

#### 1. Profili koji se koriste u segmentu:

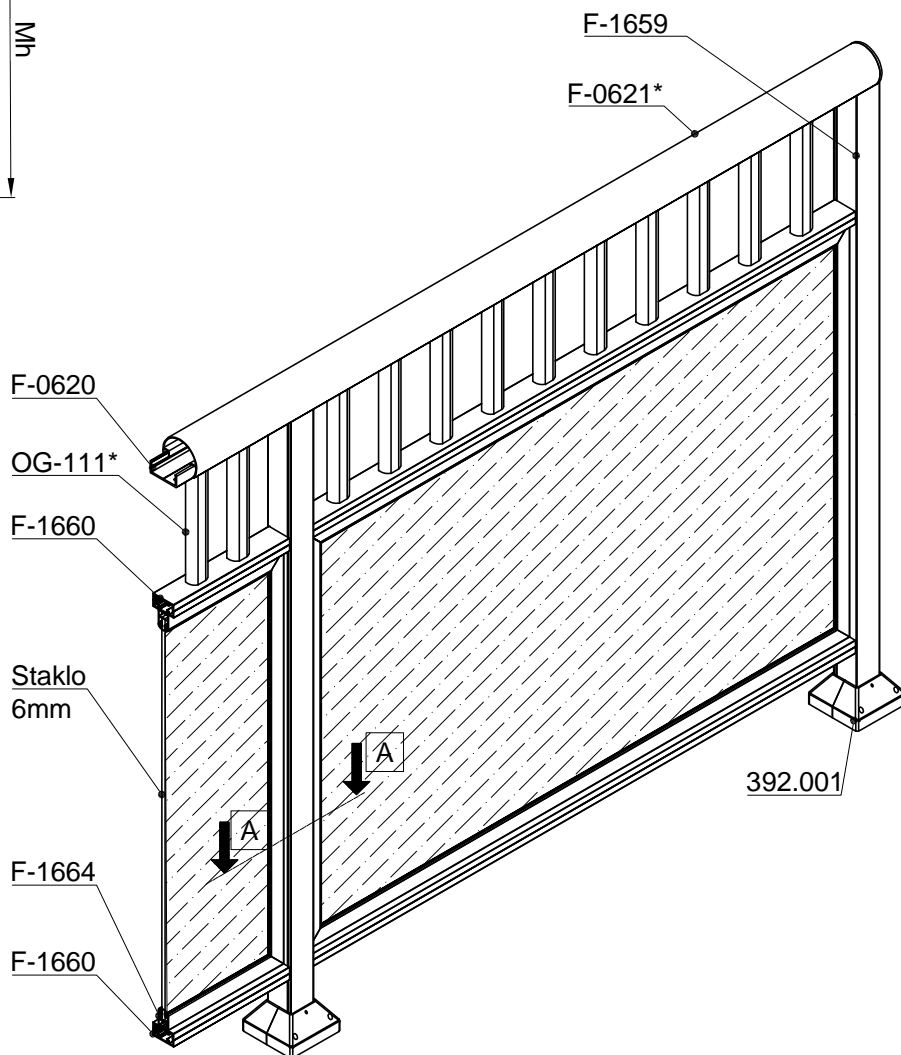
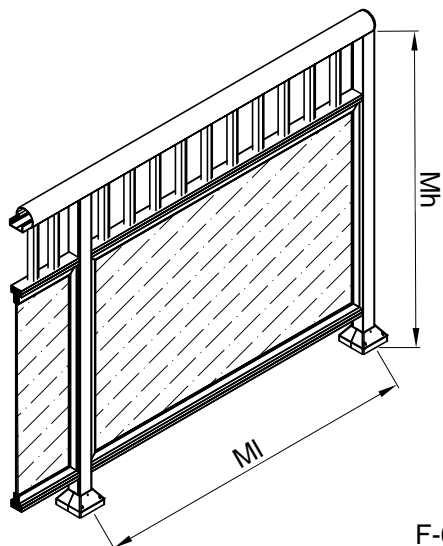

M 1:4

Profili segmenta	
F-1659 T=0.51kg/m	45
F-1665 T=1.33kg/m	40 / 30
F-1660 T=0.43kg/m	40.2
F-0621 T=0.83kg/m	66.2 *
F-0620 T=0.60kg/m	51
OG-111 T=0.44kg/m	35 / 20.2 *
F-1664 T=0.38kg/m	20

\* - mogućnost većeg izbora profila  
 -str.br. 710.09.048 gornji dio segmenta  
 -str.br.709.09.051 izbor rukohvata

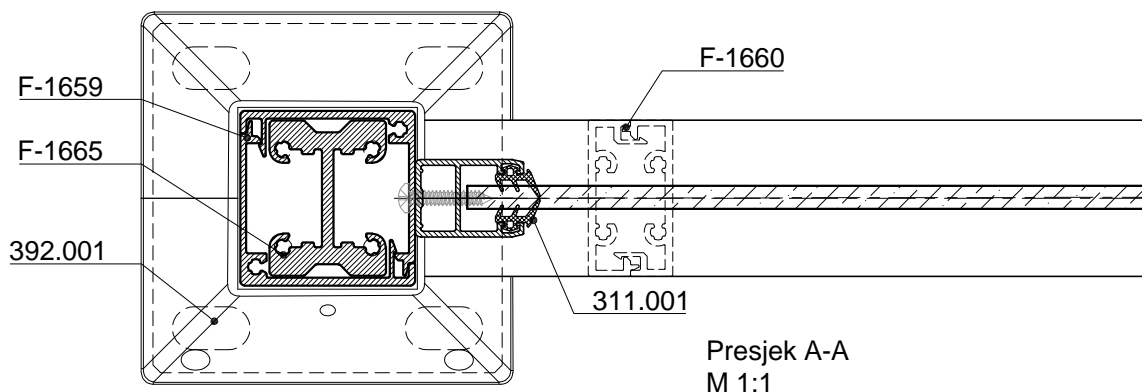

M 2:1

#### Prikaz montaže čepa ograde

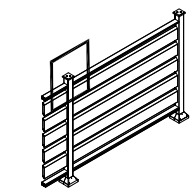

Tip: A-45-1

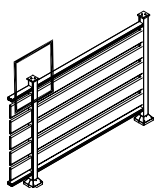

Tip: B-45-1

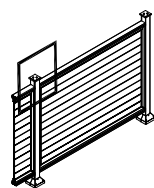

Tip: C-45-1

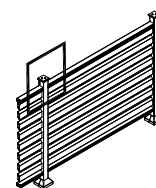

Tip: D-45-1

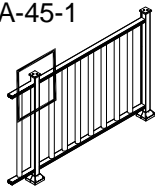

Tip: G-45-1

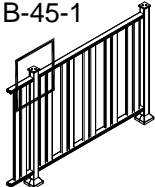

Tip: H-45-1

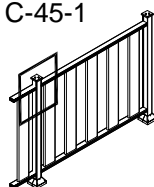

Tip: I-45-1

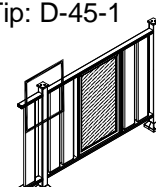

Tip: J-45-1

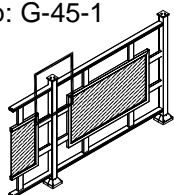

Tip: K-45-1

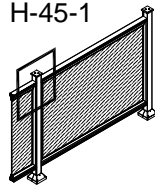

Tip: L-45-1

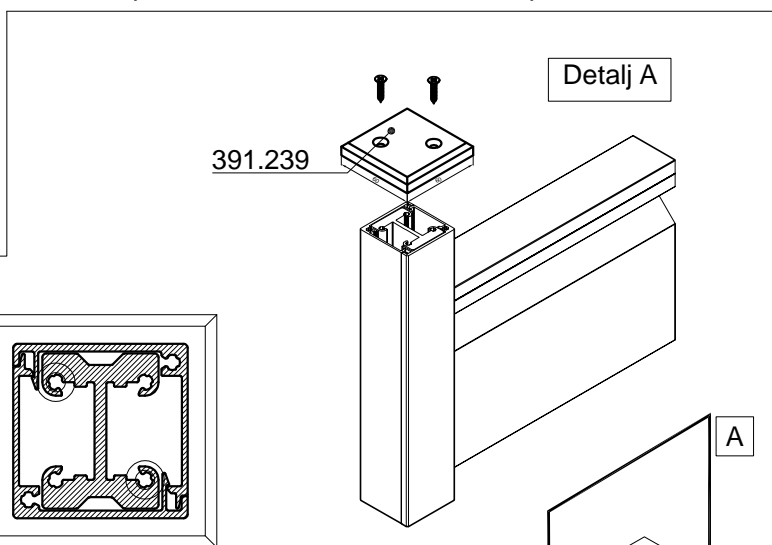

3,9x22  
DIN 7982

Profil stuba  
F-1659

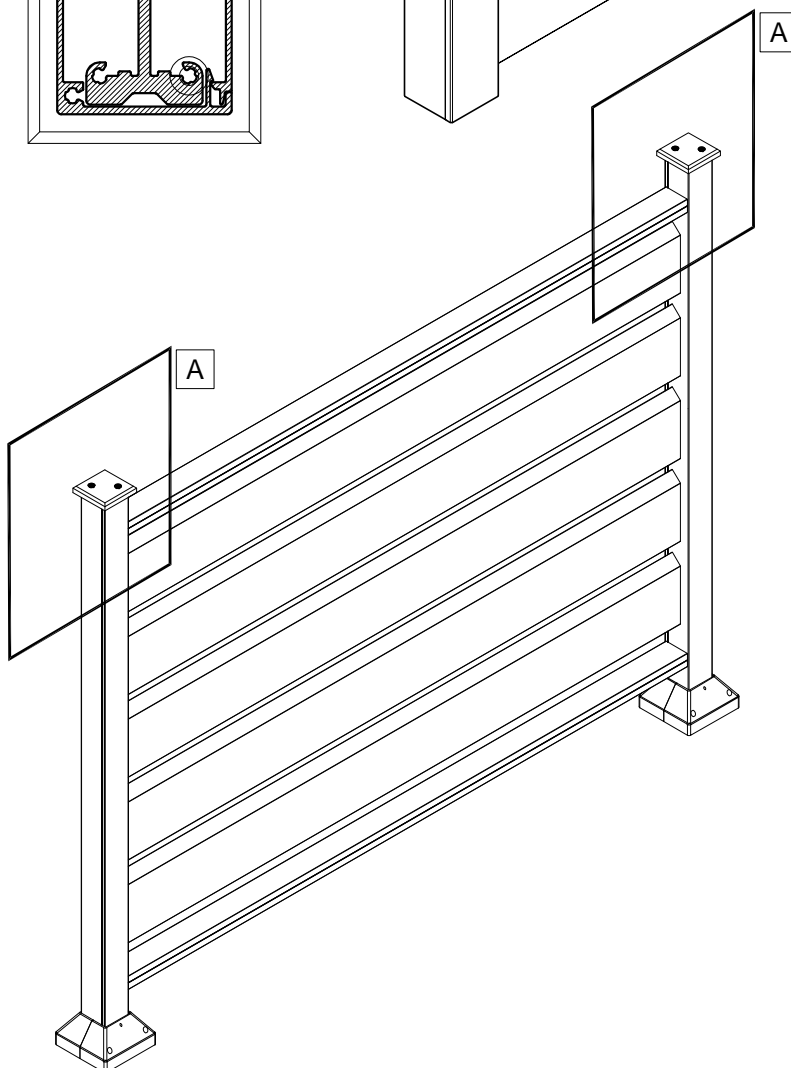
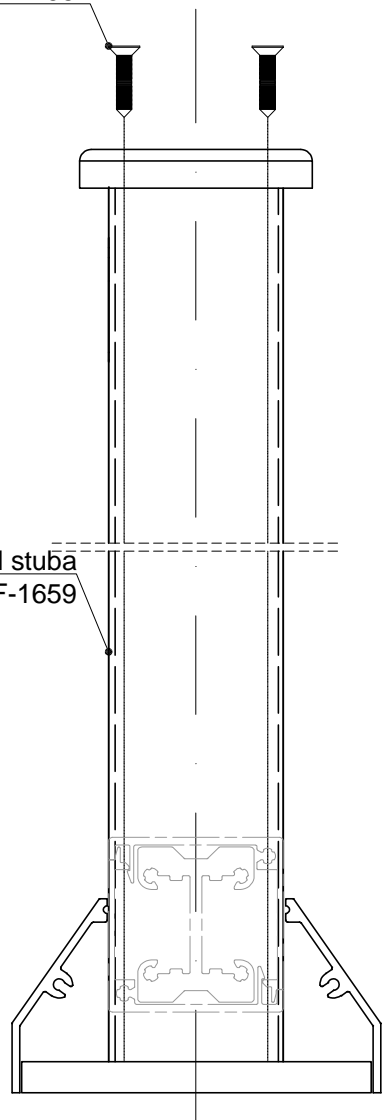

# Sheme

Tip: A-86 D

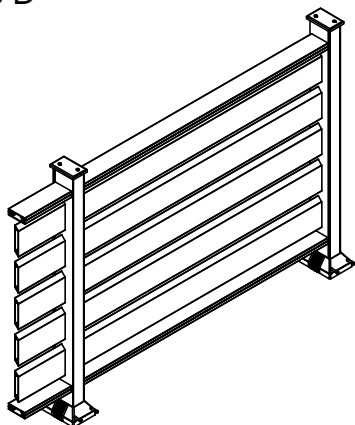

Tip: B-86 D

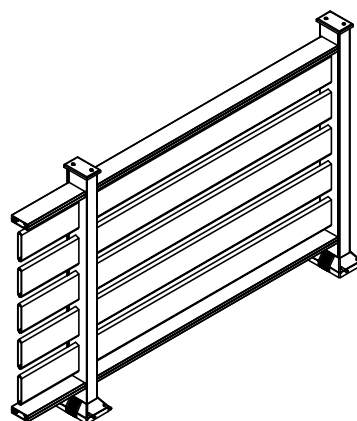

Tip: C-86 D

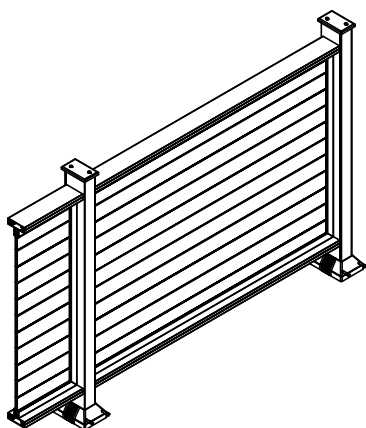

Tip: D-86 D

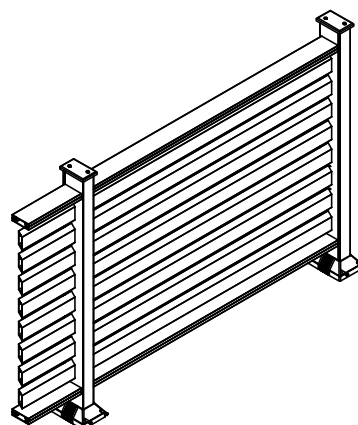

Tip: E-86 D

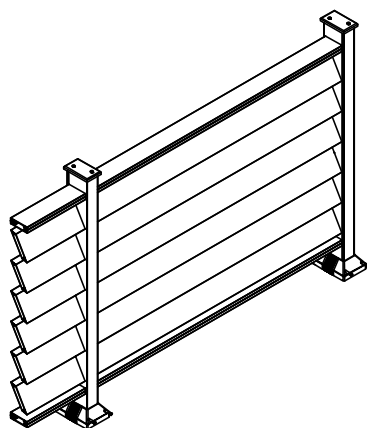

Tip: F-86 D

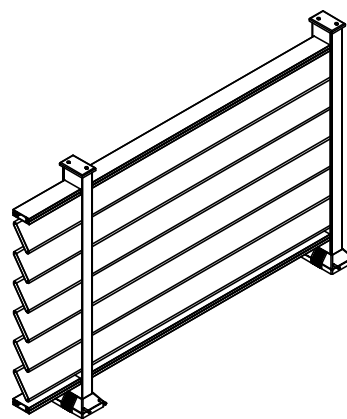

Tip: I-86 D

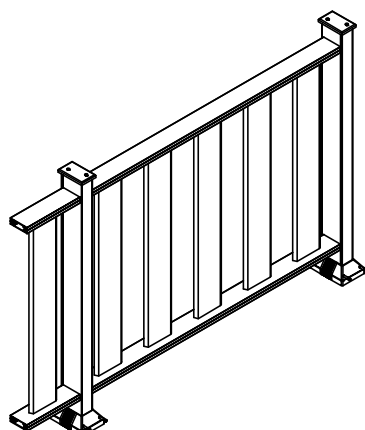

Tip: L-86 D

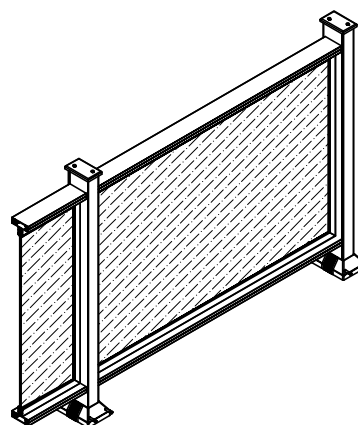

#### OF-80 Tip A-86 D

#### 1. Profili koji se koriste u segmentu:

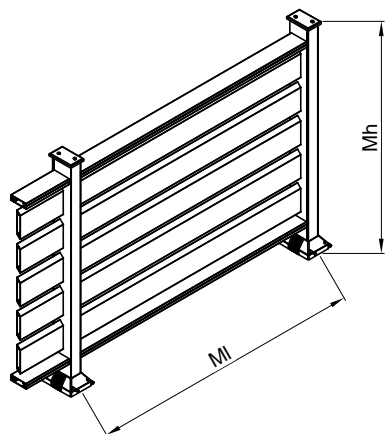

M 1:4

Profili segmenta	
F-1666 T=0.68kg/m	
F-1668 T=1.71kg/m	
F-1667 T=0.60kg/m	
F-1663 T=0.83kg/m	

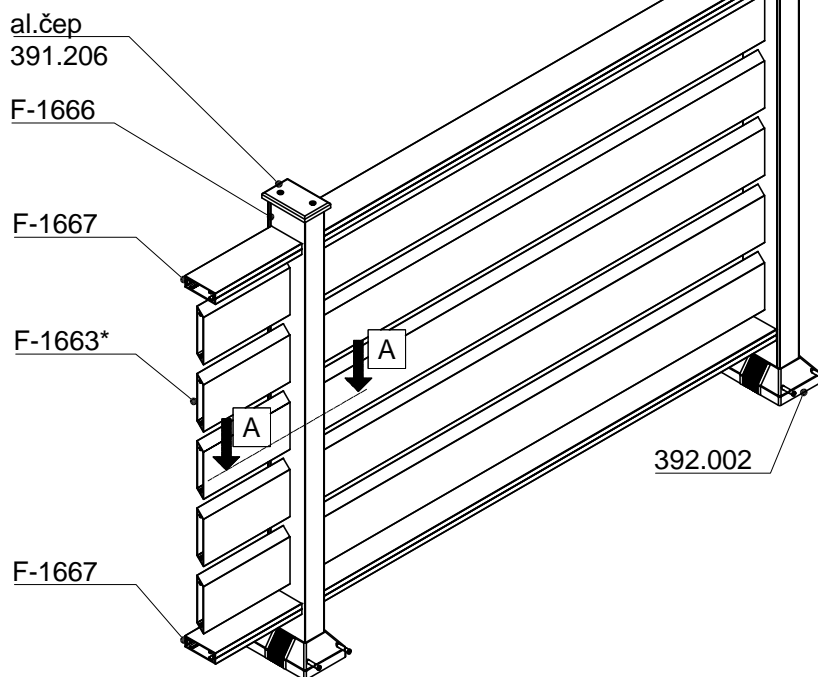

\* - mogućnost većeg izbora profila  
-str.br.709.09.042

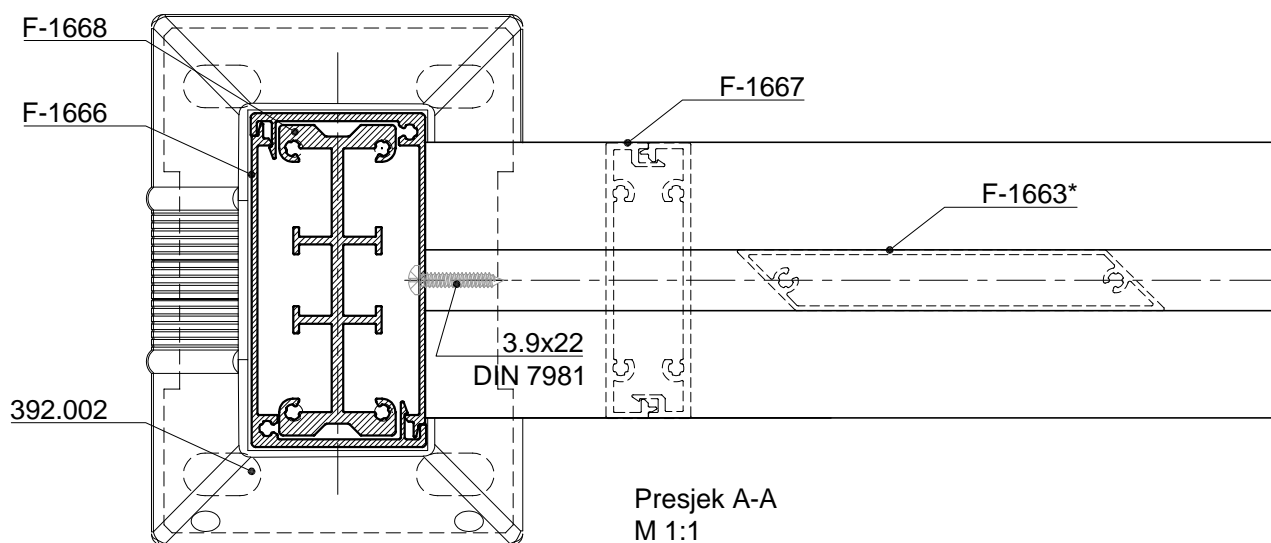

M 2:1

#### OF-80 Tip B-86 D

#### 1. Profili koji se koriste u segmentu:

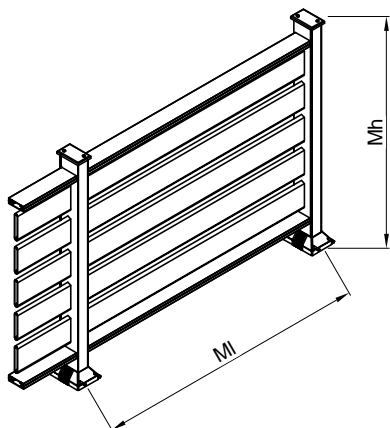

M 1:4

Profili segmenta	
F-1666 T=0.68kg/m	
F-1668 T=1.71kg/m	
F-1667 T=0.60kg/m	
F-1662 T=0.83kg/m	

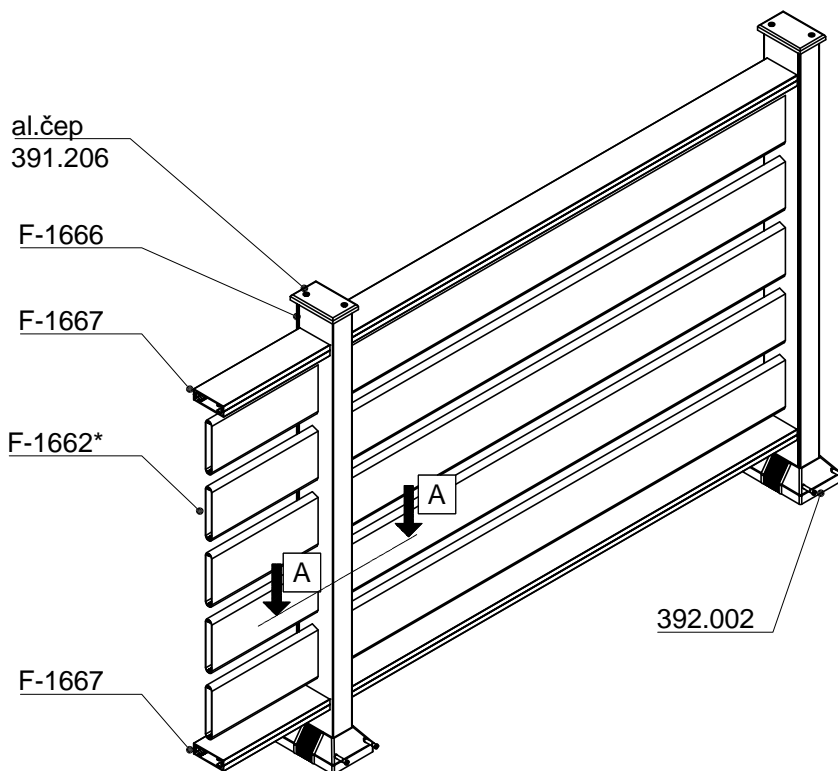

\* - mogućnost većeg izbora profila  
-str.br.709.09.042

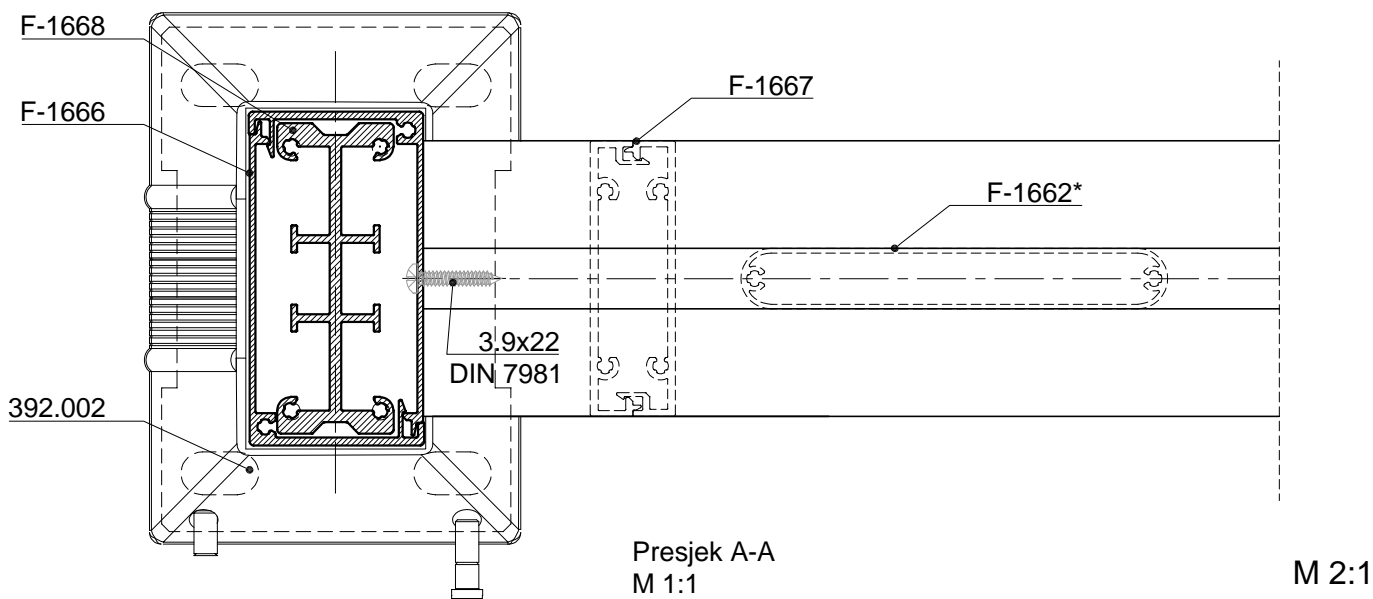

### OF-80 Tip C-86 D

#### 1. Profili koji se koriste u segmentu:

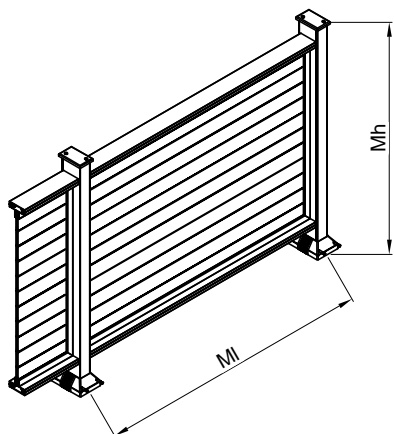

M 1:4

Profili segmenta	
F-1666 T=0.68kg/m	
F-1668 T=1.71kg/m	
F-1667 T=0.60kg/m	
F-1664 T=0.38kg/m	
F-0714 T=0.89kg/m	

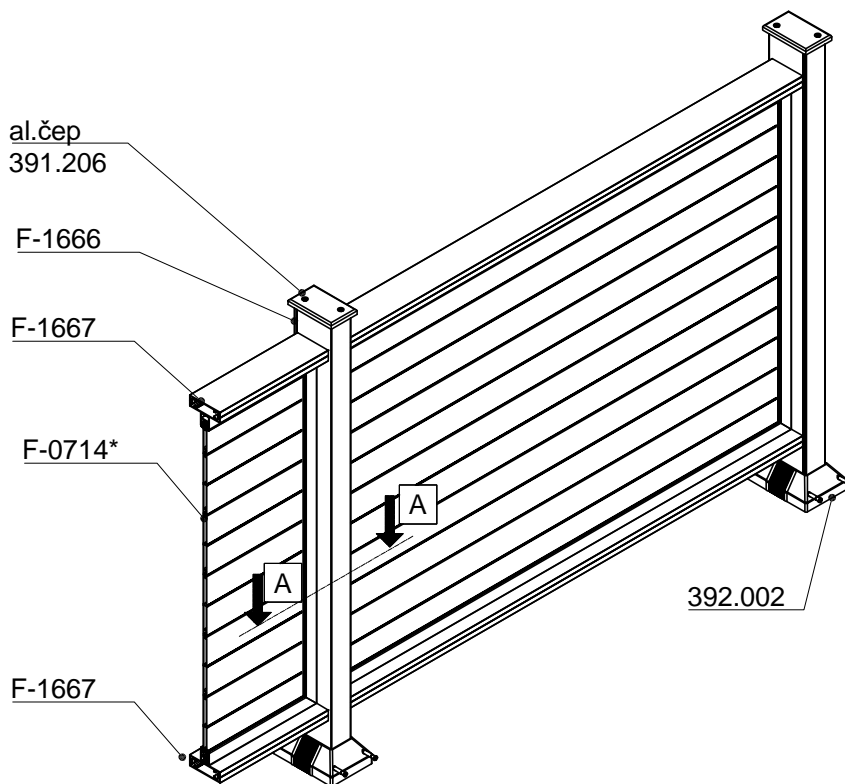

\* - mogućnost većeg izbora profila  
-str.br.709.09.042

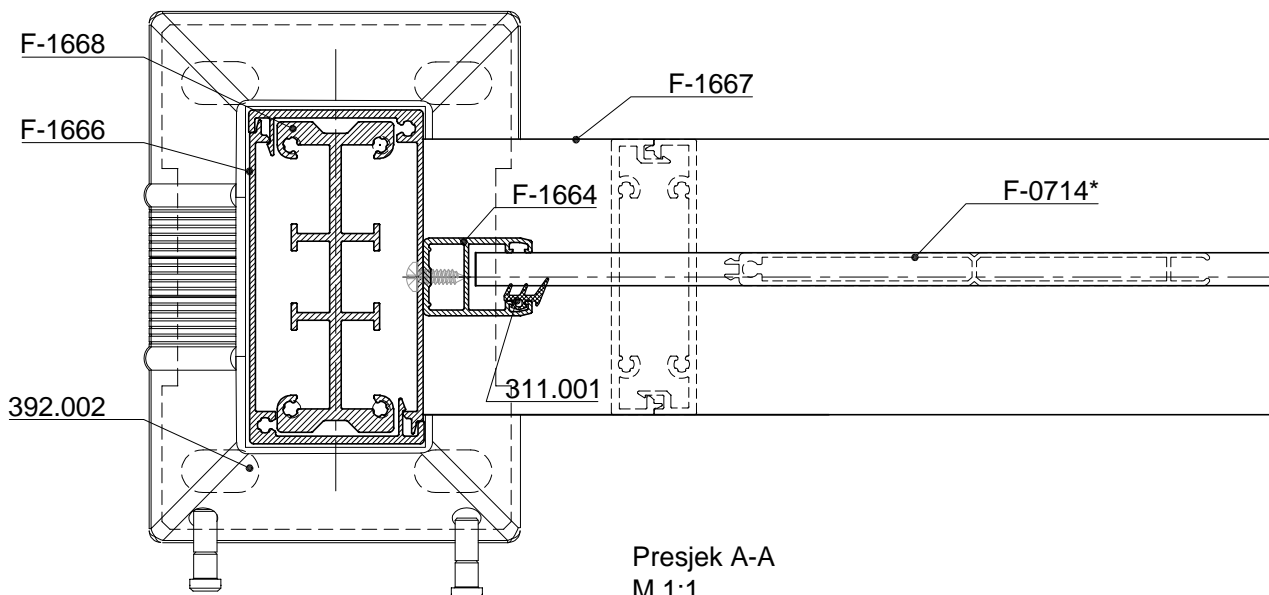

#### OF-80 Tip D-86 D

#### 1. Profili koji se koriste u segmentu:

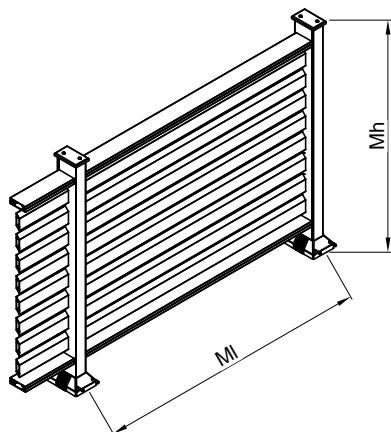

M 1:4

Profili segmenta	
F-1666 T=0.68kg/m	
F-1668 T=1.71kg/m	
F-1667 T=0.60kg/m	
F-1455 T=0.50kg/m	*

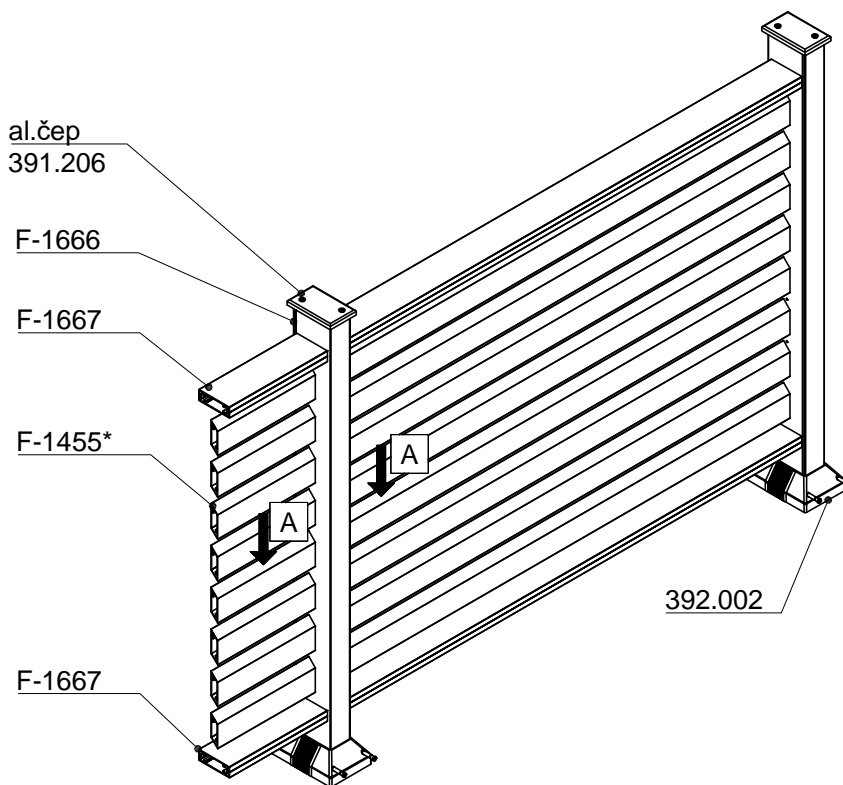

\* - mogućnost većeg izbora profila  
-str.br.709.09.042

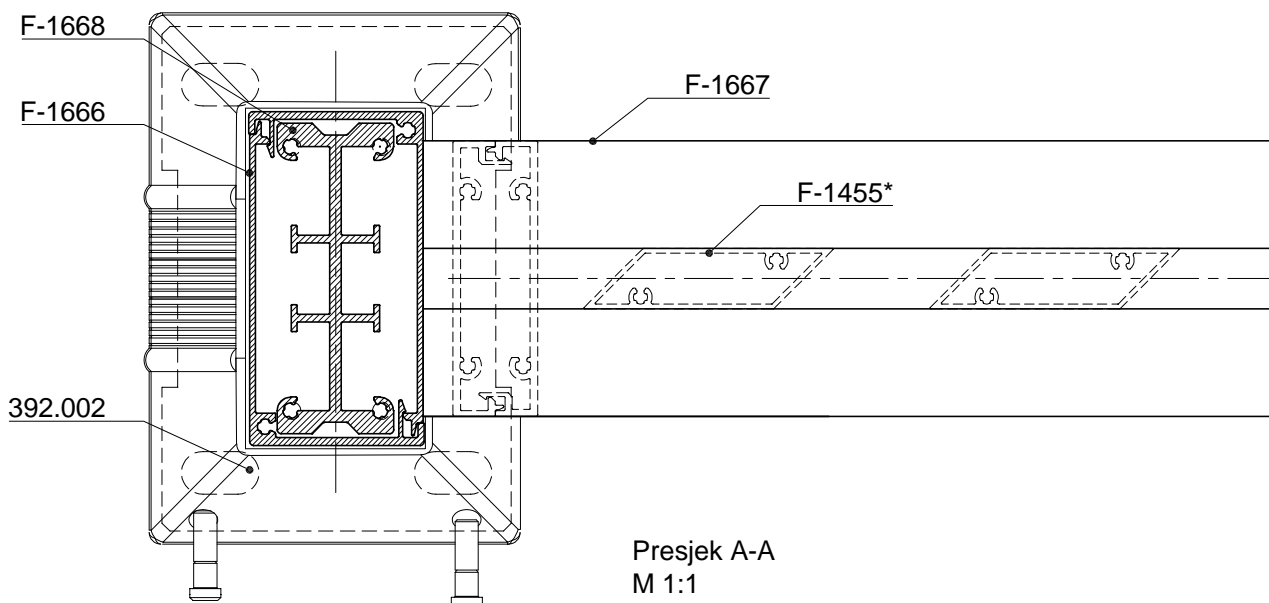

#### OF-80 Tip E-86 D

#### 1. Profili koji se koriste u segmentu:

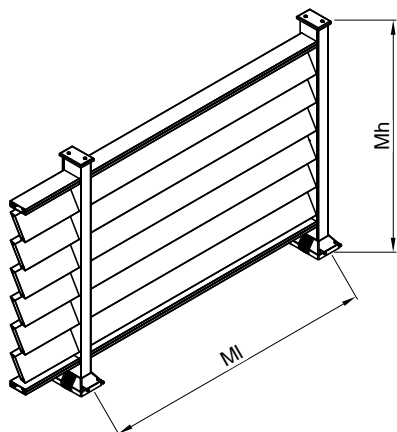

M 1:4

Profili segmenta	
F-1666 T=0.68kg/m	
F-1668 T=1.71kg/m	
F-1667 T=0.60kg/m	
F-1663 T=0.83kg/m	

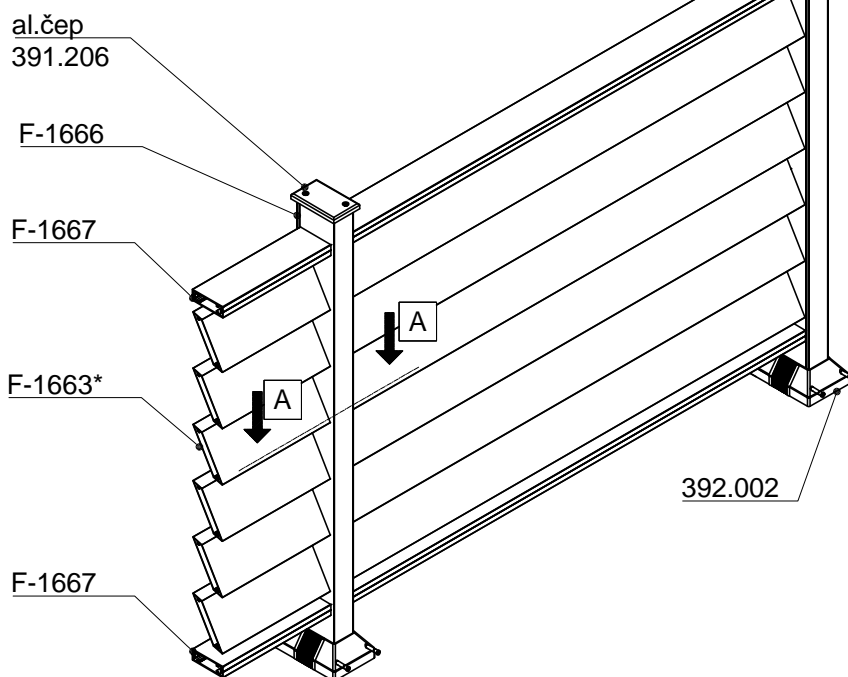

\* - mogućnost većeg izbora profila  
-str.br.709.09.042

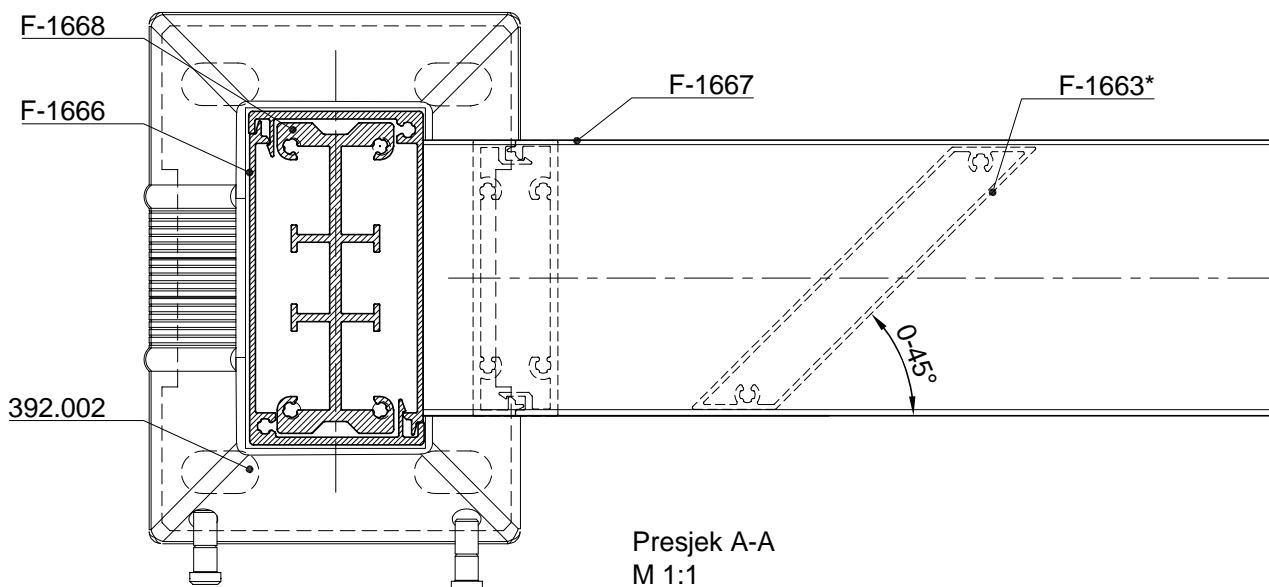

#### OF-80 Tip F-86 D

#### 1. Profili koji se koriste u segmentu:

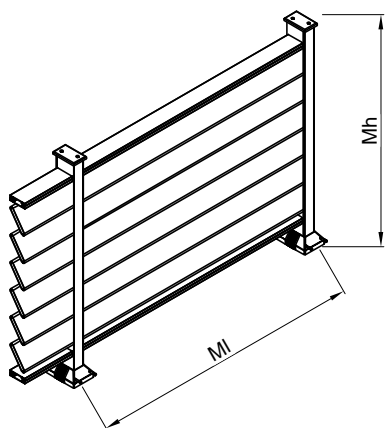

M 1:4

Profili segmenta	
F-1666 T=0.68kg/m	
F-1668 T=1.71kg/m	
F-1667 T=0.60kg/m	
F-1662 T=0.83kg/m	

al.čep  
391.206

F-1666

F-1667

F-1662\*

F-1667

392.002

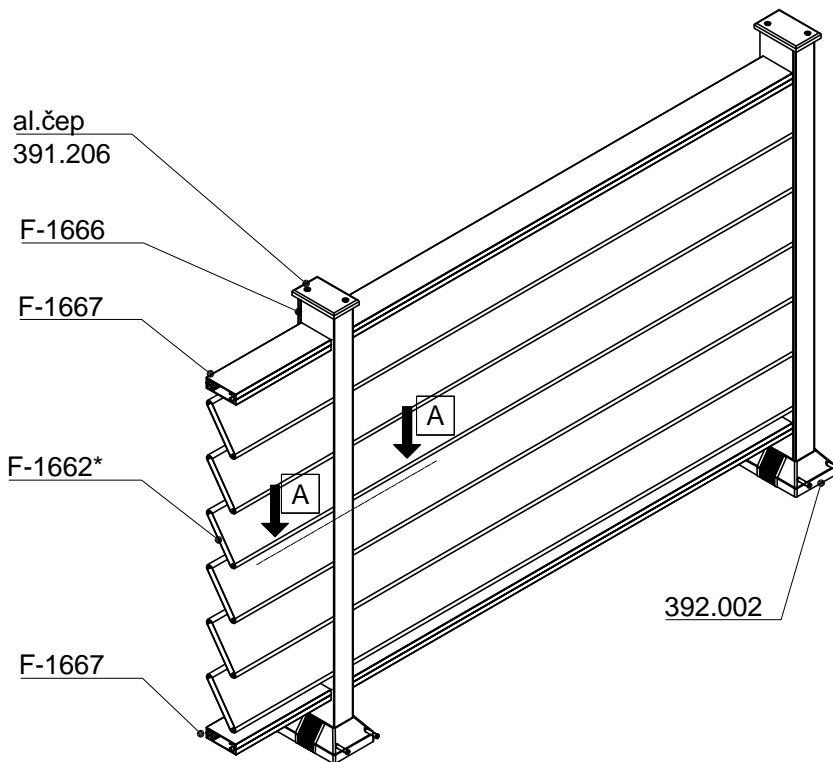

\* - mogućnost većeg izbora profila  
-str.br.709.09.042

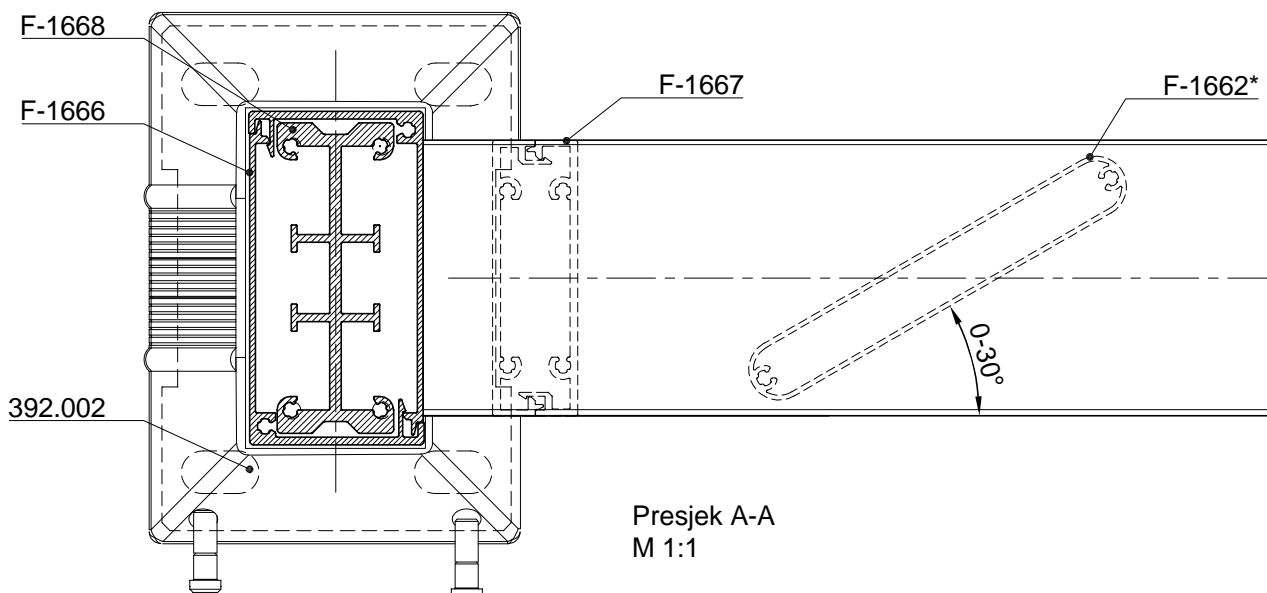

Presjek A-A  
M 1:1

M 2:1

#### OF-80 Tip I-86 D

#### 1. Profili koji se koriste u segmentu:

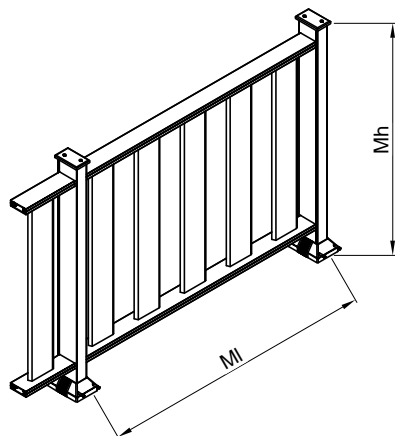

M 1:4

Profili segmenta	
F-1666 T=0.68kg/m	
F-1668 T=1.71kg/m	
F-1667 T=0.60kg/m	
F-1662 T=0.83kg/m	

al.čep  
391.206

F-1666

F-1667

F-1662\*

F-1667

392.002

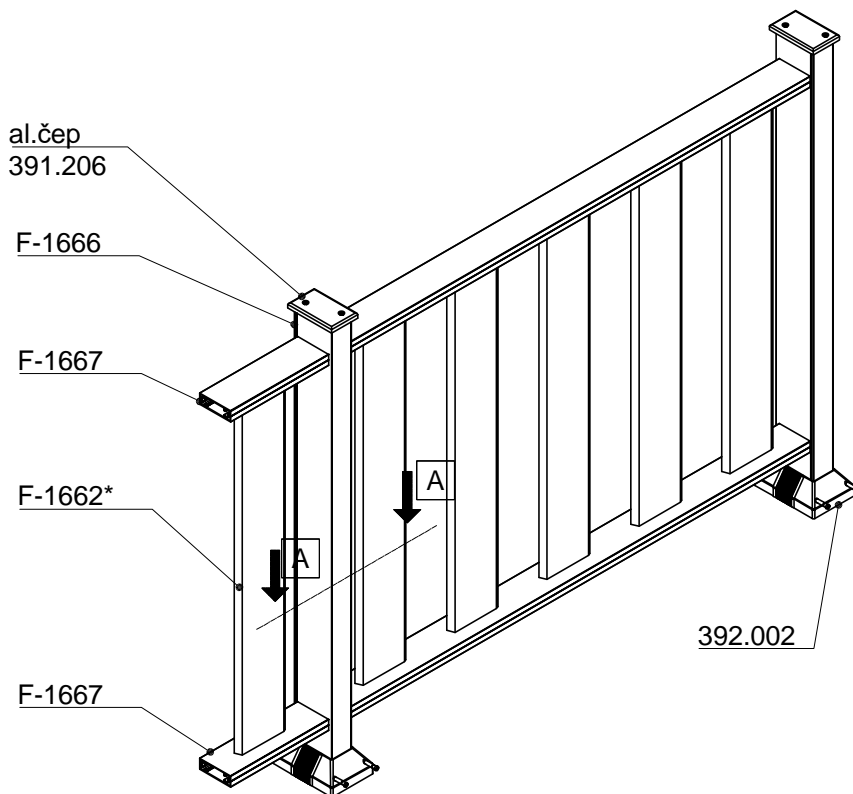

\* - mogućnost većeg izbora profila  
-str.br.709.09.042

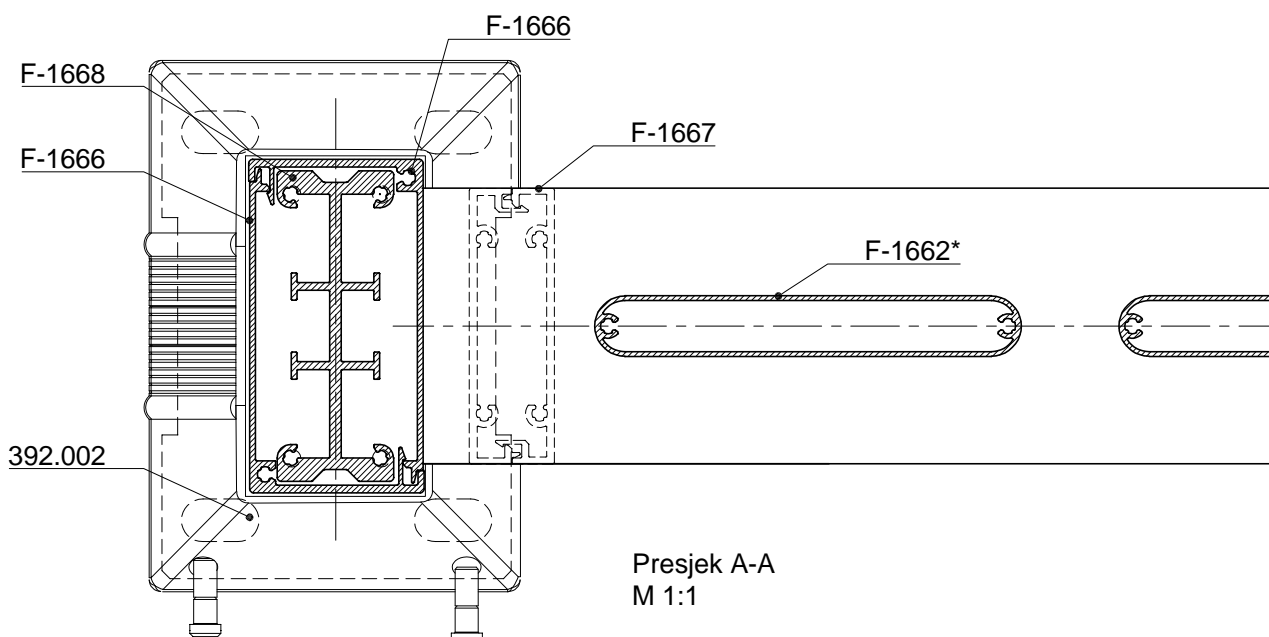

Presjek A-A  
M 1:1

M 2:1

### OF-80 Tip L-86 D

#### 1. Profili koji se koriste u segmentu:

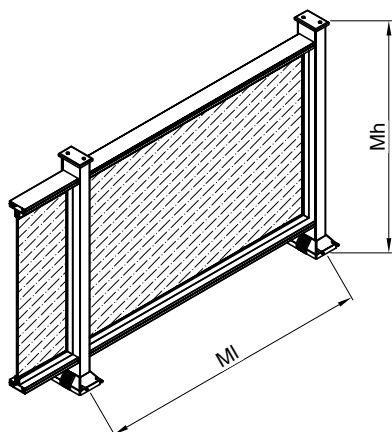

M 1:4

Profili segmenta	
F-1666 T=0.68kg/m	
F-1668 T=1.71kg/m	
F-1667 T=0.60kg/m	
F-1664 T=0.38kg/m	

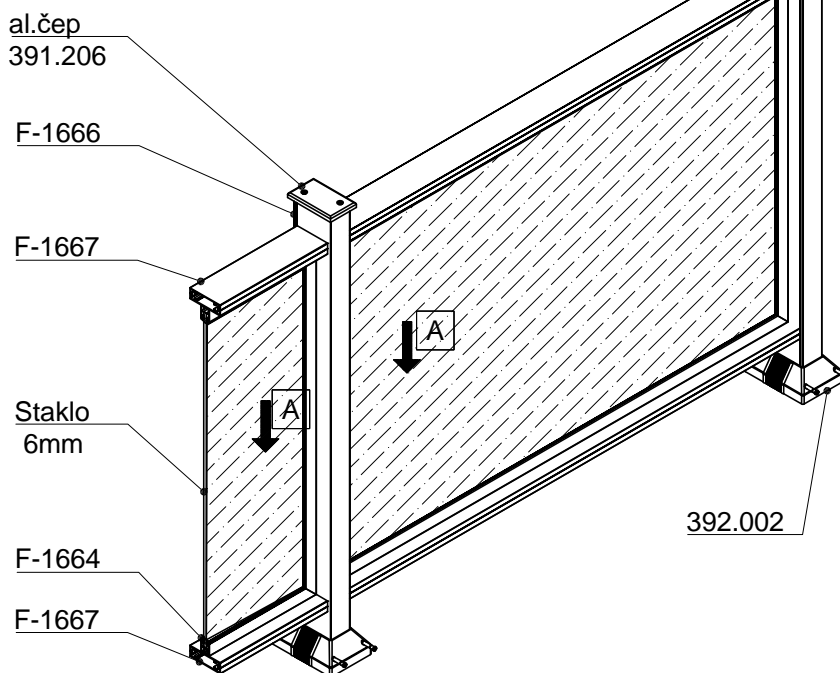



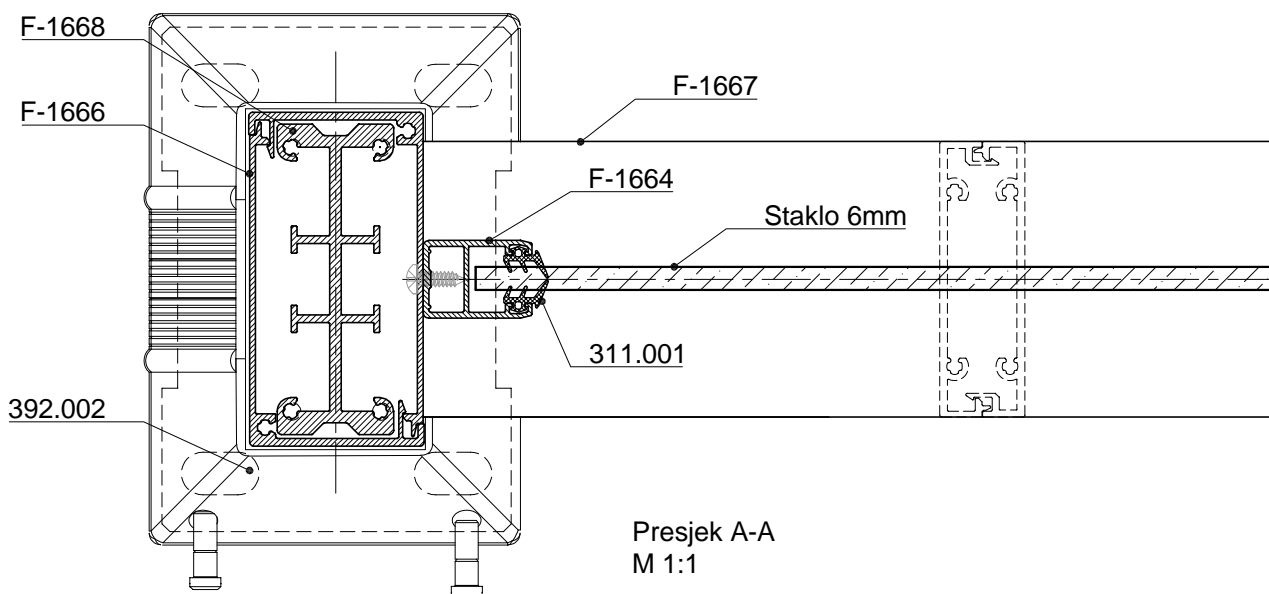







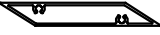
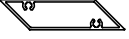



\* - mogućnost većeg izbora profila  
-str.br.709.09.042

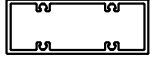

# Karakteristični presjeci

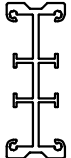
### Tabela 1 vijci za spajanje profila

M 1:4

PROFILI	vijci d*x l
 F-0829  F-1477  F-1455	3,5x22 DIN 7981 433.006
 F-1659  F-1660  F-1666  F-1667 <hr/>  F-1663  F-1690 <hr/>  F-1139  F-1541  F-1662	3,9 x22 DIN 7981 433.108
 OG-111  F-1665  F-1668	4,2x22 DIN 7981 433.031
 F-0356  F-0714	4,8x22 DIN 7981 433.044
 F-1664	3,9 x13 DIN 7981 433.016

#### Prikaz montaže donje prečke

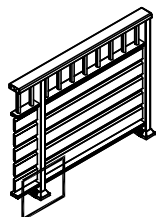

Tip: A

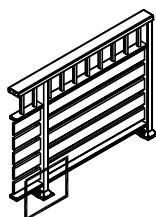

Tip: B

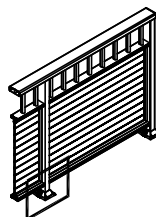

Tip: C

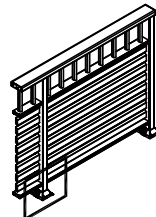

Tip: D

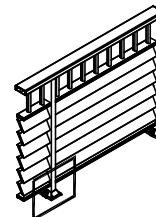

Tip: E

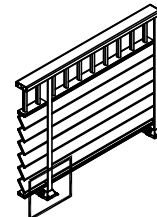

Tip: F

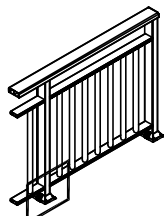

Tip: G

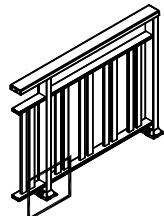

Tip: H

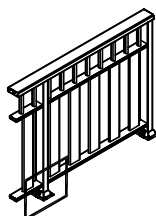

Tip: I

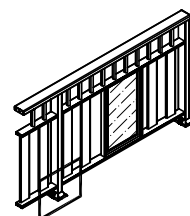

Tip: J

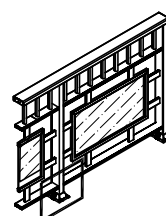

Tip: K

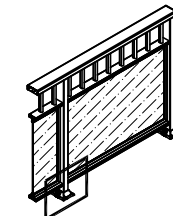

Tip: L

M 1:2

Mogući izbor profila

F-1660



F-1667

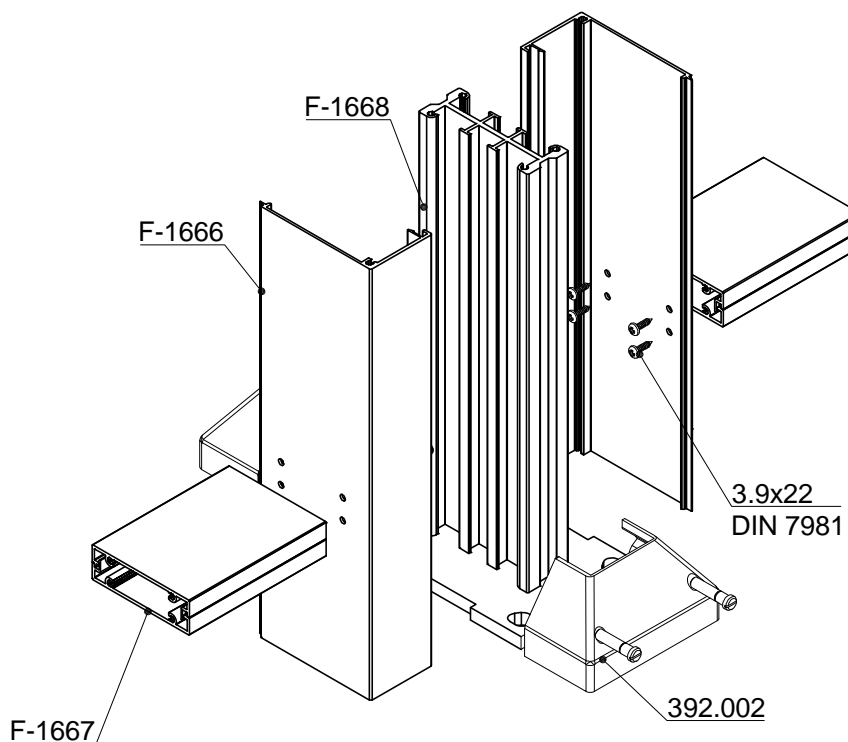

F-1660

F-1659

F-1665

F-1667

F-1666

F-1668

Stub 45x45

Stub 45x86

#### Prikaz montaže horizontalne ispune

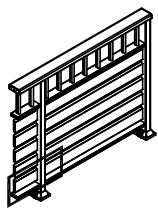

Tip: A

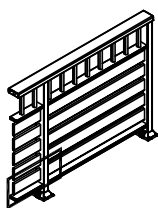

Tip: B

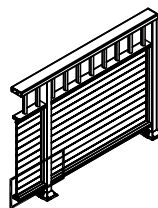

Tip: C

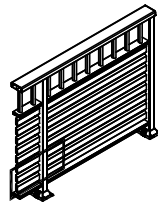

Tip: D

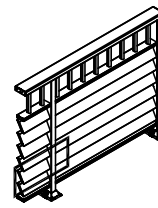

Tip: E

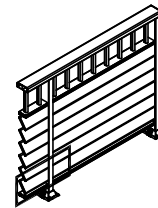

Tip: F

M 1:2

* -Mogući izbor profila	
F-1455	
F-1477	
F-1663	
F-1690	
F-1662	
F-1541	
F-0829	
F-0714	

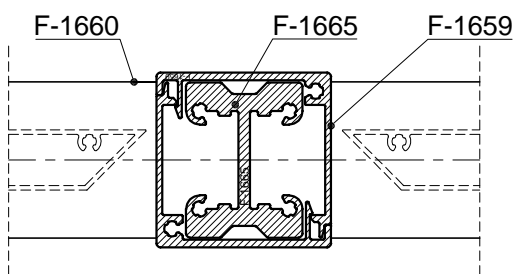
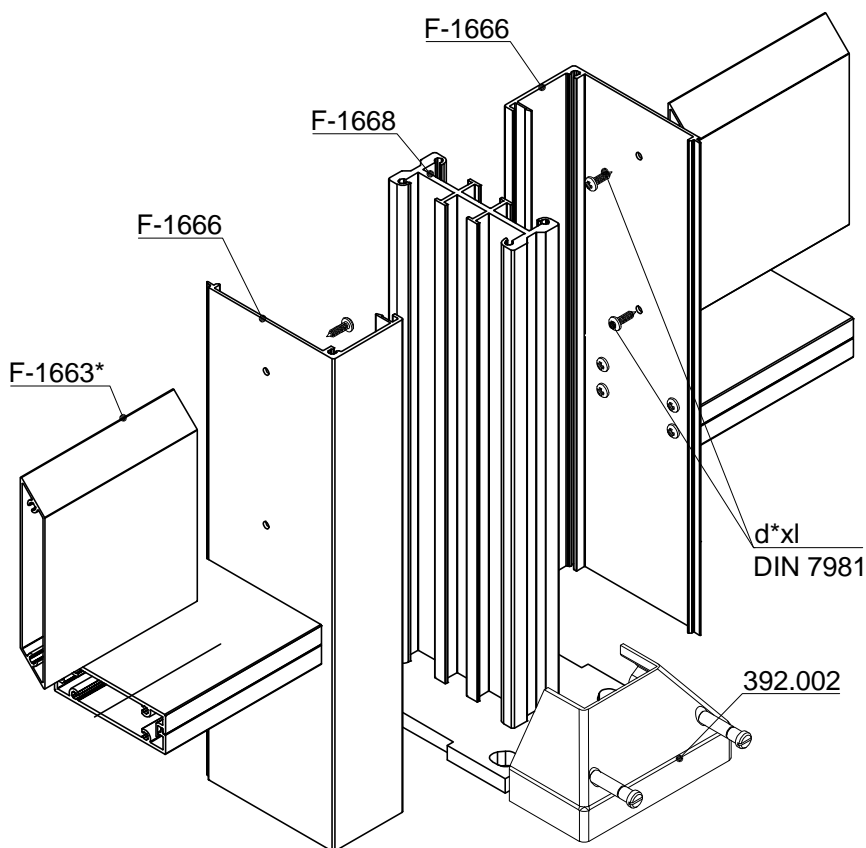

Stub 45x45

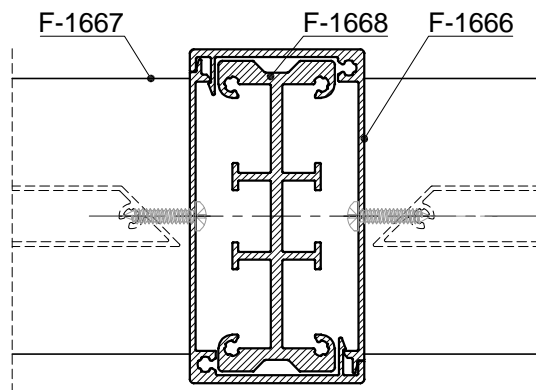

Stub 45x86

d\*x l DIN 7981 prečnik vijka prema tabeli 1

#### Prikaz montaže vertikalne ispune

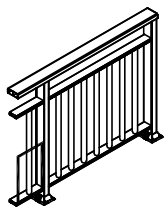

Tip: G

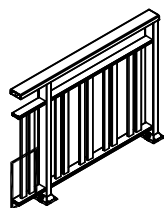

Tip: H

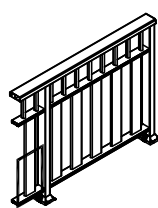

Tip: I

M 1:2

\*-Mogući izbor profila

F-1455	
F-1477	
F-1663	
F-1690	
F-1662	
F-1541	
F-0829	
OG-111	
F-0829	

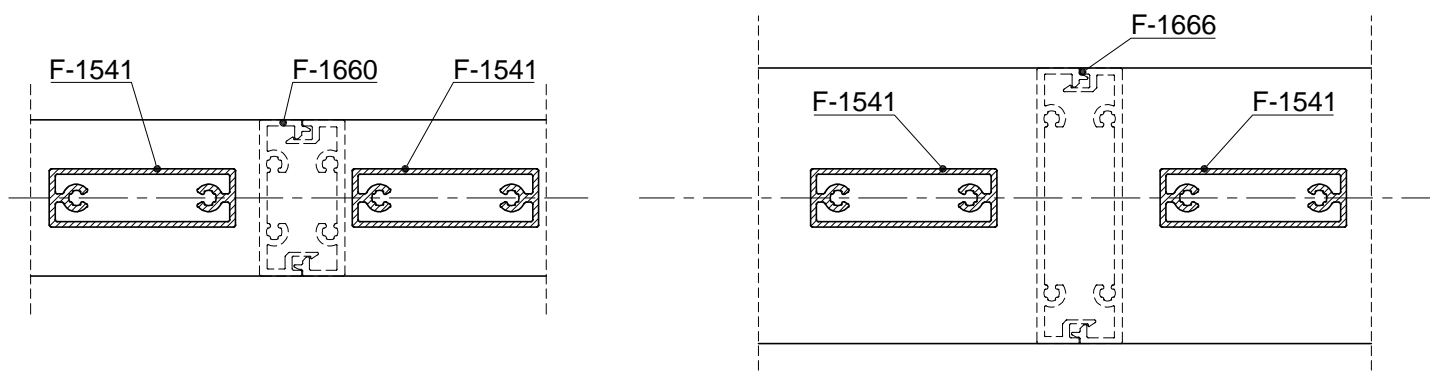
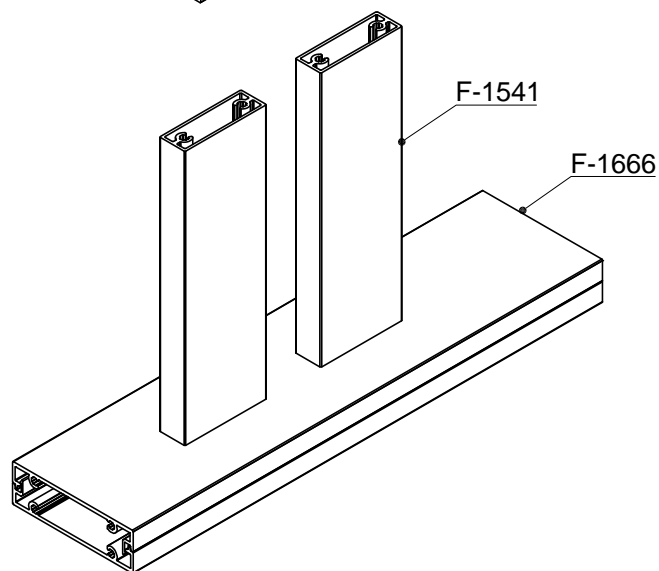
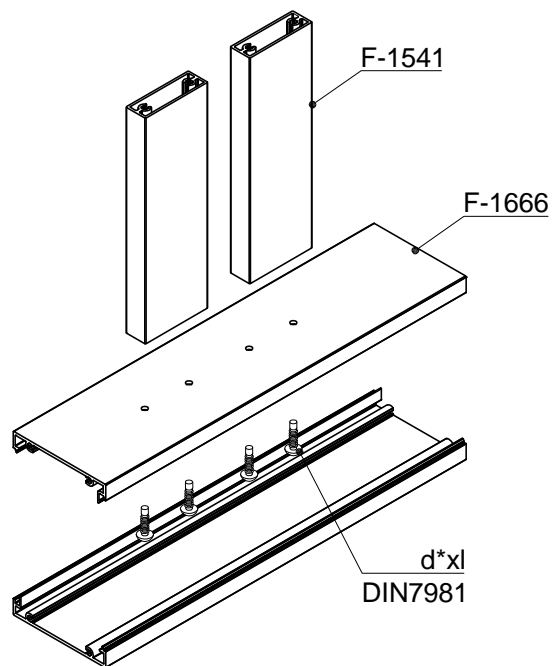

d\*x l DIN 7981 prečnik vijka prema tabeli 1

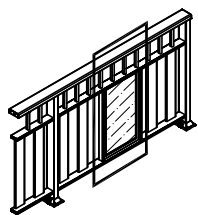

Tip: J

### Prikaz montaže vertikalnih ispuna sa staklom

1. Sklopiti ram F-1664 sa staklenom ispunom
2. Ram vezati s vertikalnim profilima F-1660
3. Takav sklop umetnuti između prečki F-1667 i pričvrstiti vijcima

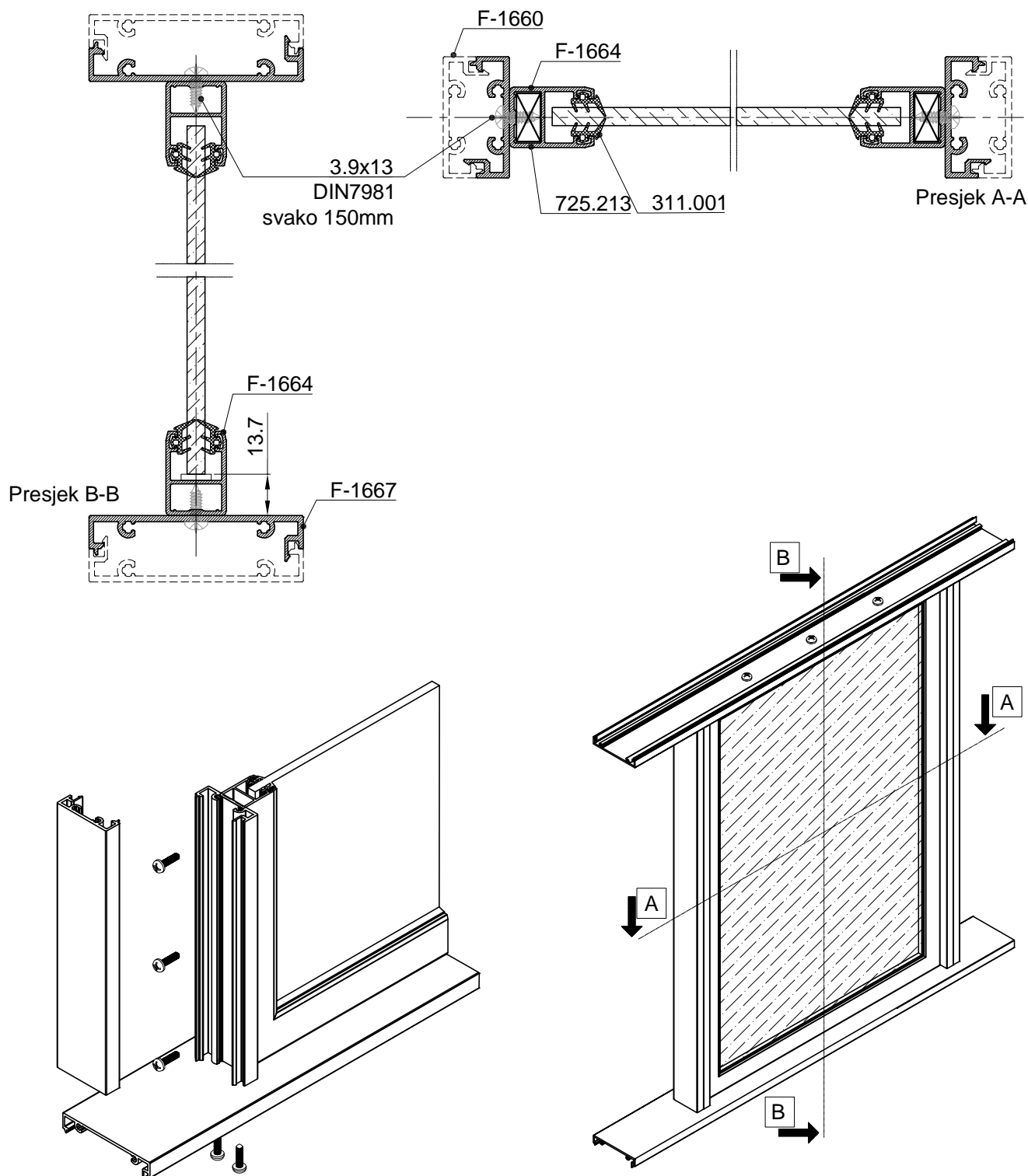

#### Prikaz montaže sa staklenom ispunom

1. Sklopiti ram F-1664 za koji su vezani profili F-1541
2. Umetnuti ispunu (staklo d=6mm) unutar rama i montirati gorinji horizontalni pojas
3. Ram sa staklom montirati na segment ograde

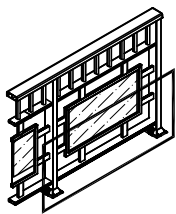

Tip: K

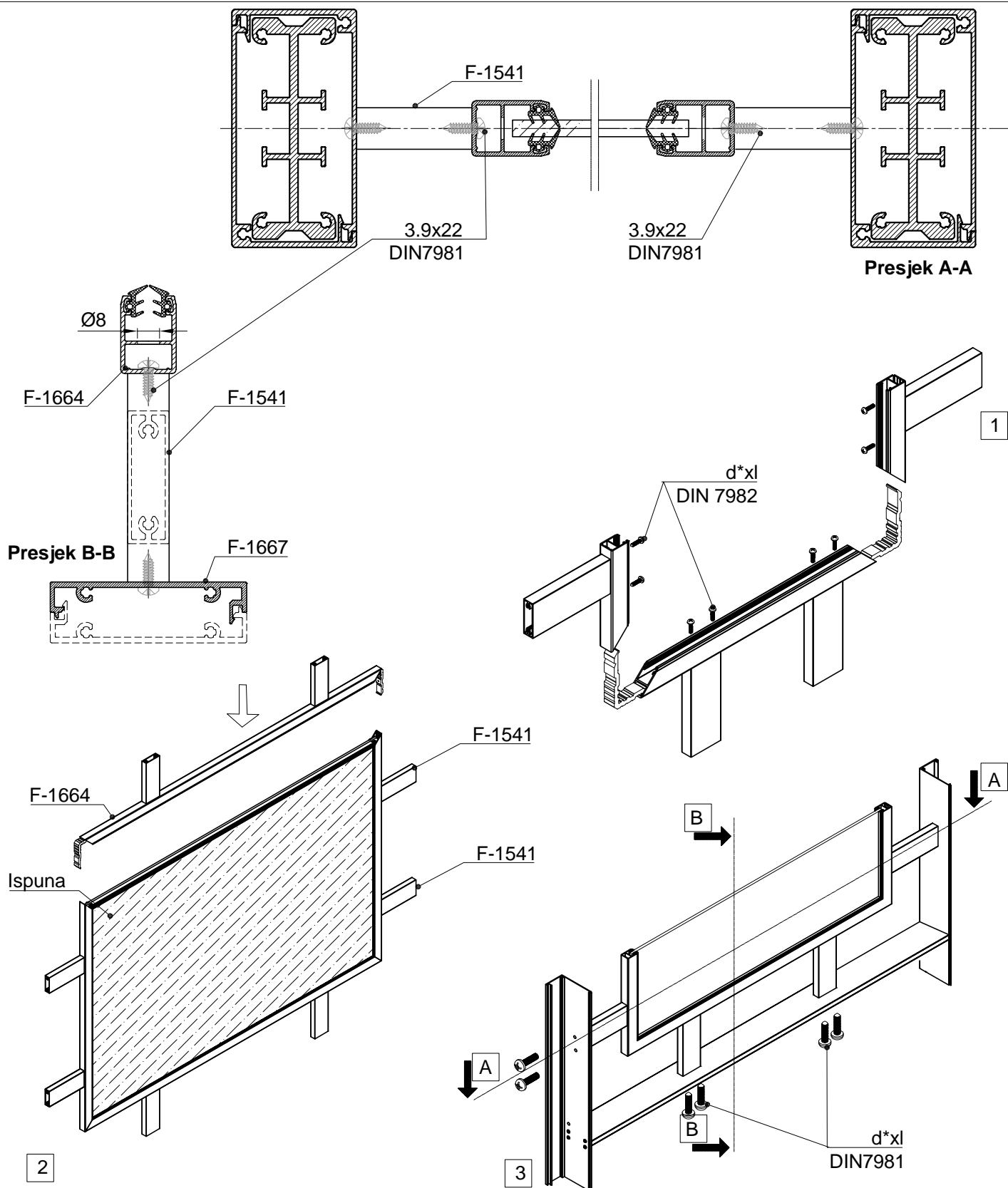

#### Prikaz montaže sa staklenom ispunom

1. Sklopiti ram F-1664 sa staklenom ispunom
2. Ram vezati s vertikalnim profilima stuba F-1666
3. Takav sklop kao segment montirati na stubove

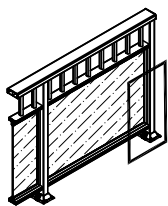

Tip: L

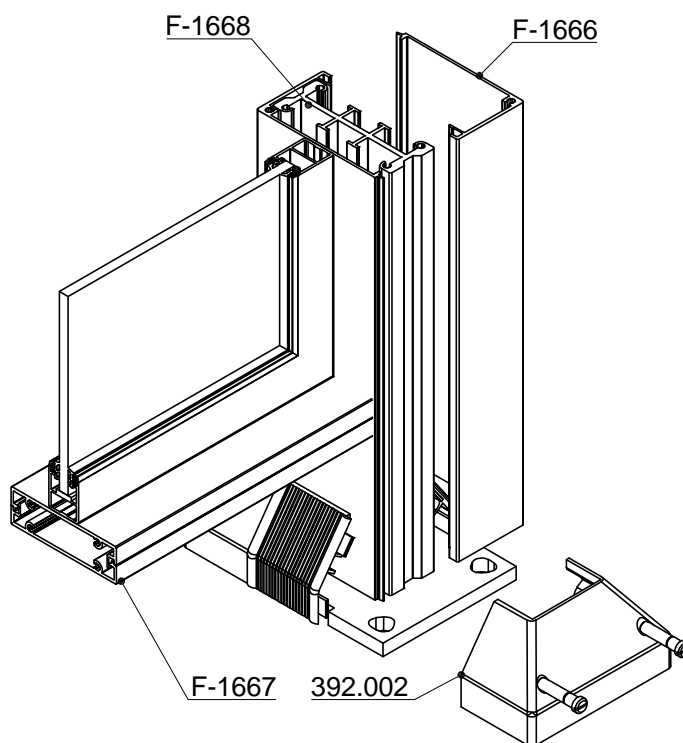
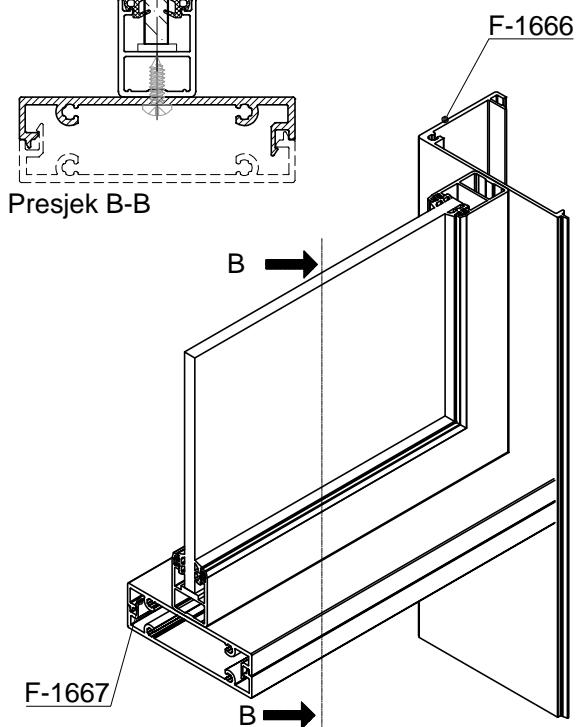
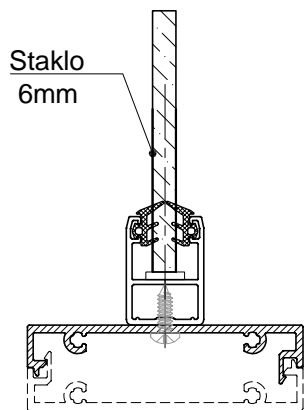
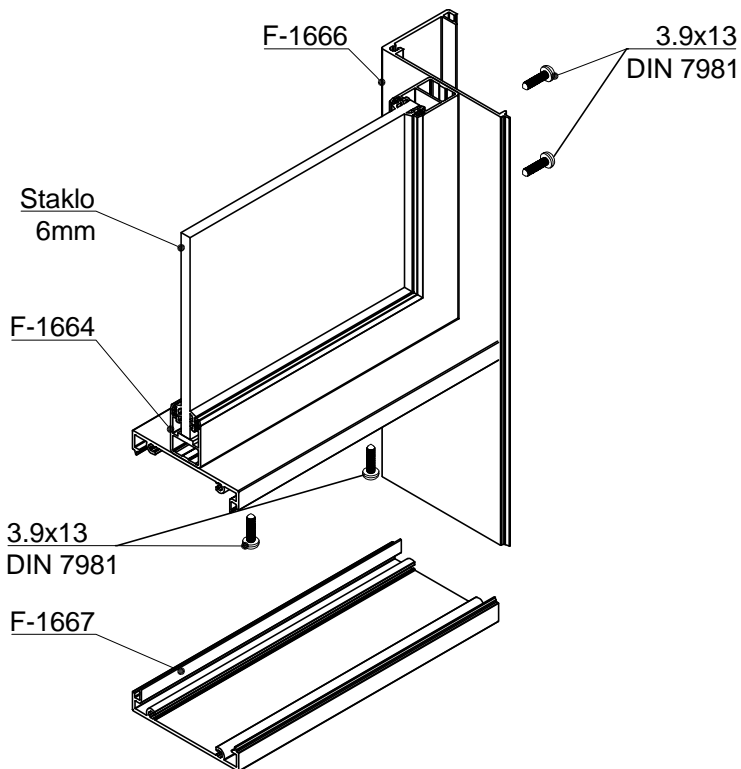
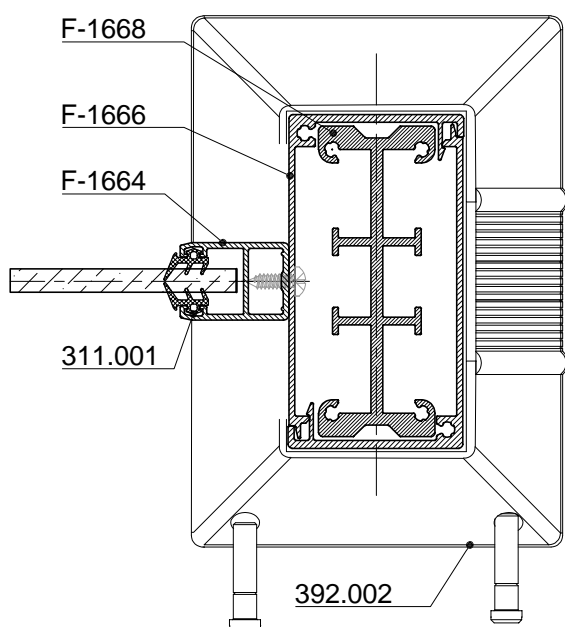

d\*x l DIN 7981 prečnik vijka prema tabeli 1

#### Prikaz montaže gornje prečke

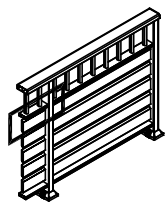

Tip: A

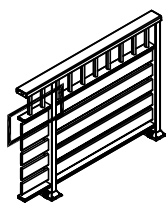

Tip: B

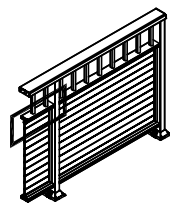

Tip: C

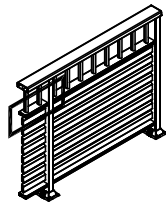

Tip: D

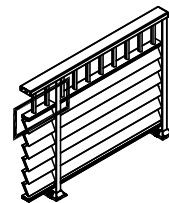

Tip: E

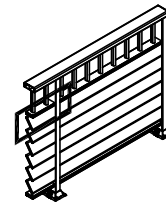

Tip: F

M 1:2

Mogući izbor profila	
F-1660	
F-1667	

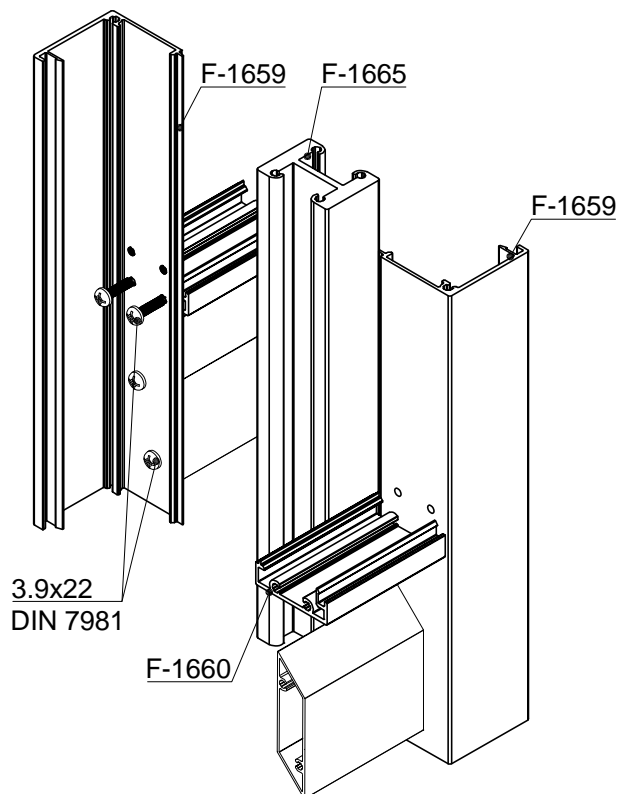

Stub 45x45

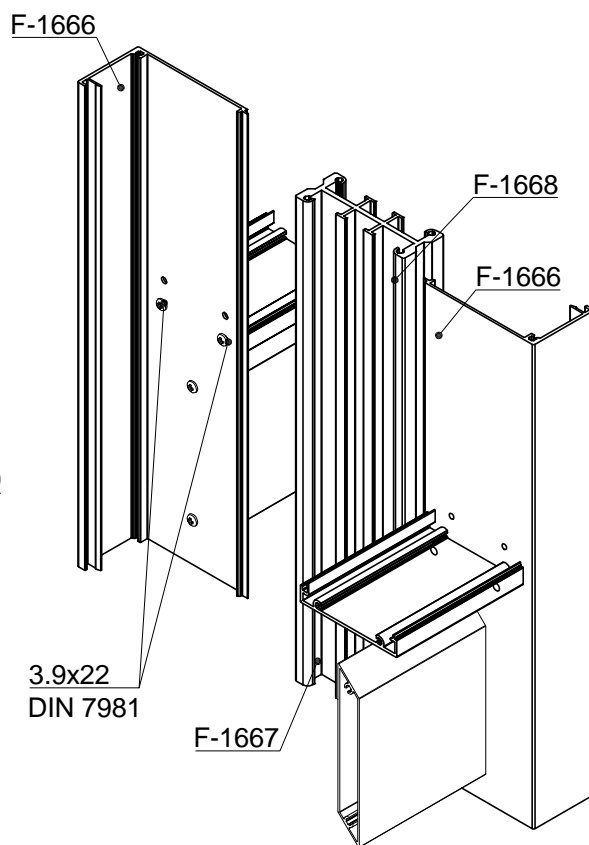

Stub 45x86

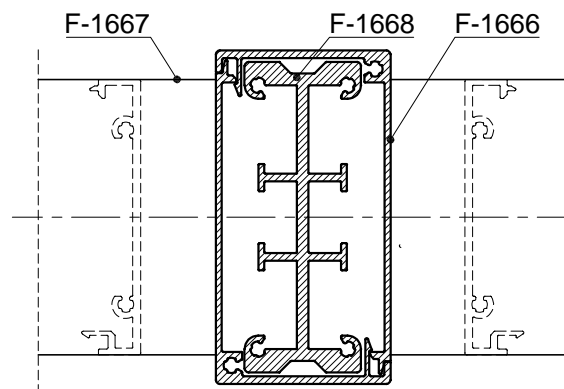
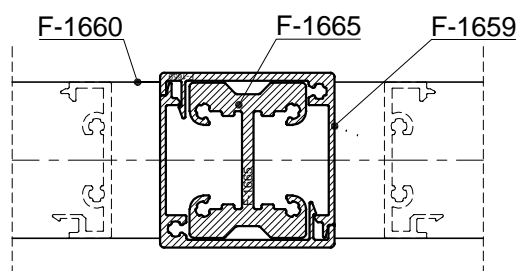

#### Prikaz montaže gornjeg dijela segmenta

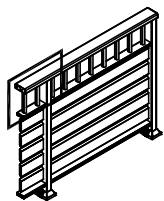

Tip: A

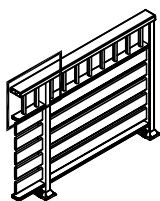

Tip: B

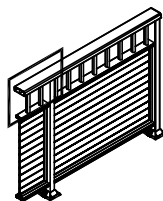

Tip: C

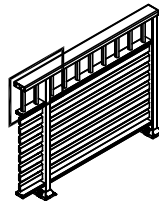

Tip: D

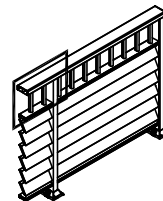

Tip: E

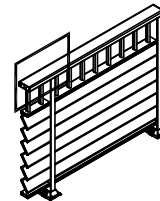

Tip: F

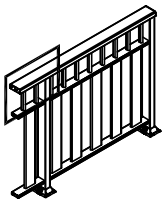

Tip: I

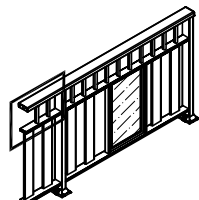

Tip: J

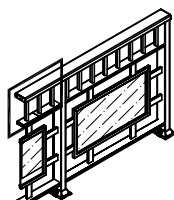

Tip: K

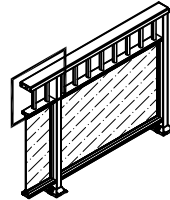

Tip: L

M 1:2

\*-Mogući izbor profila

OG-111	
F-0829	
F-1541	
F-1139	
F-1662	

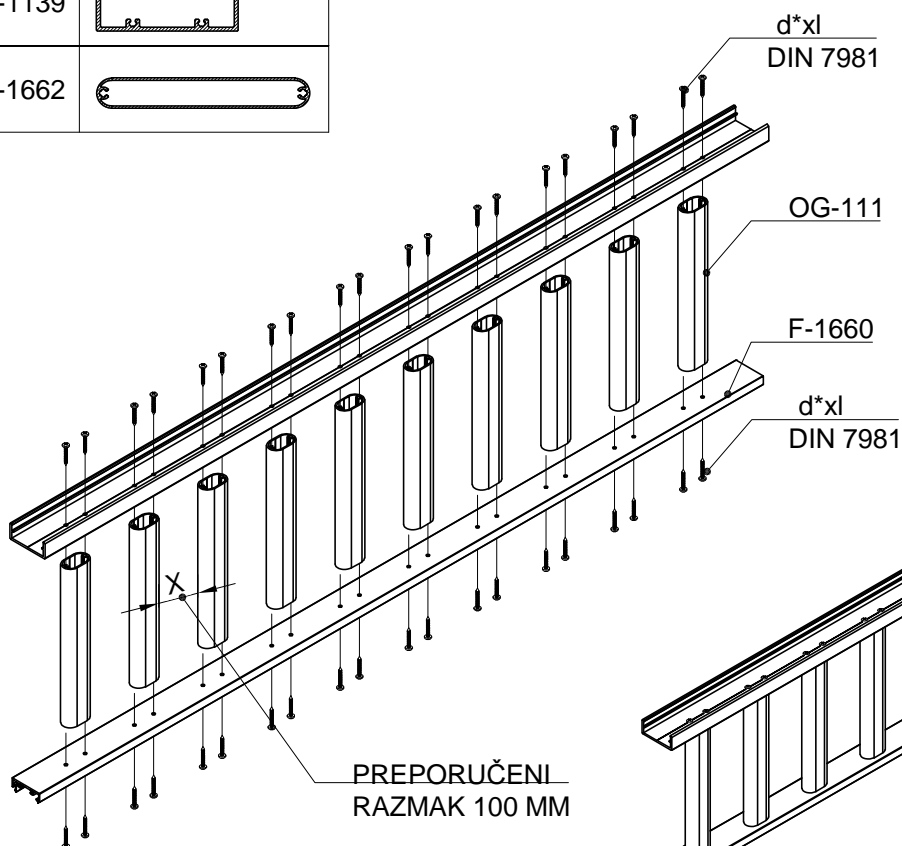
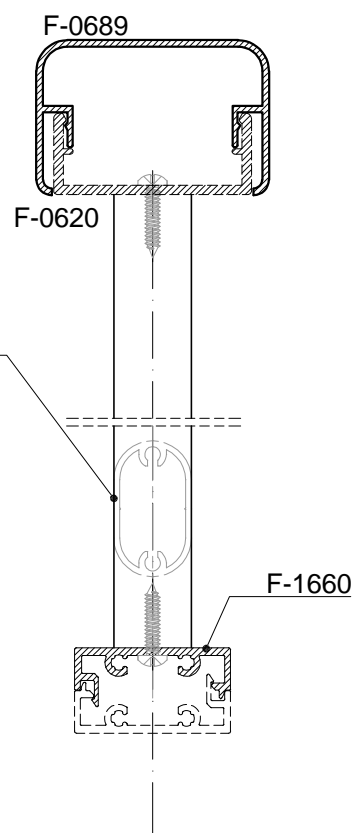

#### Prikaz montaže gornjeg dijela segmenta

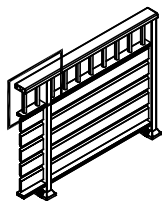

Tip: A

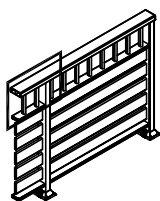

Tip: B

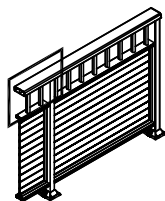

Tip: C

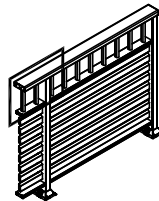

Tip: D

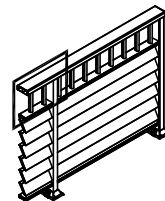

Tip: E

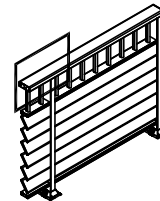

Tip: F

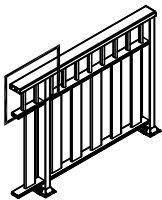

Tip: I

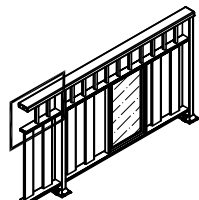

Tip: J

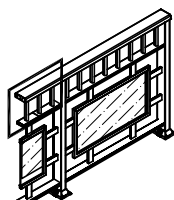

Tip: K

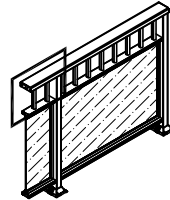

Tip: L

M 1:2

\*-Mogući izbor profila

OG-111	
F-0829	
F-1541	
F-1139	

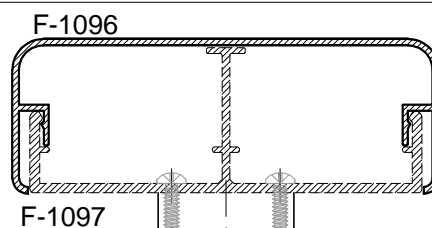

Moguće ugradnje različitih ispuna

F-1667

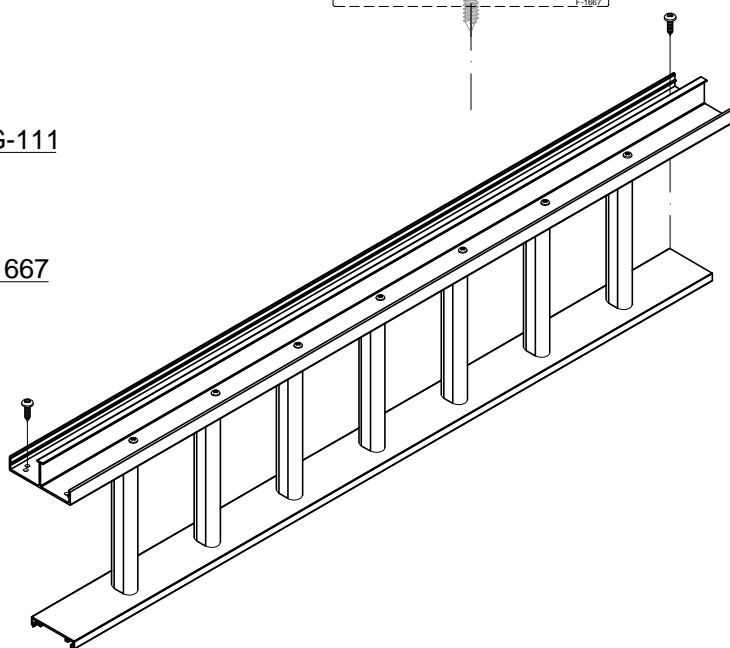
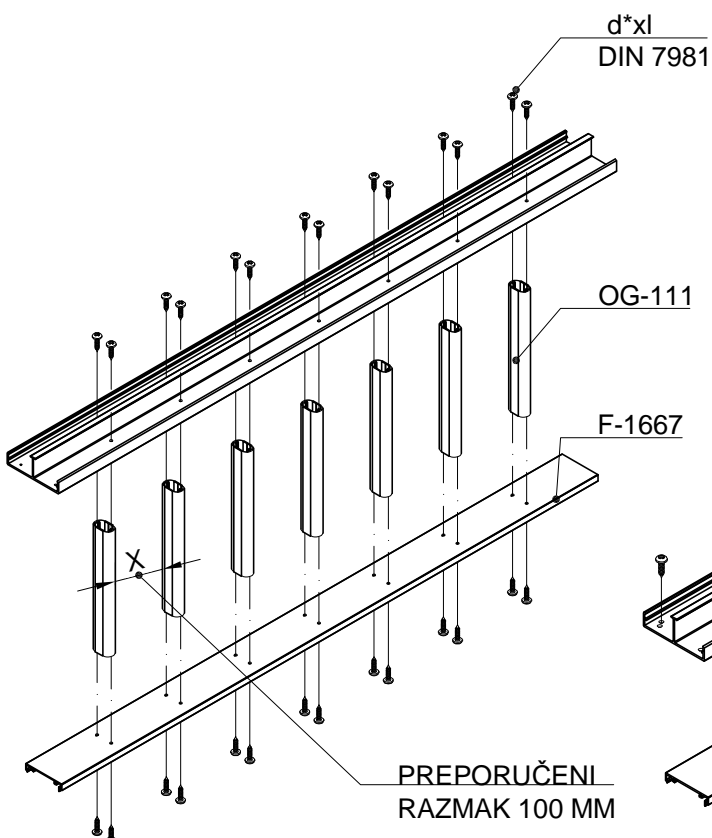

#### Prikaz montaže gornjeg dijela segmenta

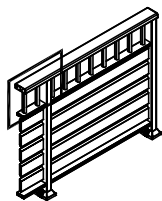

Tip: A

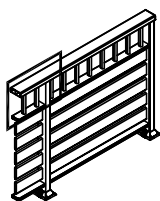

Tip: B

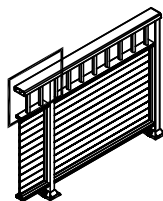

Tip: C

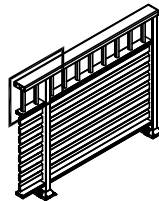

Tip: D

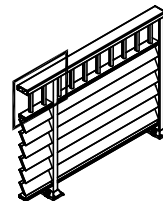

Tip: E

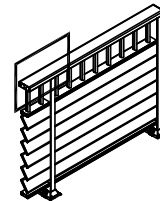

Tip: F

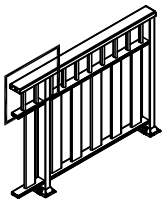

Tip: I

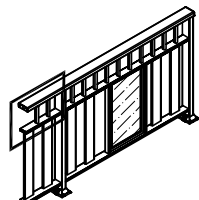

Tip: J

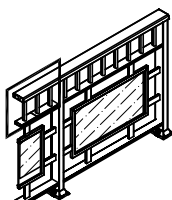

Tip: K

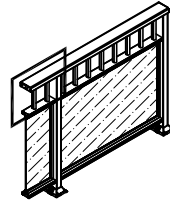

Tip: L

M 1:2

Mogući izbor profila

OG-111	
F-0829	
F-1541	
F-1139	

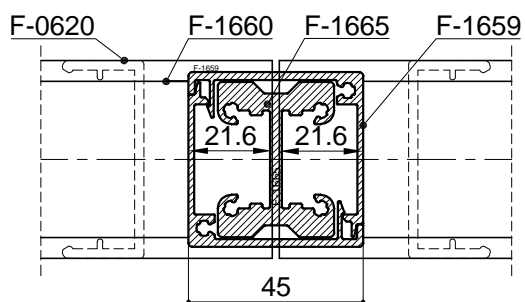
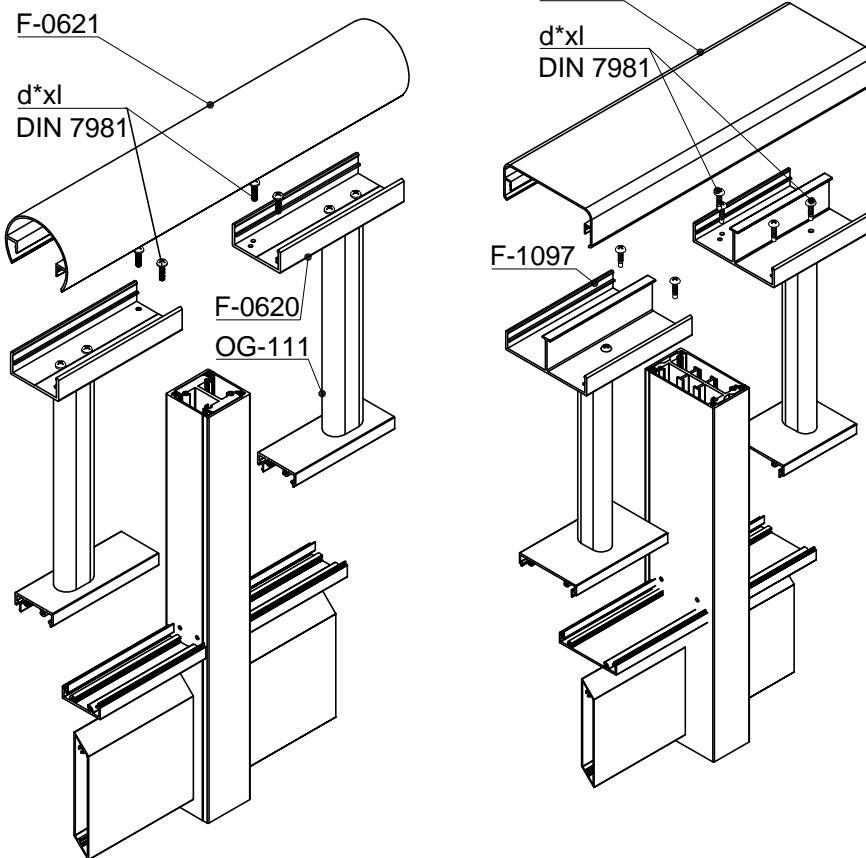

Stub 45x45

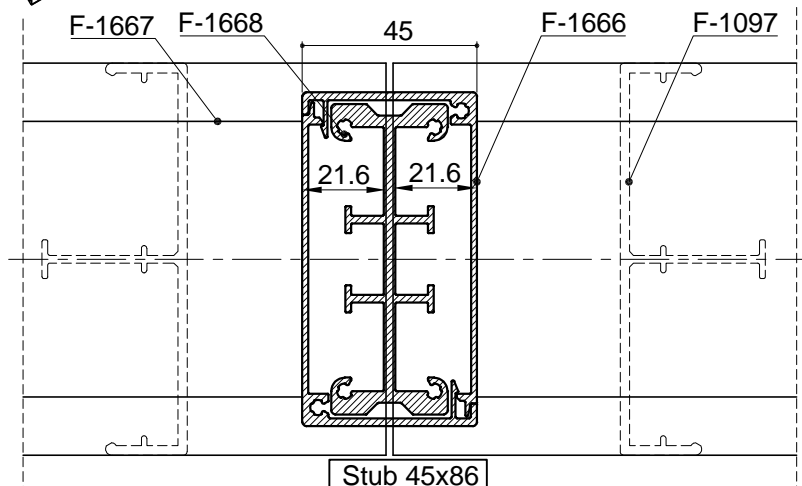

Stub 45x86

d\*x l DIN 7981 prečnik vijka prema tabeli 1

#### Prikaz montaže podrukhvata s rukohvatom

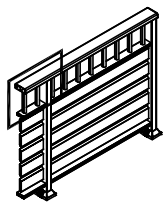

Tip: A

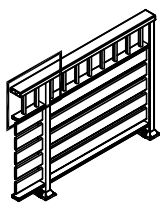

Tip: B

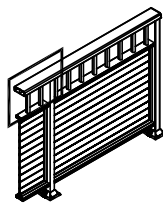

Tip: C

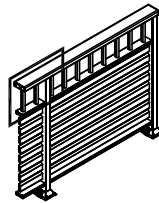

Tip: D

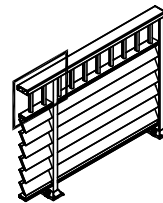

Tip: E

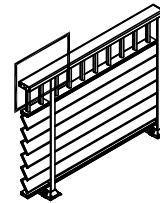

Tip: F

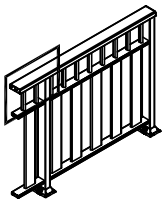

Tip: I

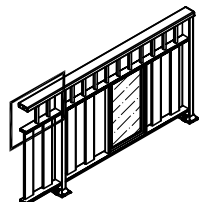

Tip: J

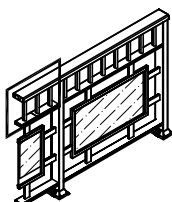

Tip: K

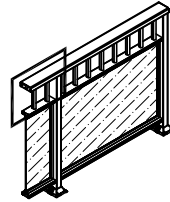

Tip: L

M 1:4

Mogući izbor profila

F-0620	
F-0673	
F-0673/A	
F-1334	
F-0621	
F-0689	
F-1097	
F-1096	

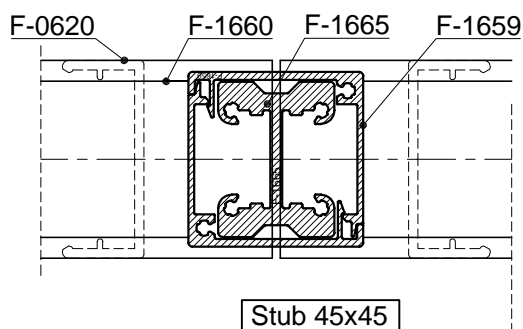
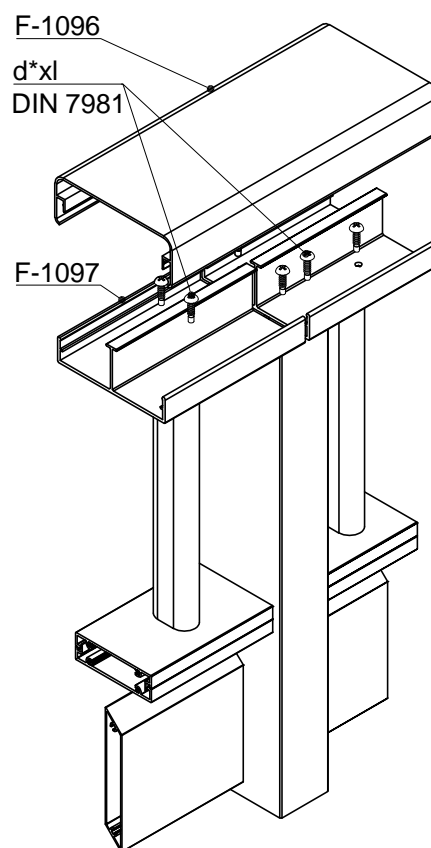
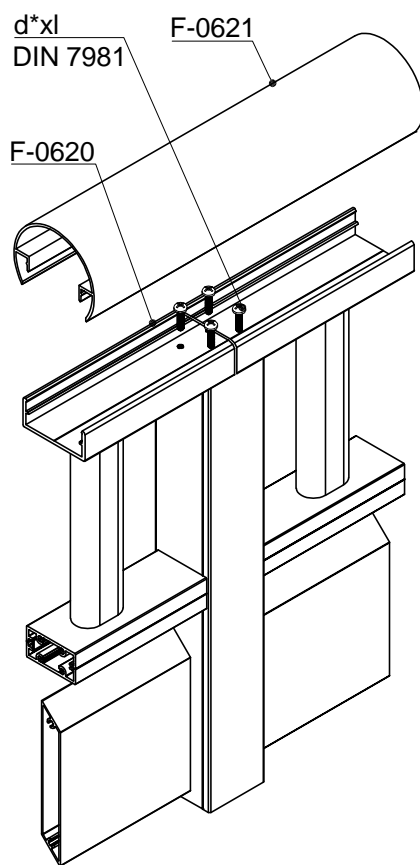

Stub 45x45

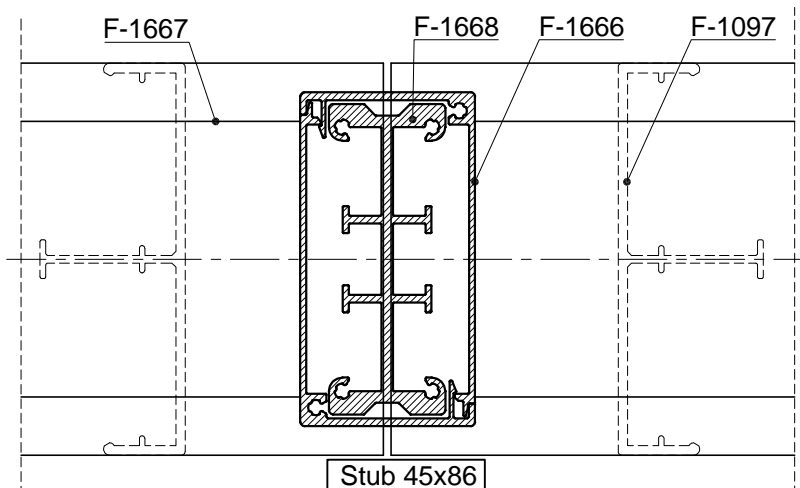

Stub 45x86

d\*x l DIN 7981 prečnik vijka prema tabeli 1

#### Prikaz montaže završetka segmenta

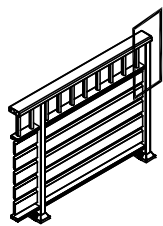

Tip: A

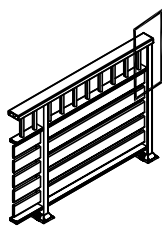

Tip: B

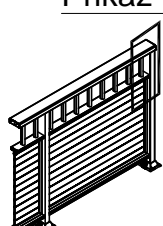

Tip: C

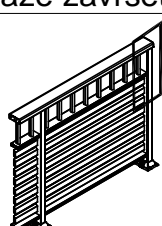

Tip: D

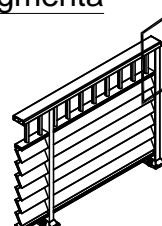

Tip: E

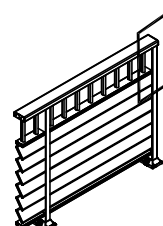

Tip: F

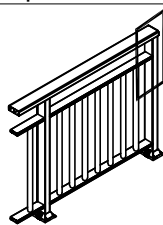

Tip: G

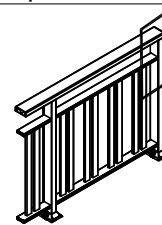

Tip: H

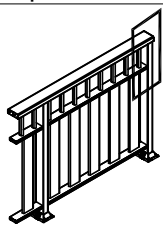

Tip: I

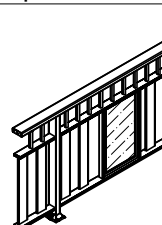

Tip: J

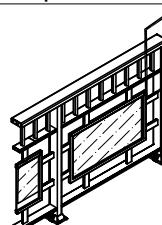

Tip: K

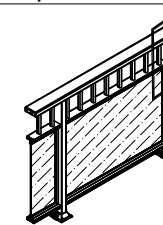

Tip: L

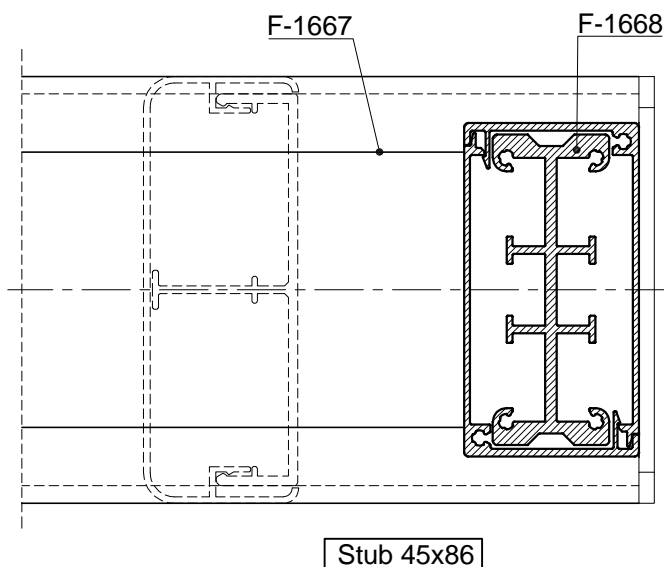
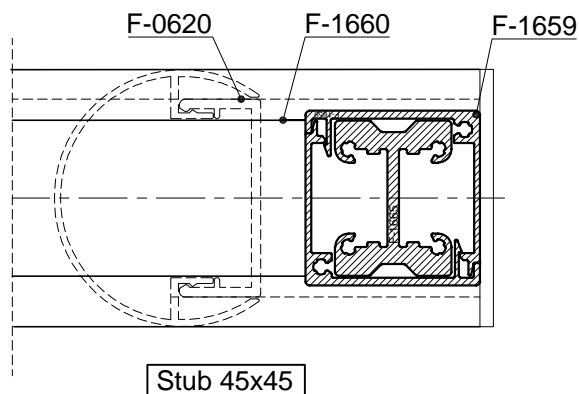
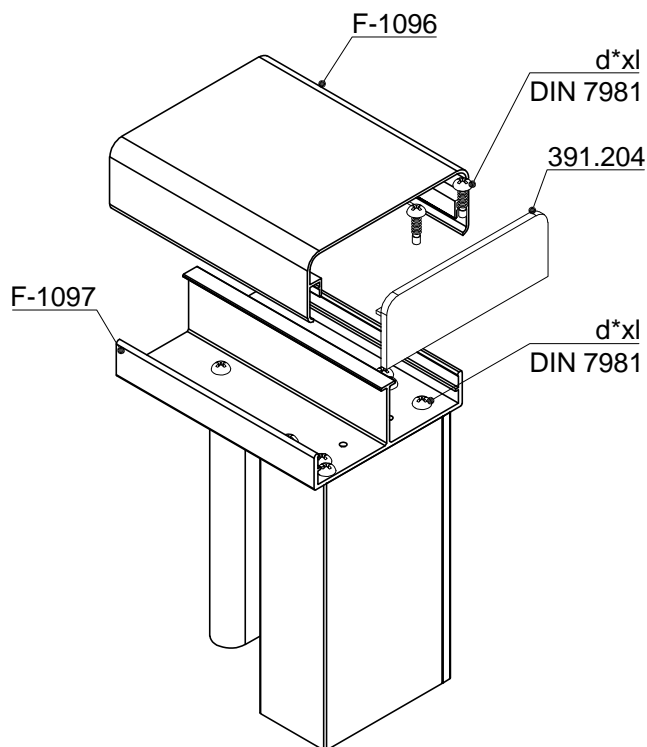
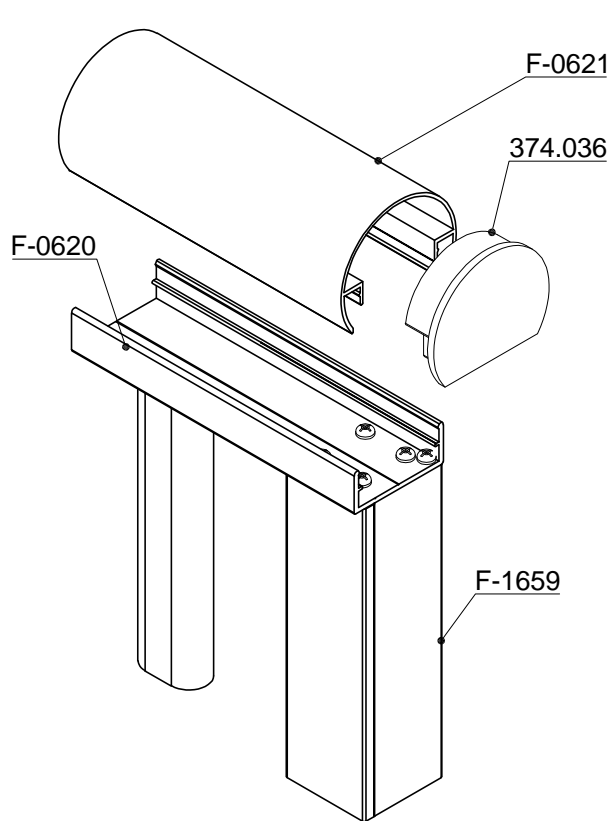

d\*x l DIN 7981 prečnik vijka prema tabeli 1

Prikaz montaže ograde 90°

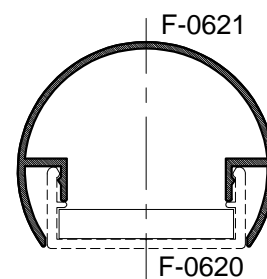
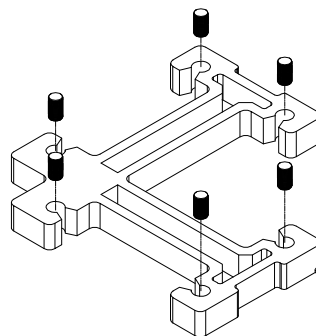
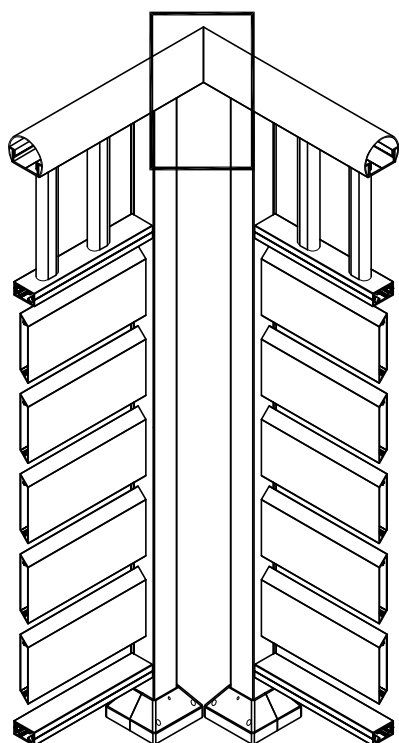

521.049  
Veznik pod kutem  
Vijak M6x8 DIN 913

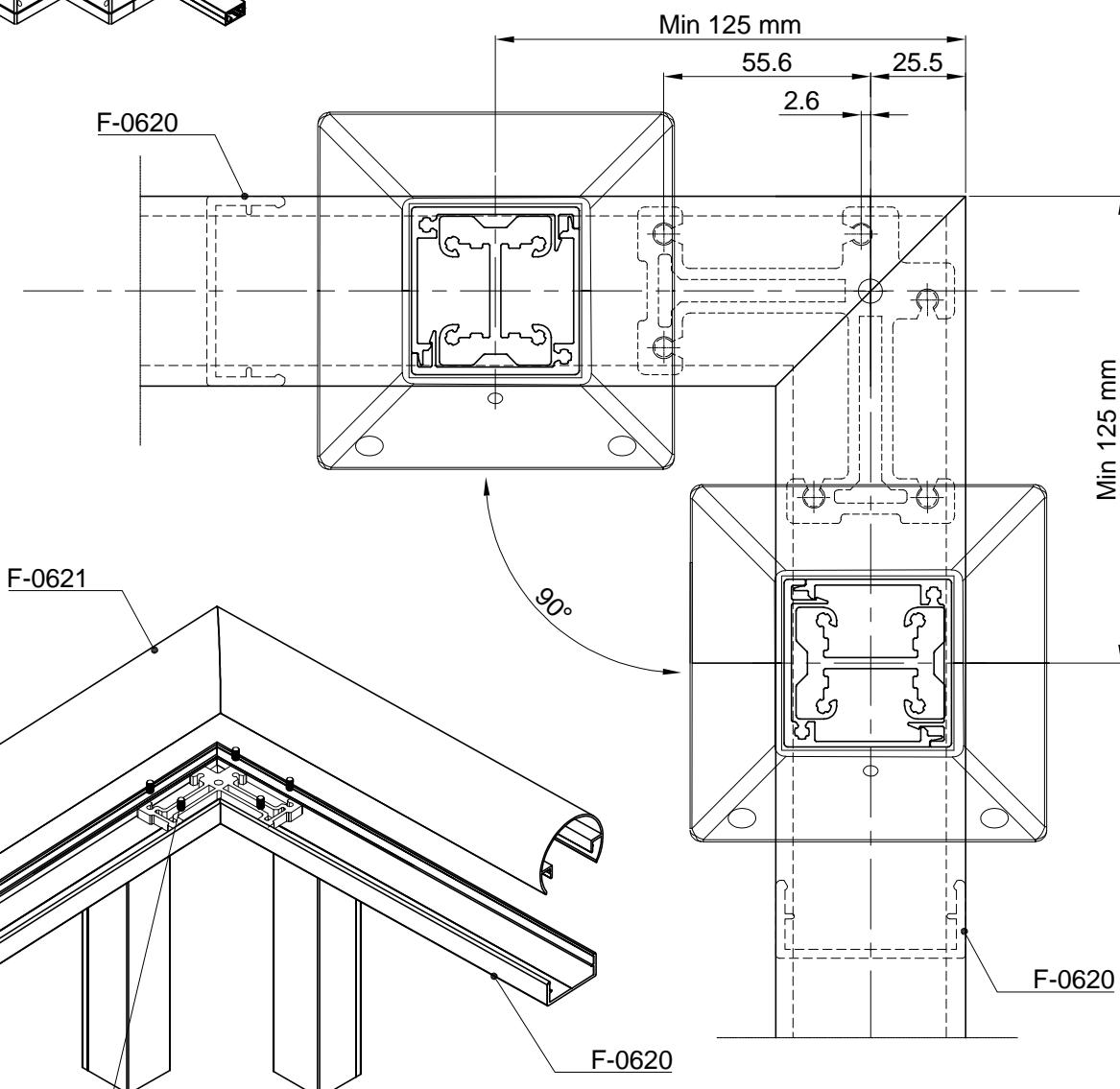

521.049  
Veznik pod kutem  
Vijak M6x8 DIN 913

Prikaz montaže ograde 90°

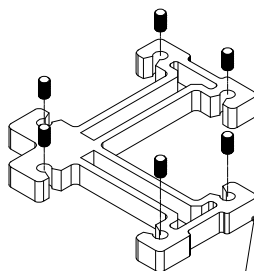
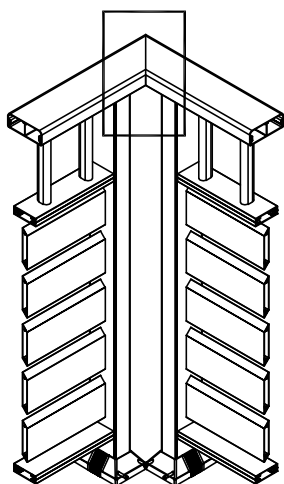

521.049  
Veznik pod kutem  
Vijak M6x8 DIN 913

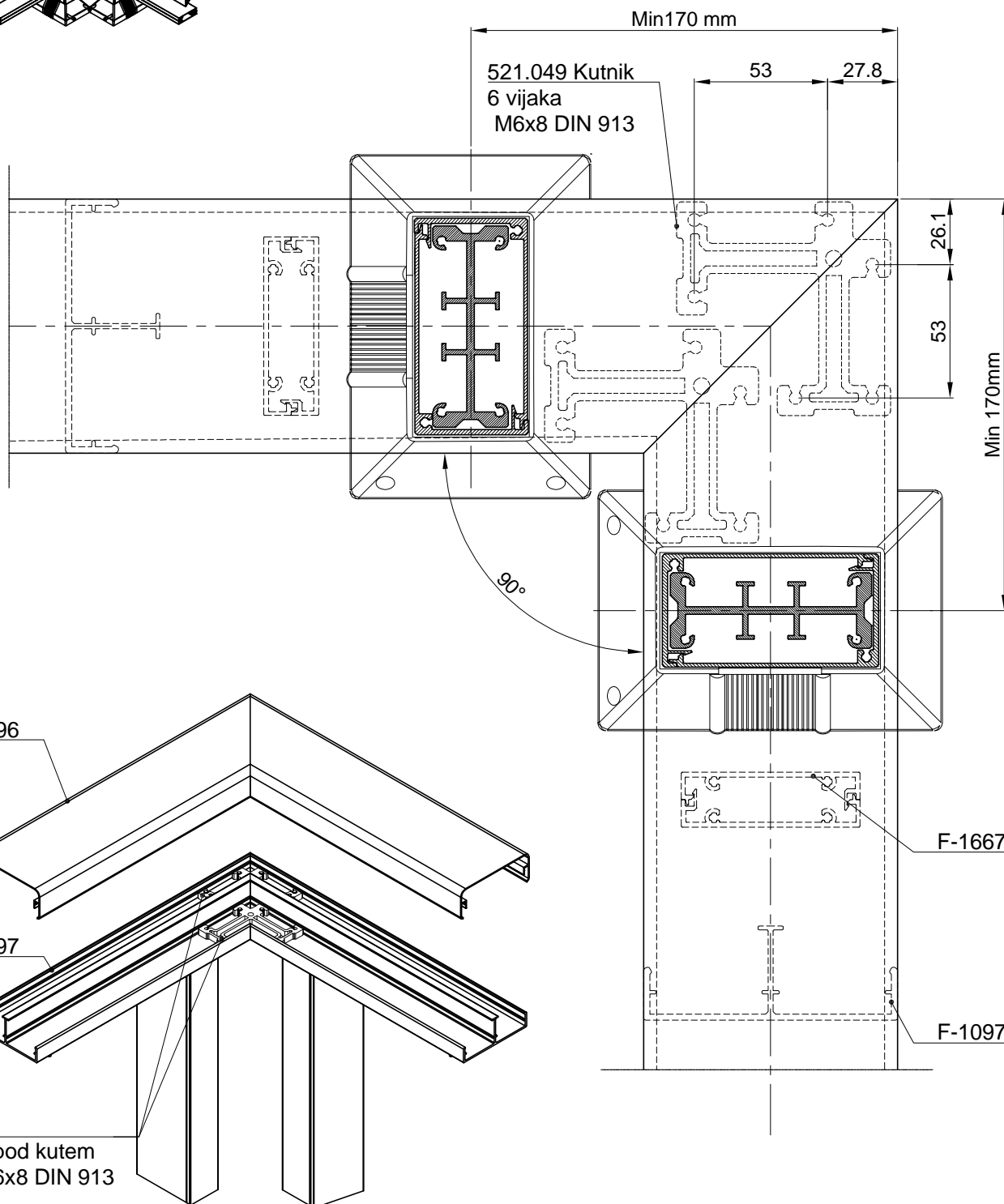
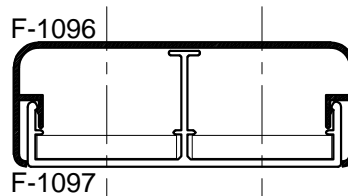

#### Prikaz montaže ograde pod promjenljivim kutom

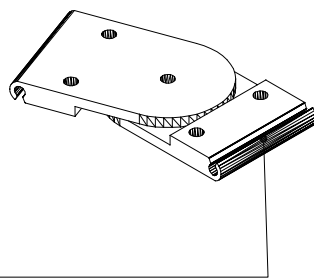
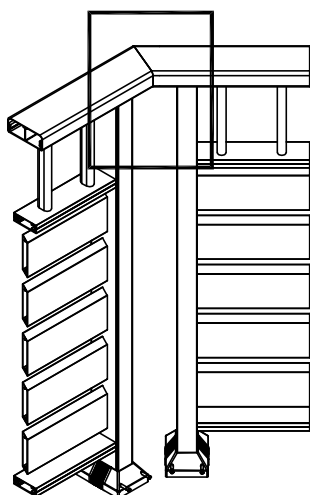

521.051  
Veznik sa promjenljivim kutom  
Vijak M6x8 DIN 913

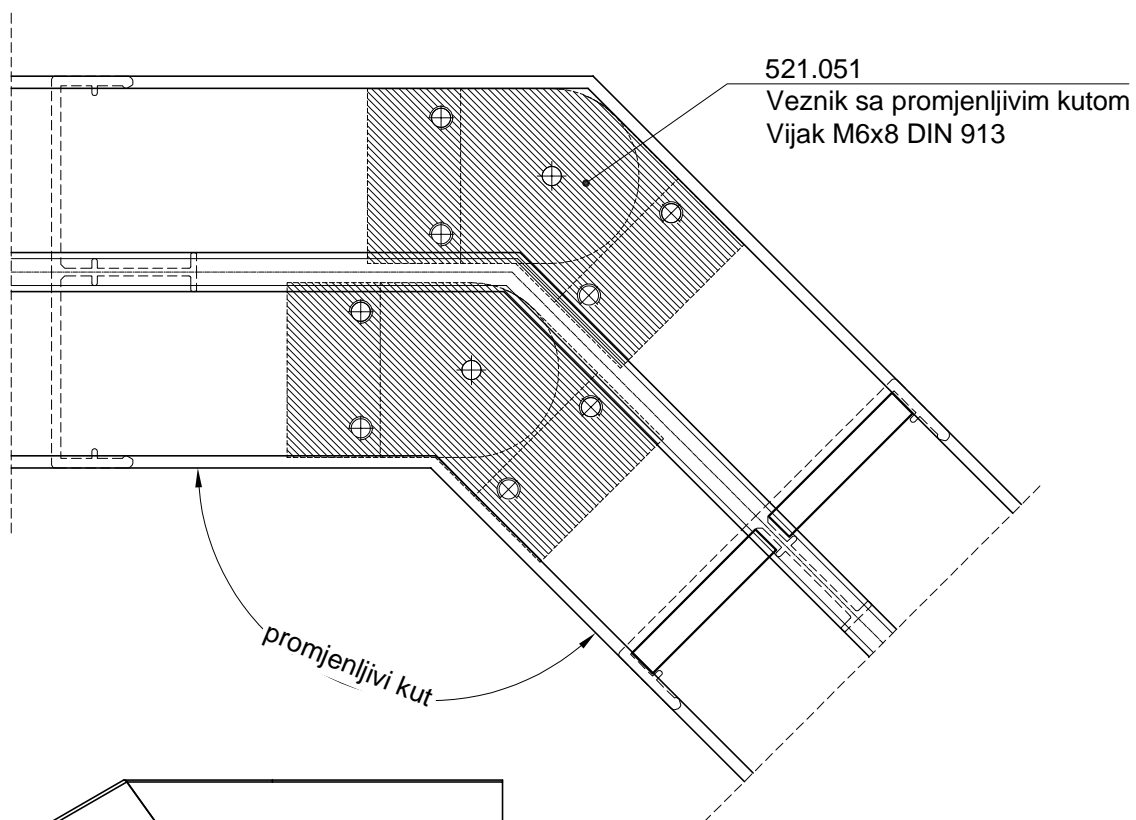
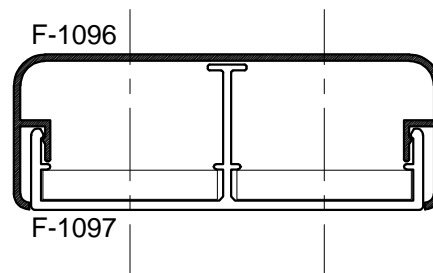

521.051  
Veznik sa promjenljivim kutom  
Vijak M6x8 DIN 913

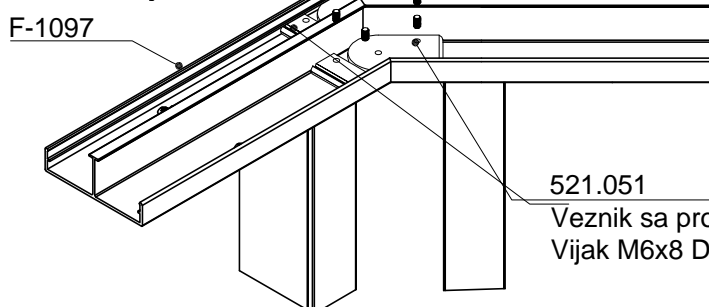
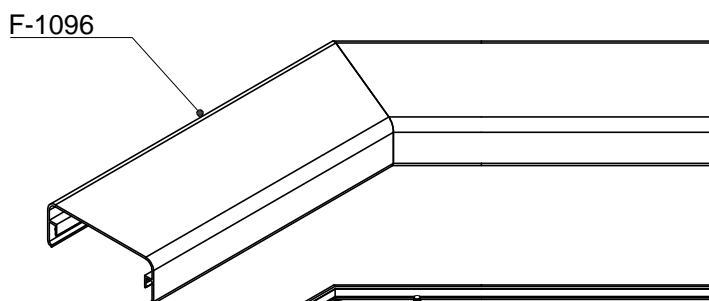

521.051  
Veznik sa promjenljivim kutom  
Vijak M6x8 DIN 913

#### Prikaz montaže ograde pod promjenljivim kutom

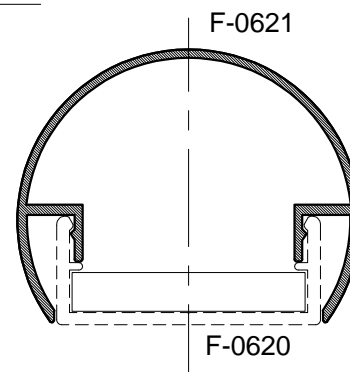
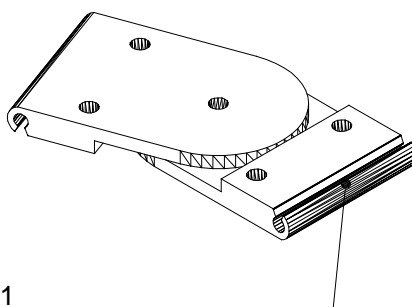
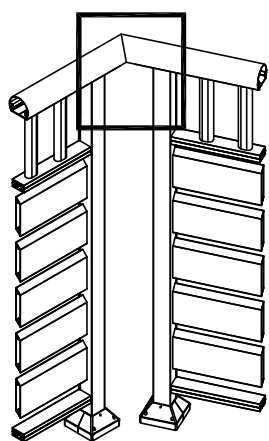

521.051  
Veznik sa promjenljivim kutom  
Vijak M6x8 DIN 913

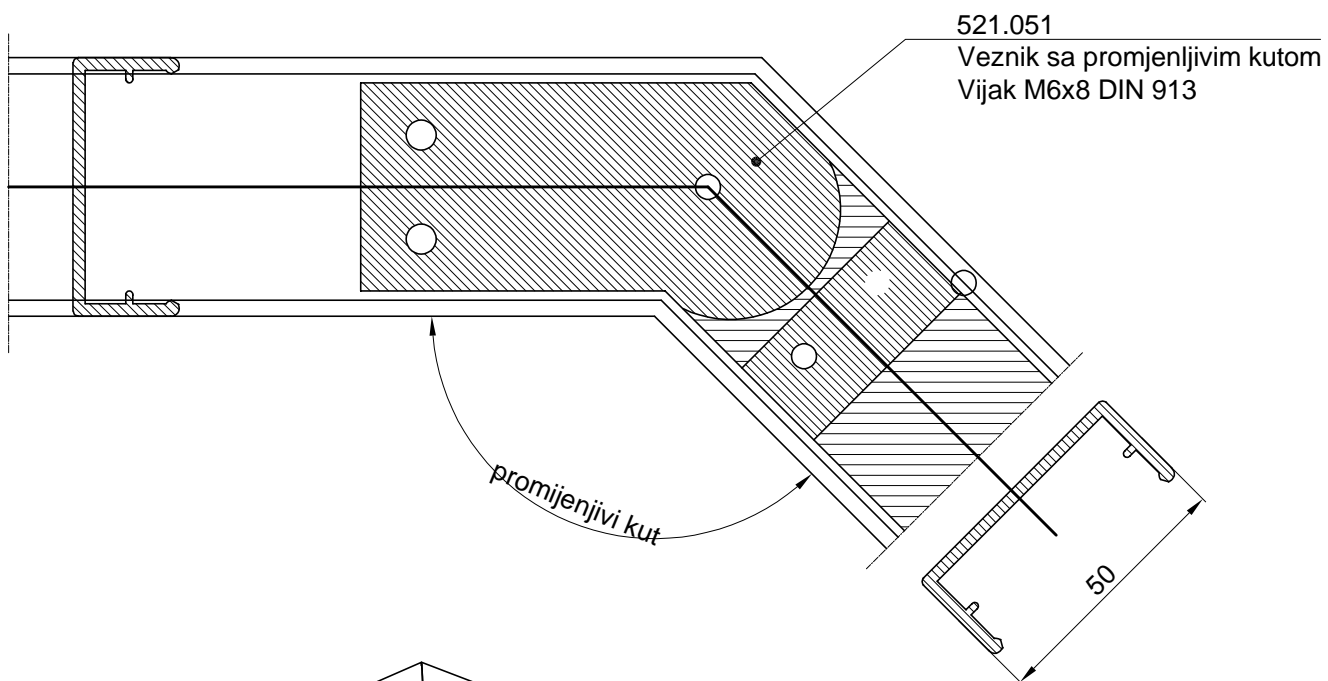

521.051  
Veznik sa promjenljivim kutom  
Vijak M6x8 DIN 913

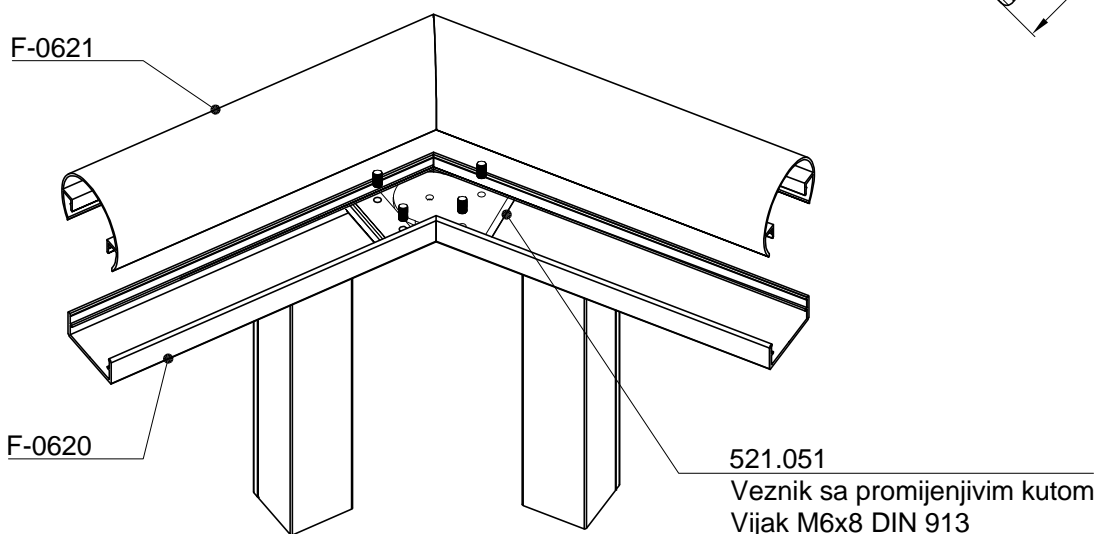

521.051  
Veznik sa promijenjivim kutom  
Vijak M6x8 DIN 913

#### Prikaz montaže ograde pod promjenljivim kutom

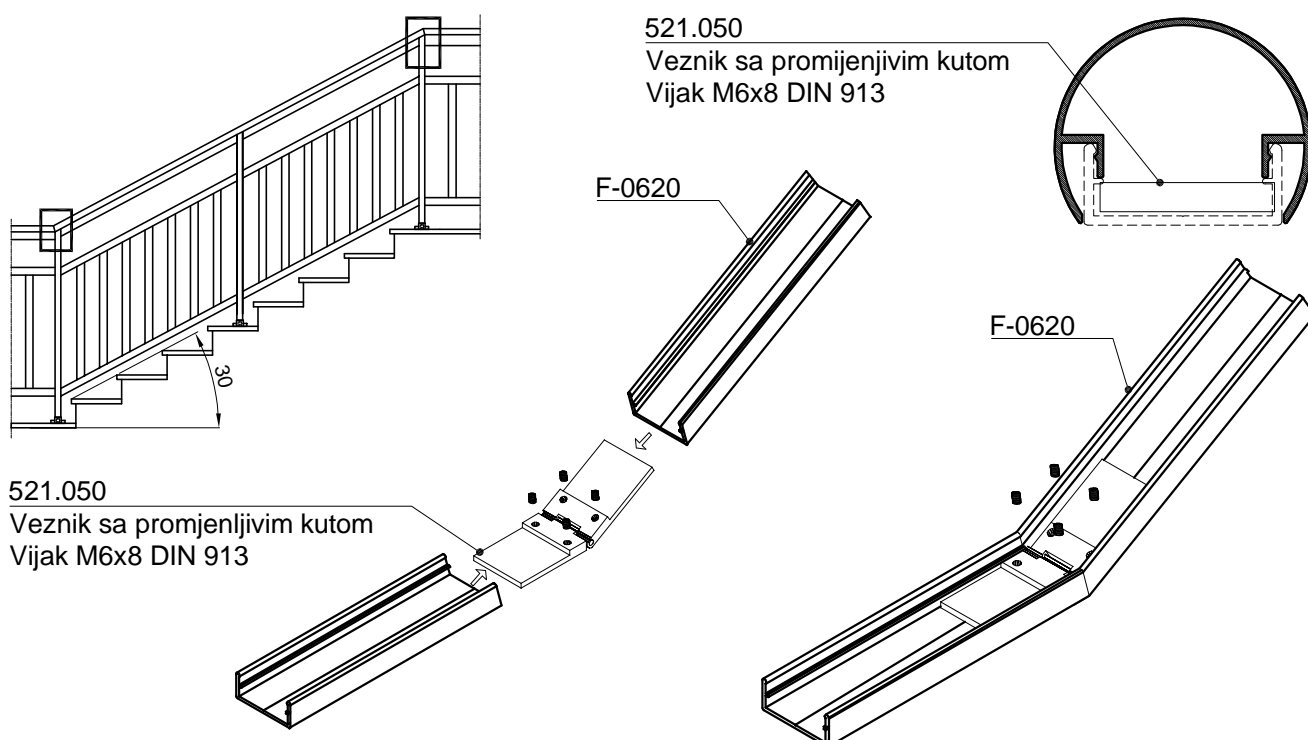
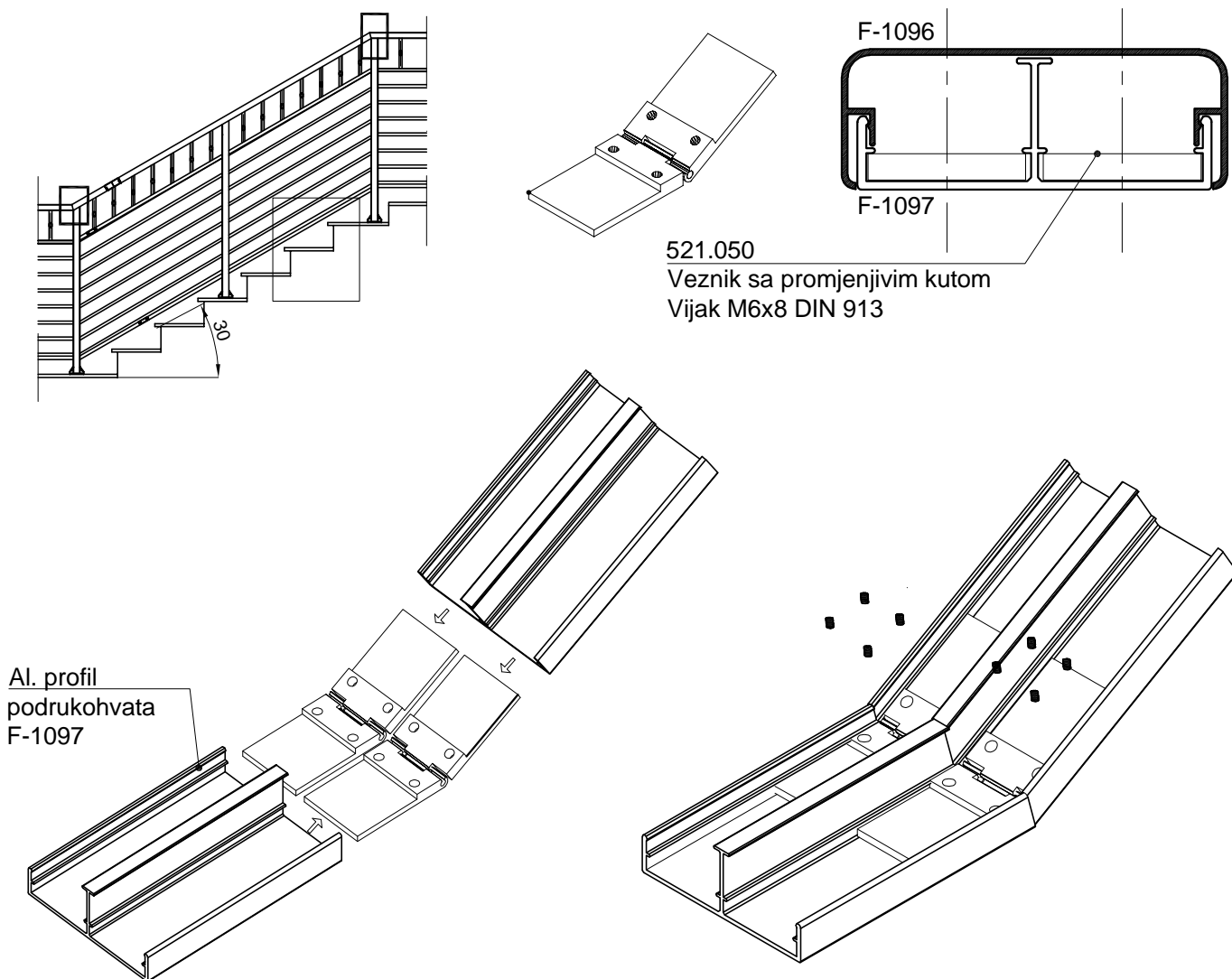

#### Prikaz montaže rozete

#### Montaža rozete 391.001 na stub 45x45

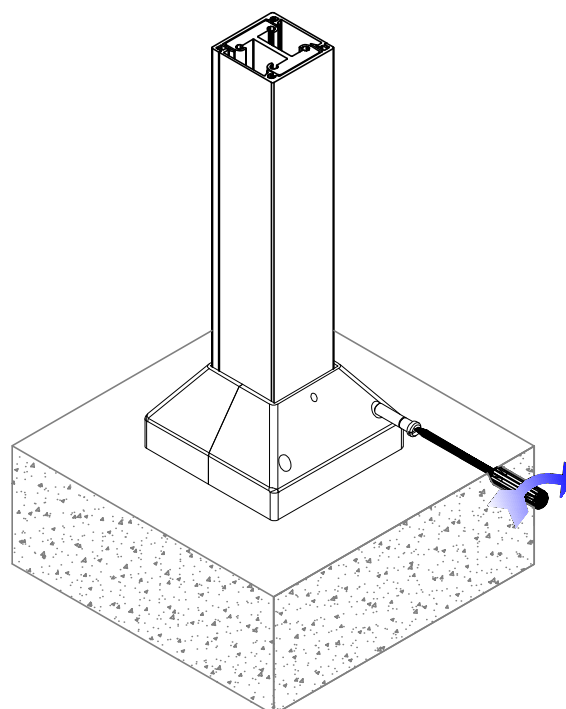
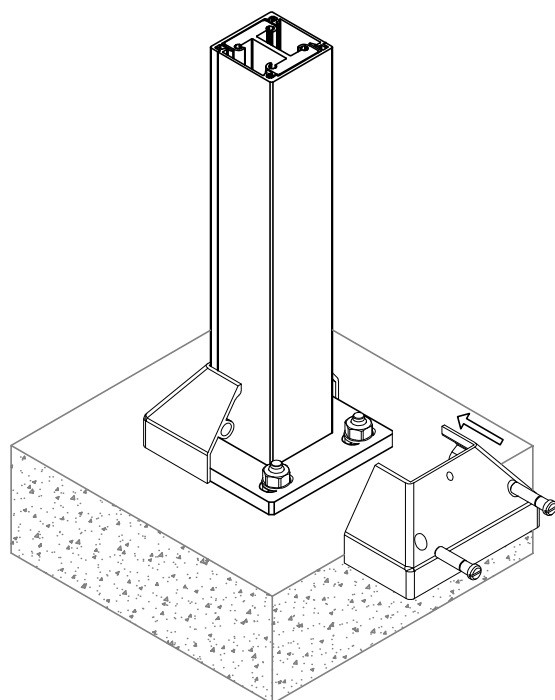
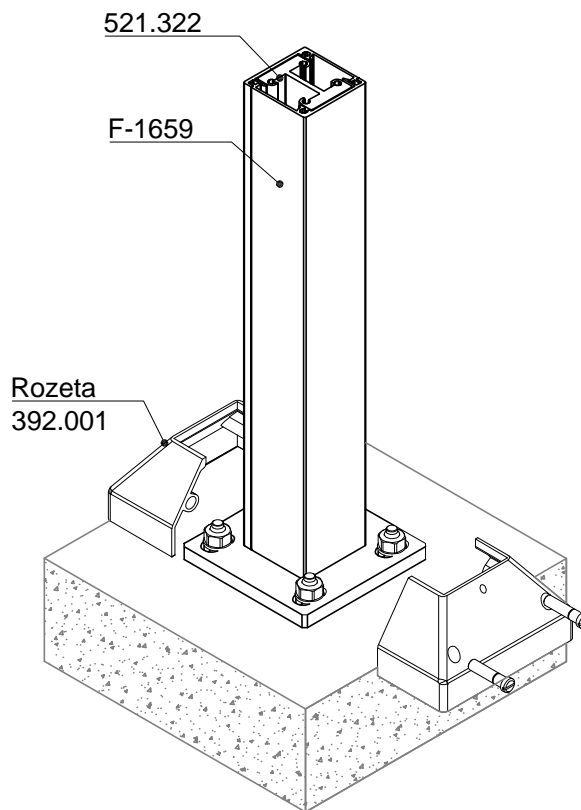
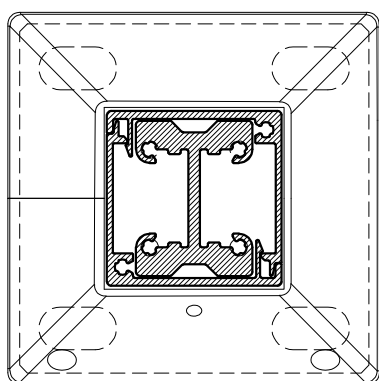
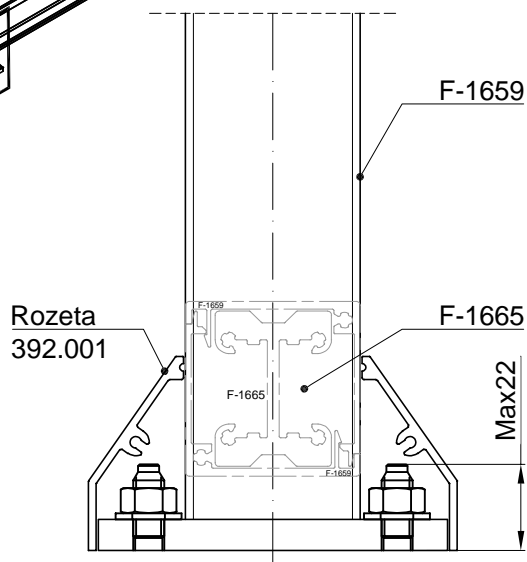
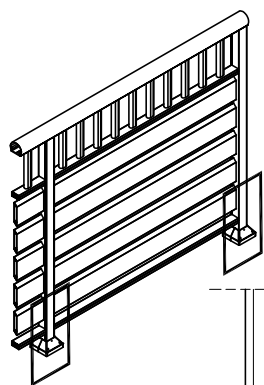

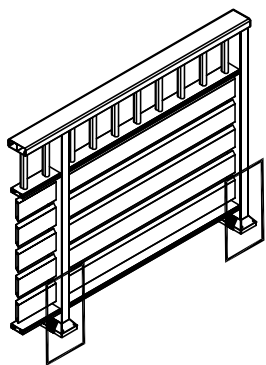

#### Prikaz montaže rozete

#### Montaža rozete 391.002 na stub 45x86

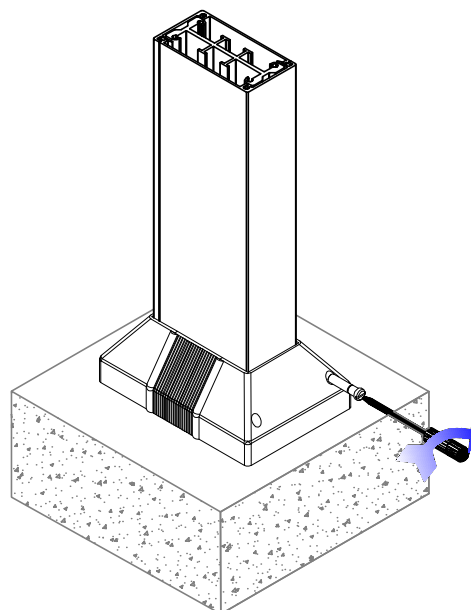
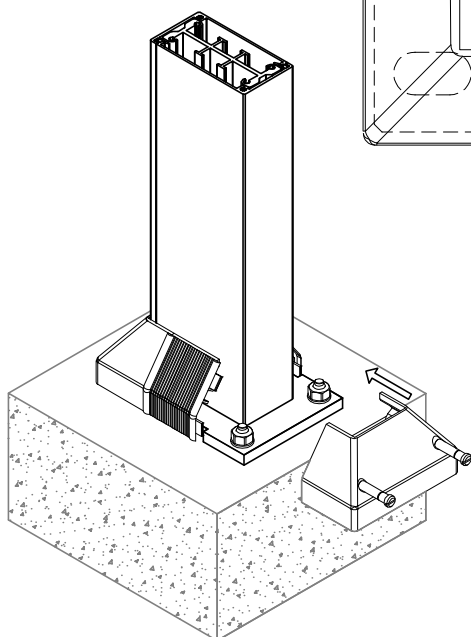
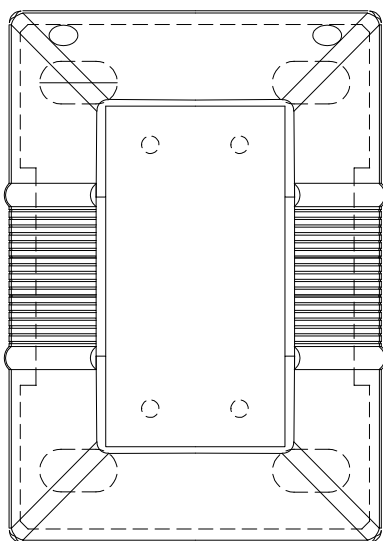
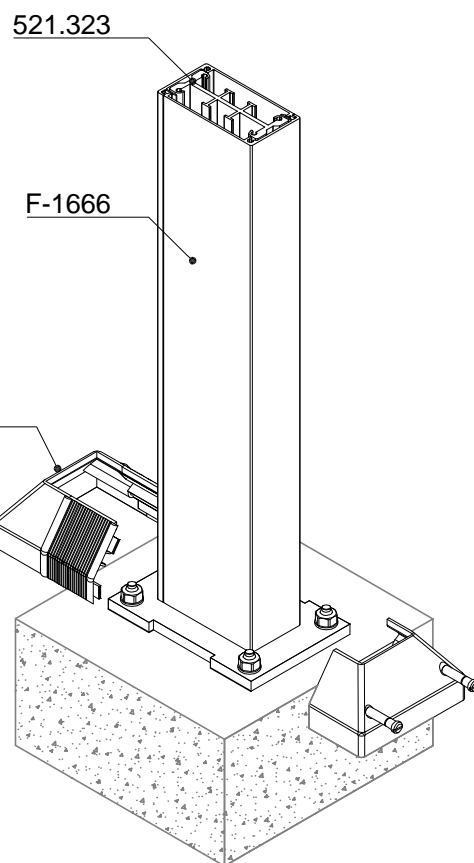
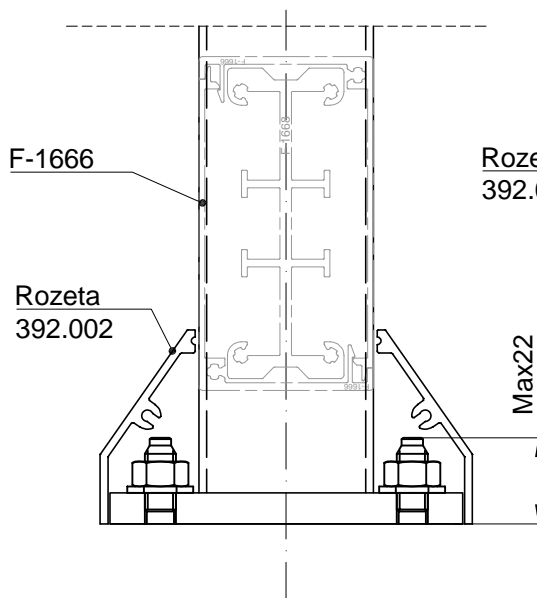

#### Prikaz montaže čepa dvorišne ograde

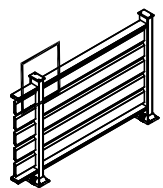

Tip: A1

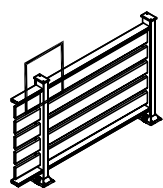

Tip: B1

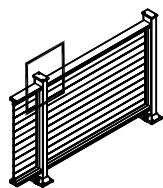

Tip: C1

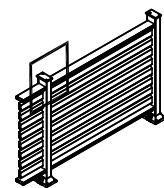

Tip: D1

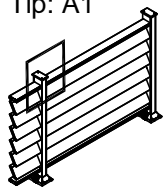

Tip: E1

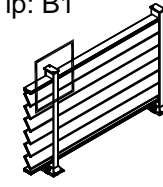

Tip: F1

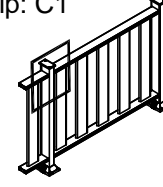

Tip: I1

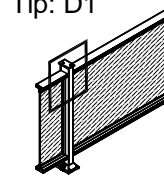

Tip: K1

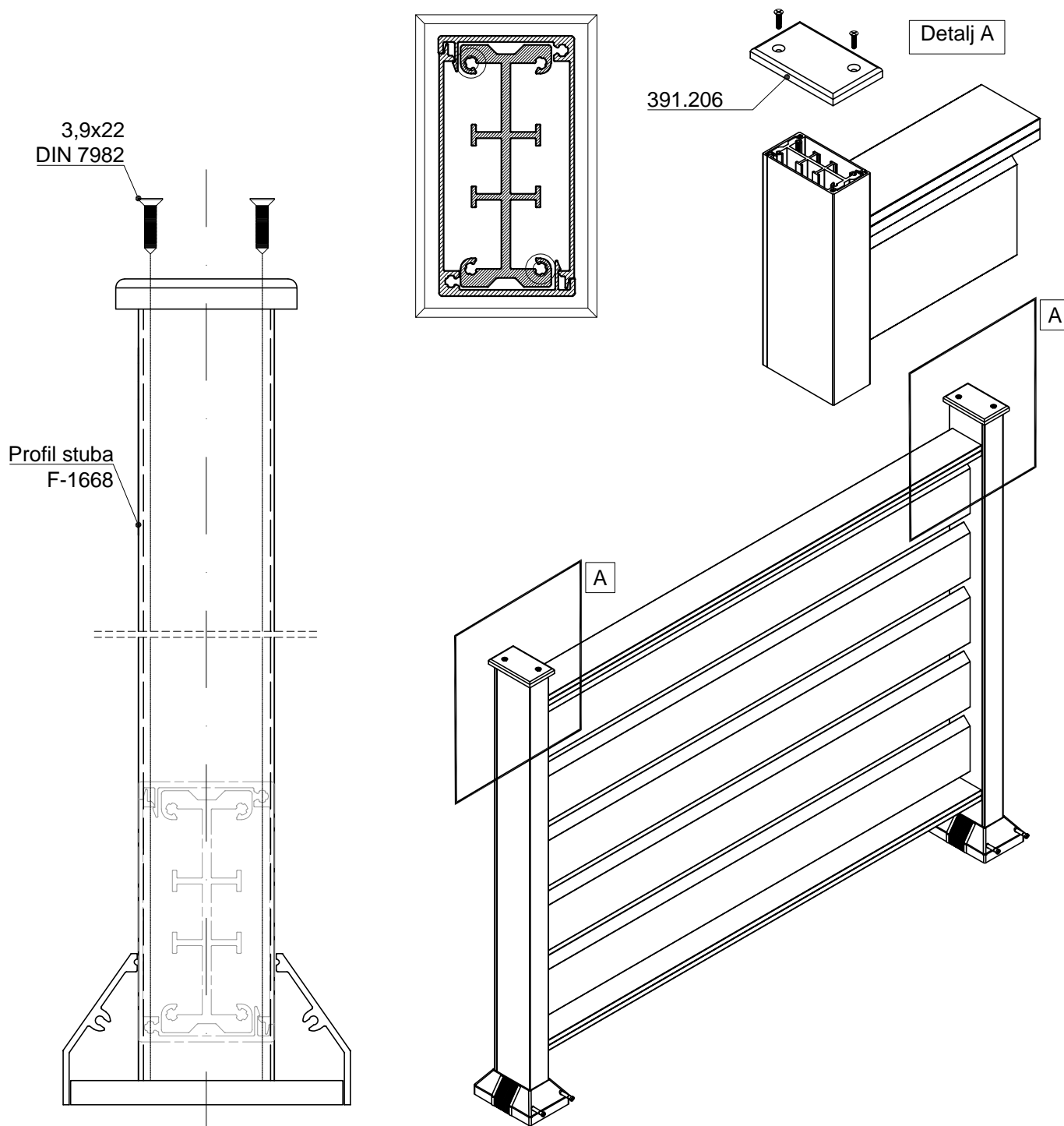

# Obrada i montaža



#### OF-80 Tip A-86

#### 1. Profili koji se koriste u segmentu:

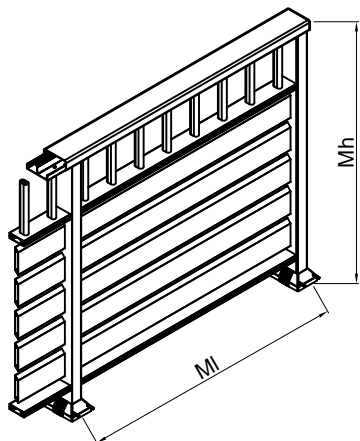

M 1:4

Profil segmenta	
F-1666 T=0.68kg/m	
F-1668 T=1.71kg/m	
F-1667 T=0.60kg/m	
F-1663 T=0.83kg/m	
F-1096 T=0.97kg/m	
F-1097 T=1.14kg/m	
OG-111 T=0.44kg/m	

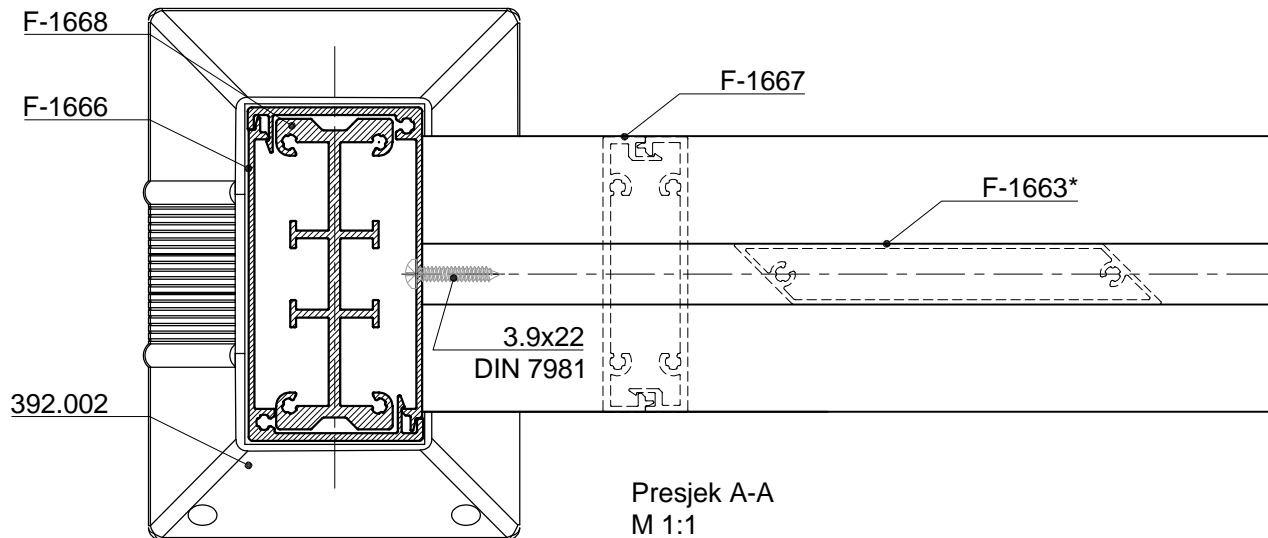
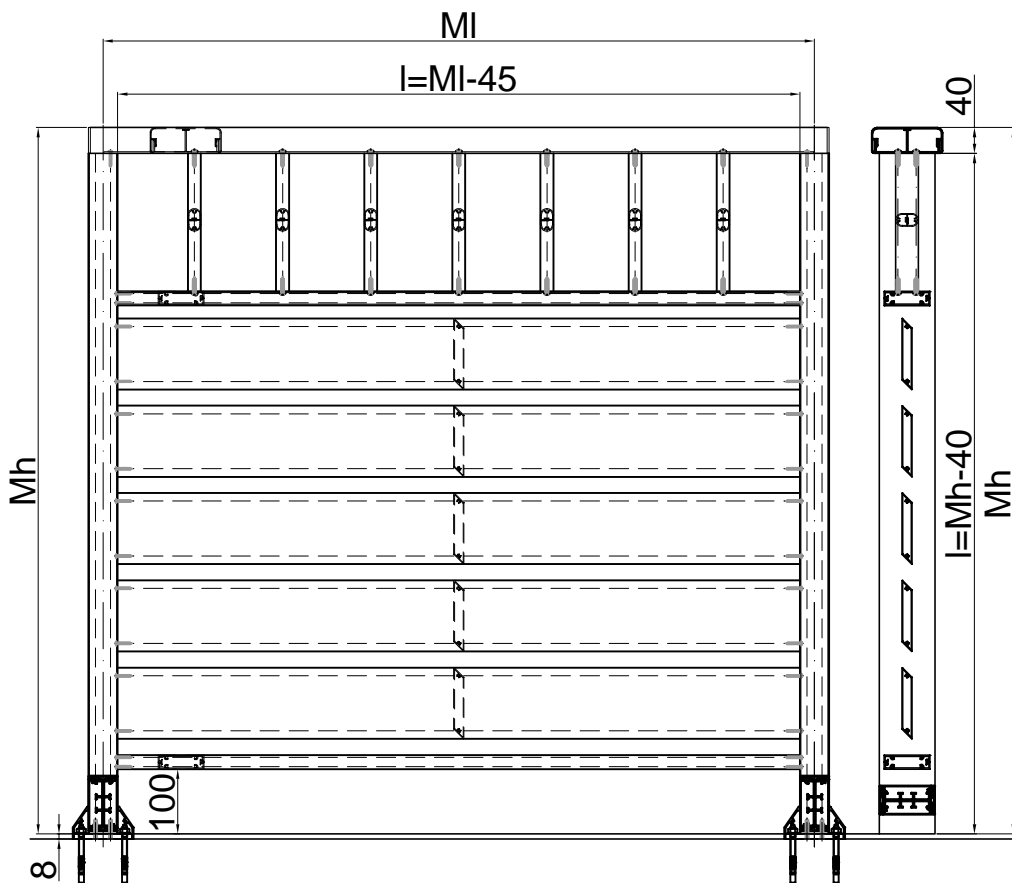

M 2:1

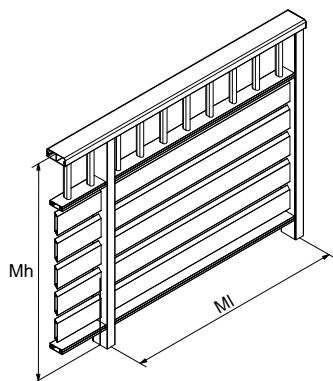

### OF-80 Tip A-45

npr.: za  $Mh=1092$  mm i  $MI=1100$  mm

#### 1. Postupak pilanja profila F-1667 i F-1663:

- 1.1. Podesiti pilu za pilanje na mjeru  $L=MI-45$
- 1.2. Profile F-1663 i F-1667 ispilati na mjere  $L=MI-45$
- 1.3. Podesiti pilu na pilanje na mjeru  $L=MI-2$
- 1.4. Profil F-1097 izrezati na mjeru  $L=MI-2$
- 1.5. Podesiti pilu na pilanje na mjeru  $L=Mh-40$
- 1.6. Profile F-1666 ispilati na mjere  $L=Mh-40$

F-1667 kom:4 x br. segmenata

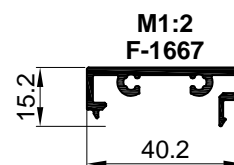
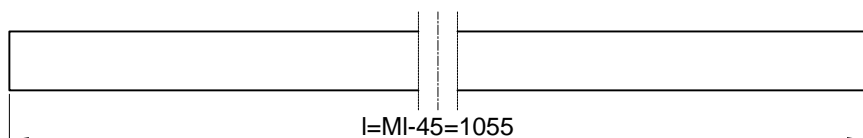

F-1663 kom:5 x br. segmenata

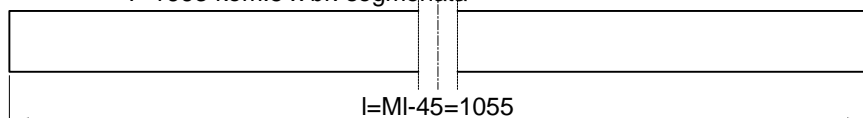

F-1097 kom:1 x br. segmenata

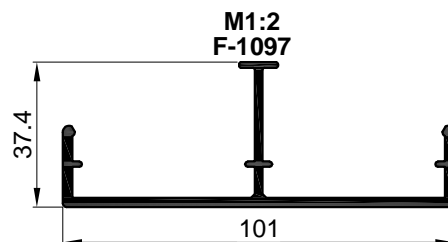
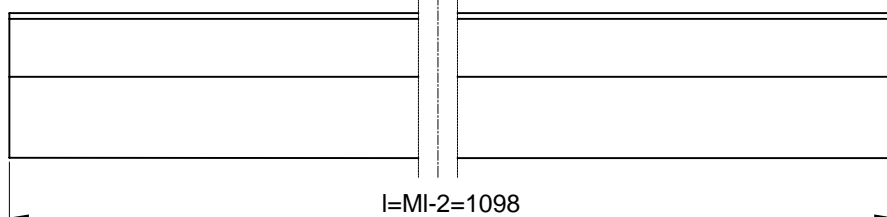

F-1666 kom:2 x br. segmenata

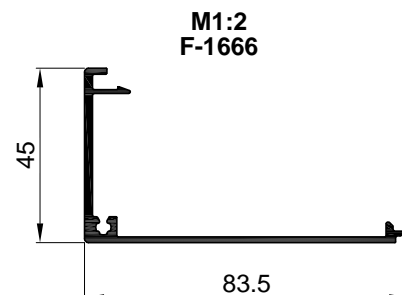
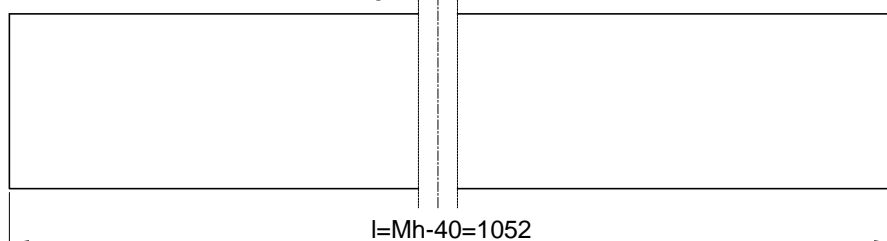

#### Napomena:

Iz jednog podešavanja pile, sve profile F-1663 i F-1667 ispilati na podešenu dužinu  $L=MI-45$

Iz jednog podešavanja pile, profil F-1097 ispilati na podešenu dužinu  $L=MI-2$

Ukoliko postoji više segmenata sve navedene profile ispilati iz jednog podešavanja pile prema dimenzijama

### OF-80 Tip A-86 - neparni segment

#### 2. Postupak bušenja profila F-1666:

- 2.1. Spojiti profile prema skici "A" i pomoću pripadajućeg šablona izbušiti rupe  $\varnothing 4$

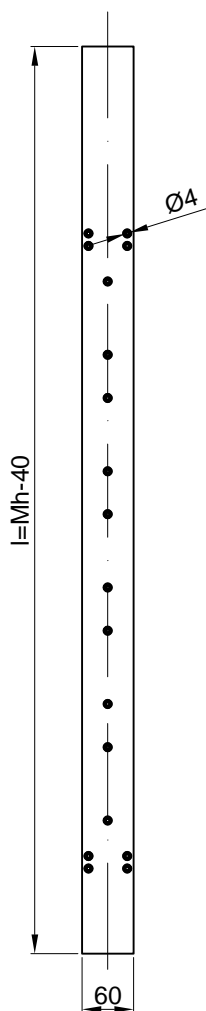
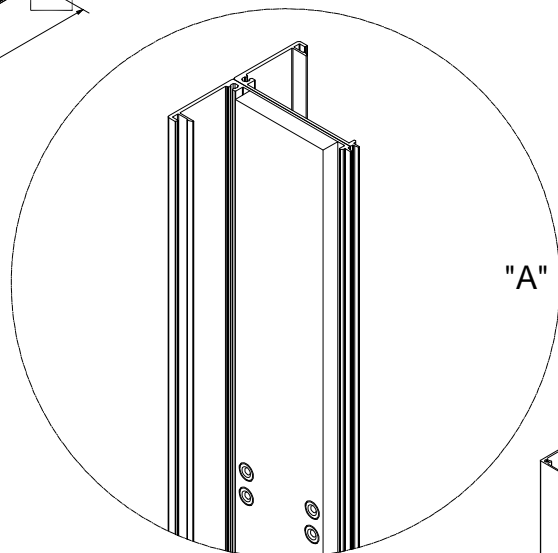
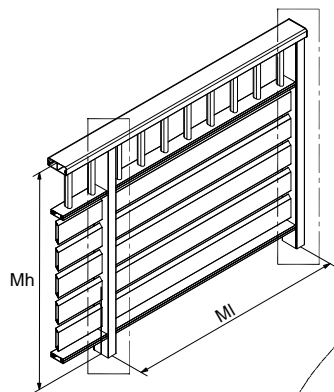

Šablon

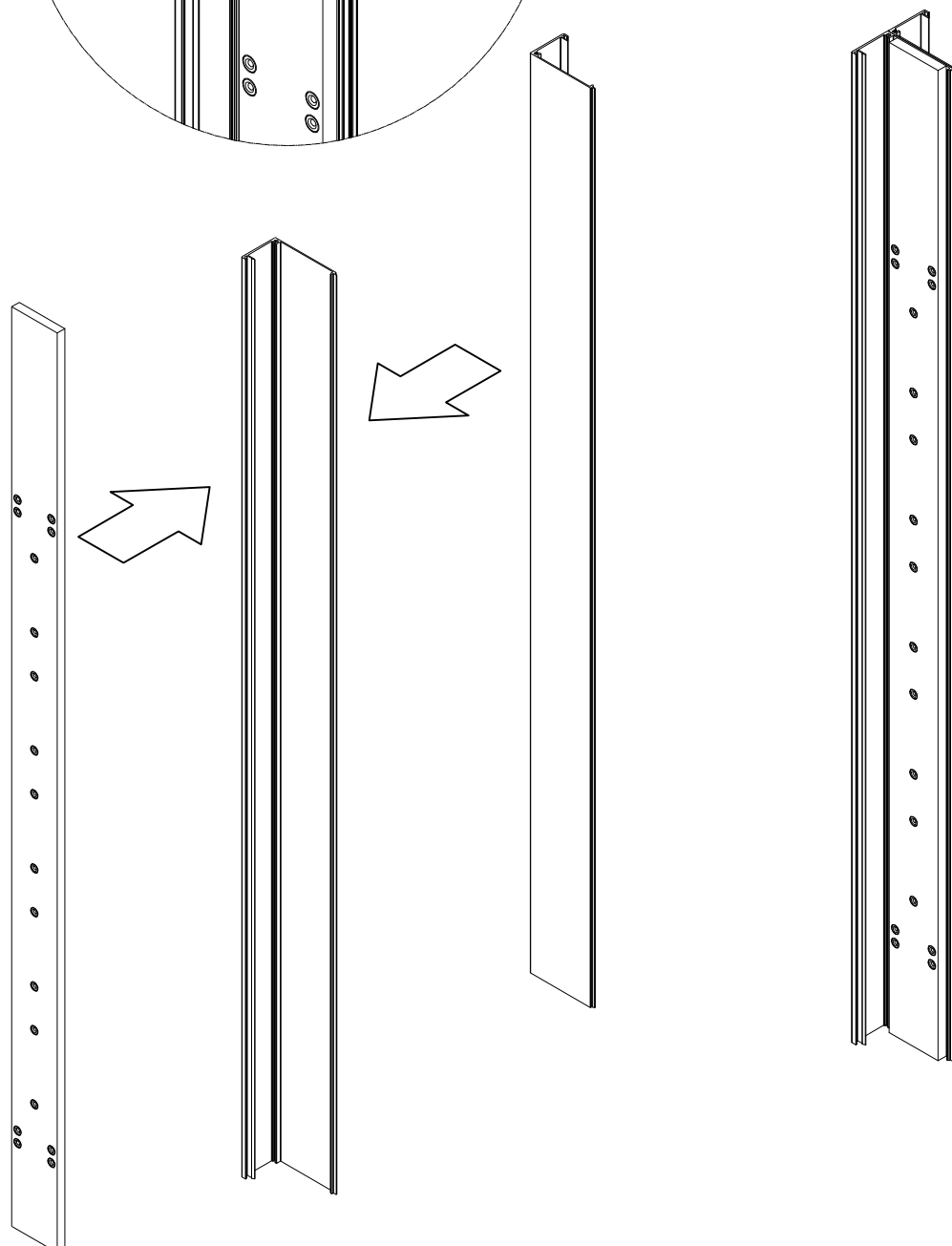

#### OF-80 Tip A-86 - parni segment

#### 3. Postupak bušenja profila F-1666:

- 3.1. Spojiti profile prema skici "A" i pomoću pripadajućeg šablona izbušiti rupe  $\varnothing 4$

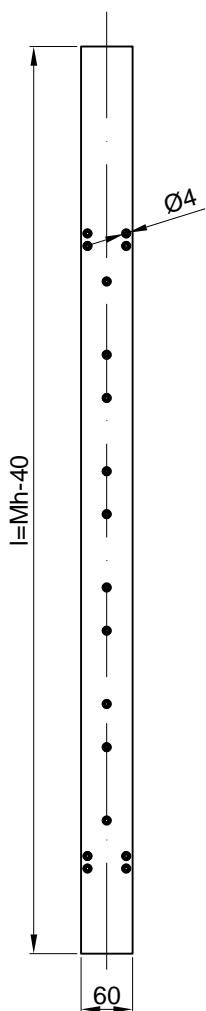
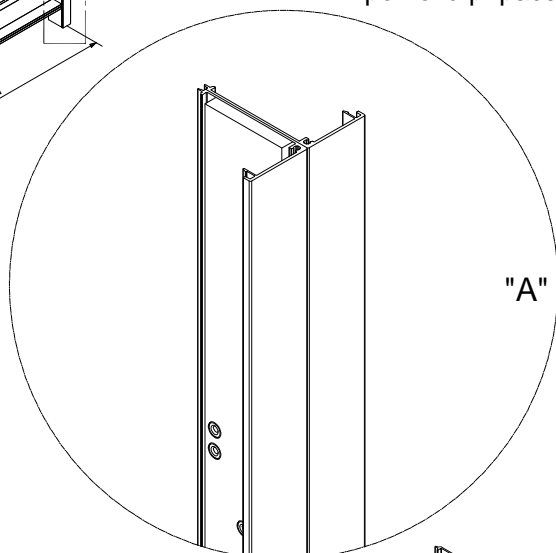
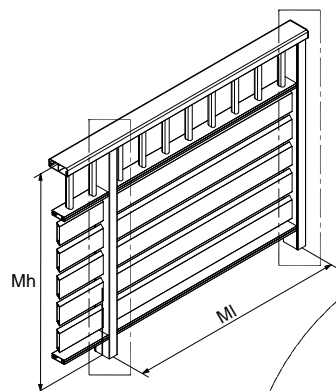

Šablon

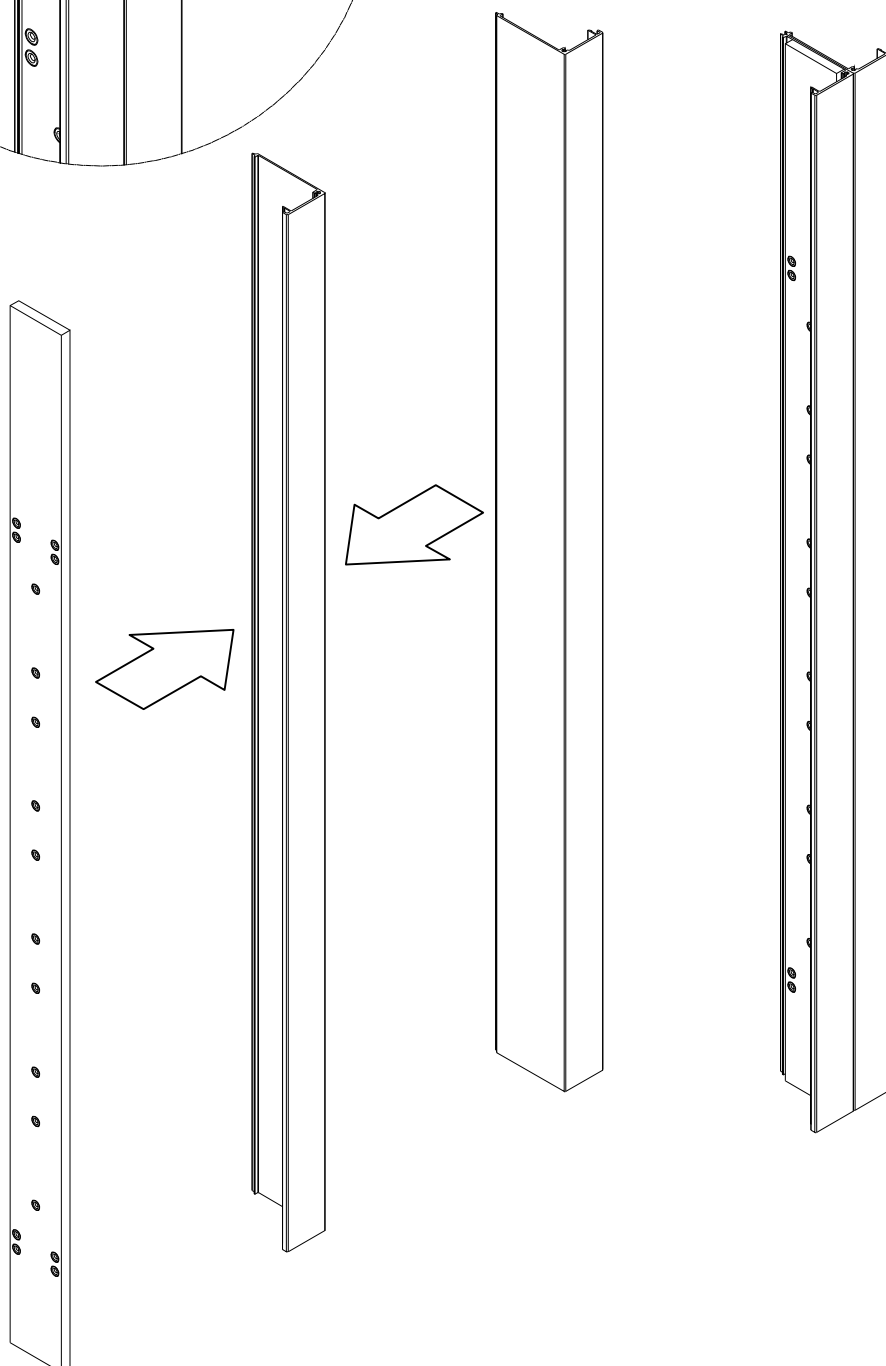

#### OF-80 Tip A-86 - neparni segment

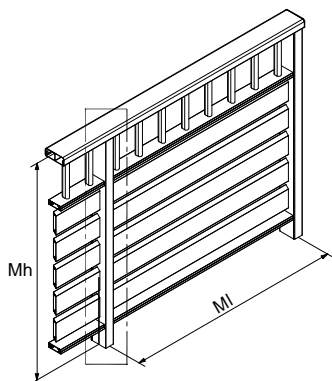

#### 4. Postupak spajanja profila F-1663, F-1666 i F-1667:

4.1. Profile F-1663 i F-1667 pričvrstiti za profil F-1666 vijcima 433.020 (3.9x22 DIN 7981)

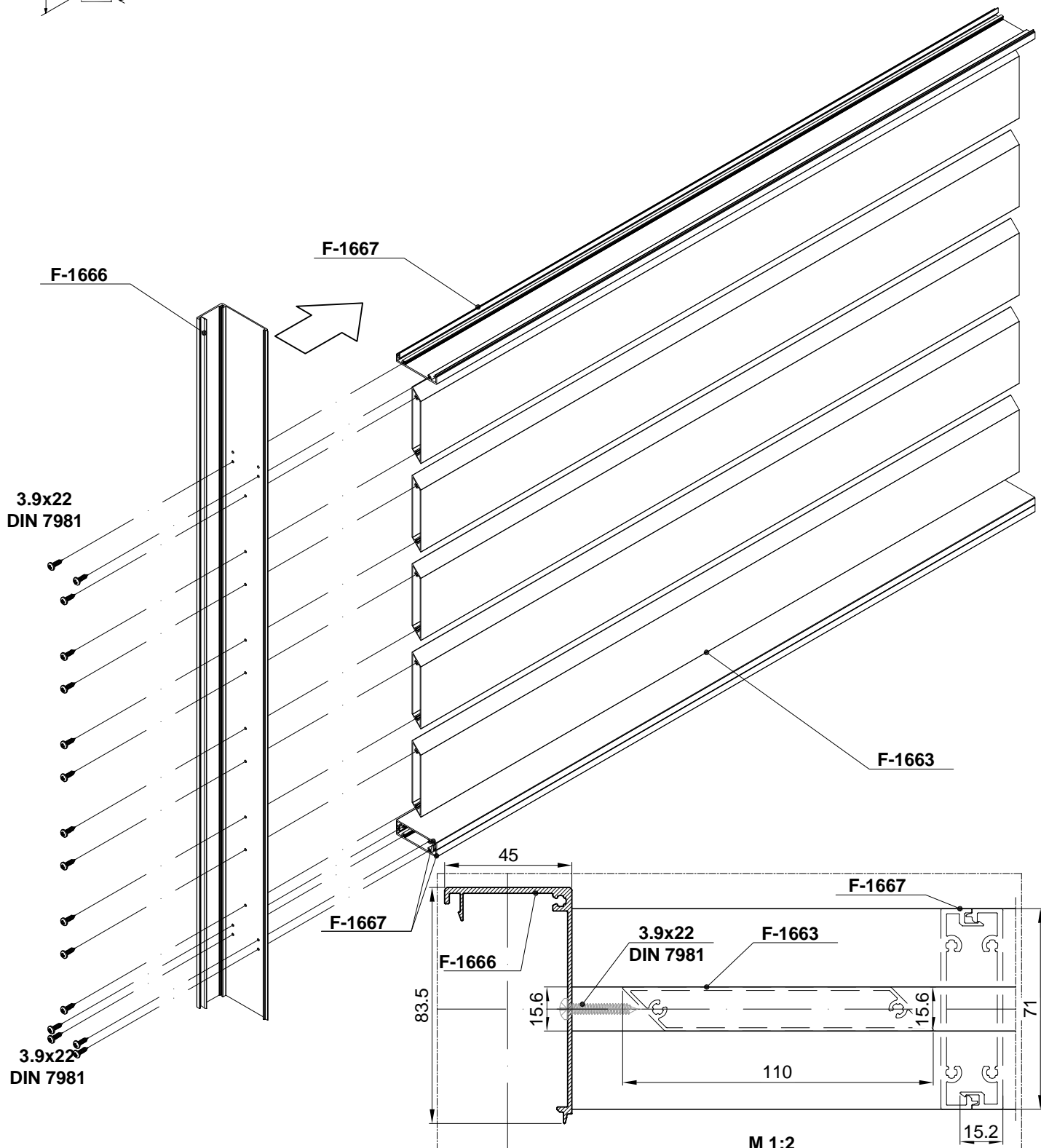

### OF-80 Tip A-86 - parni segment

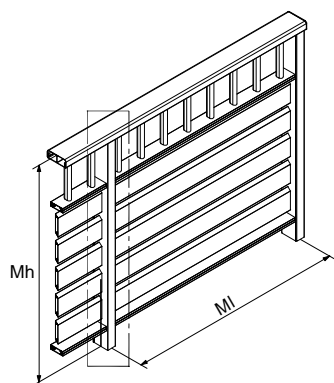

#### 5. Postupak spajanja profila F-1663, F-1666 i F-1667:

5.1. Profile F-1663 i F-1667 pričvrstiti za profil F-1666 vijcima 433.020 (3.9x22 DIN 7981)

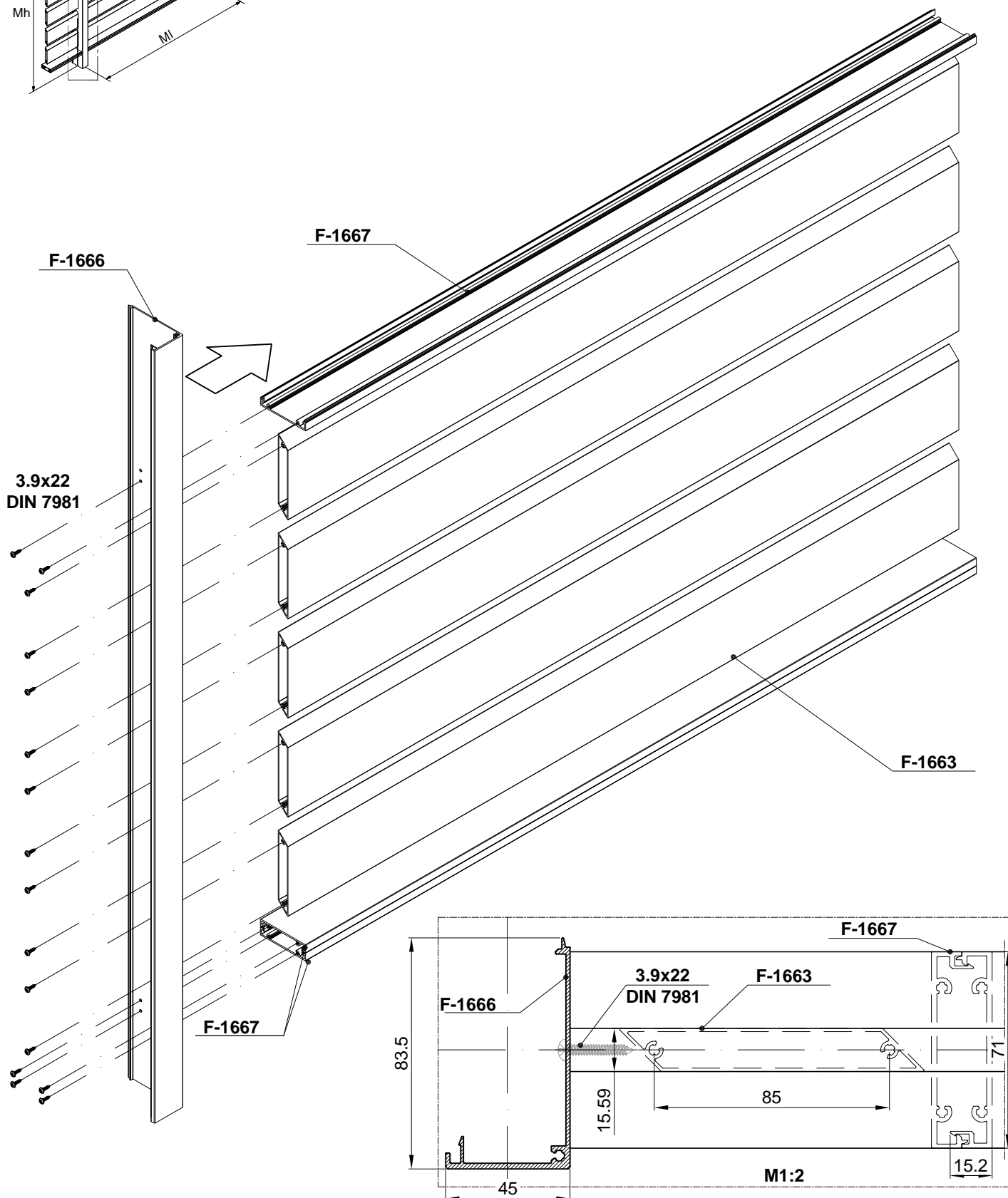

### OF-80 Tip A-86 - neparni segment

#### 6. Postupak spajanja profila F-1663, F-1666 i F-1667:

6.1. Profile F-1663 i F-1667 pričvrstiti za profil F-1666 vijcima 433.020 (3.9x22 DIN 7981)

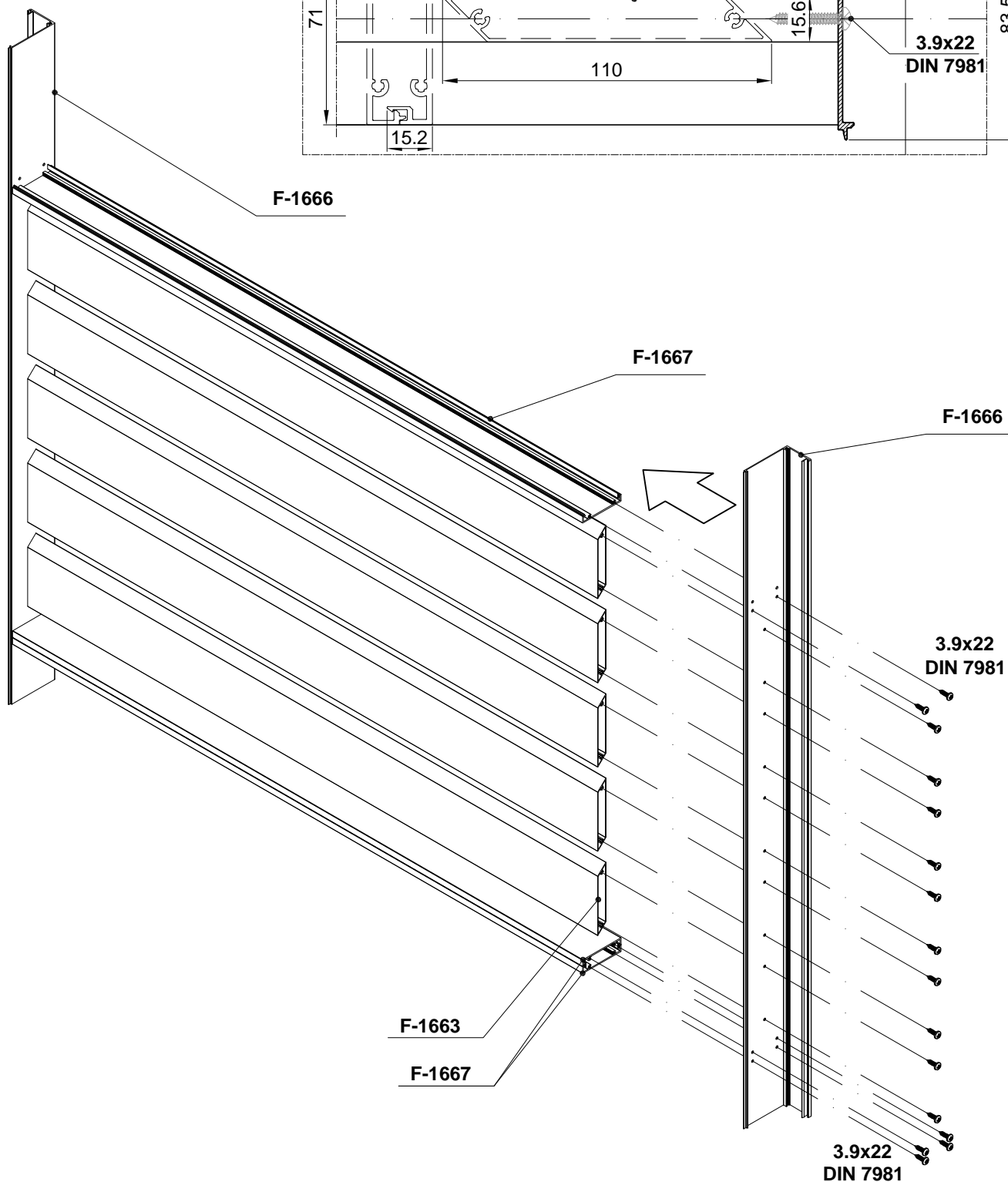
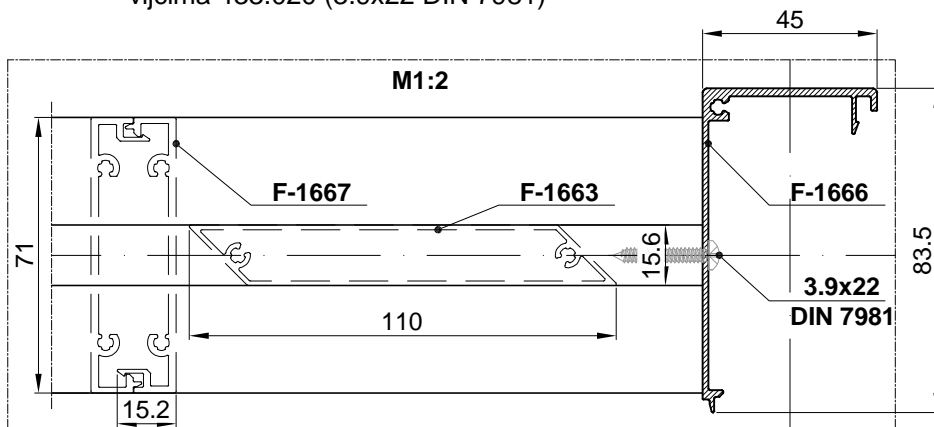
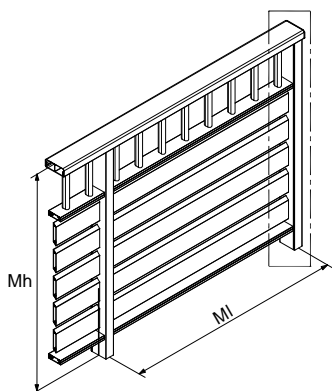

### OF-80 Tip A-86 - parni segment

#### 7. Postupak spajanja profila F-1663, F-1666 i F-1667:

##### 7.1. Profile F-1663 i F-1667 pričvrstiti za profil F-1666 vijcima 433.020 (3.9x22 DIN 7981)

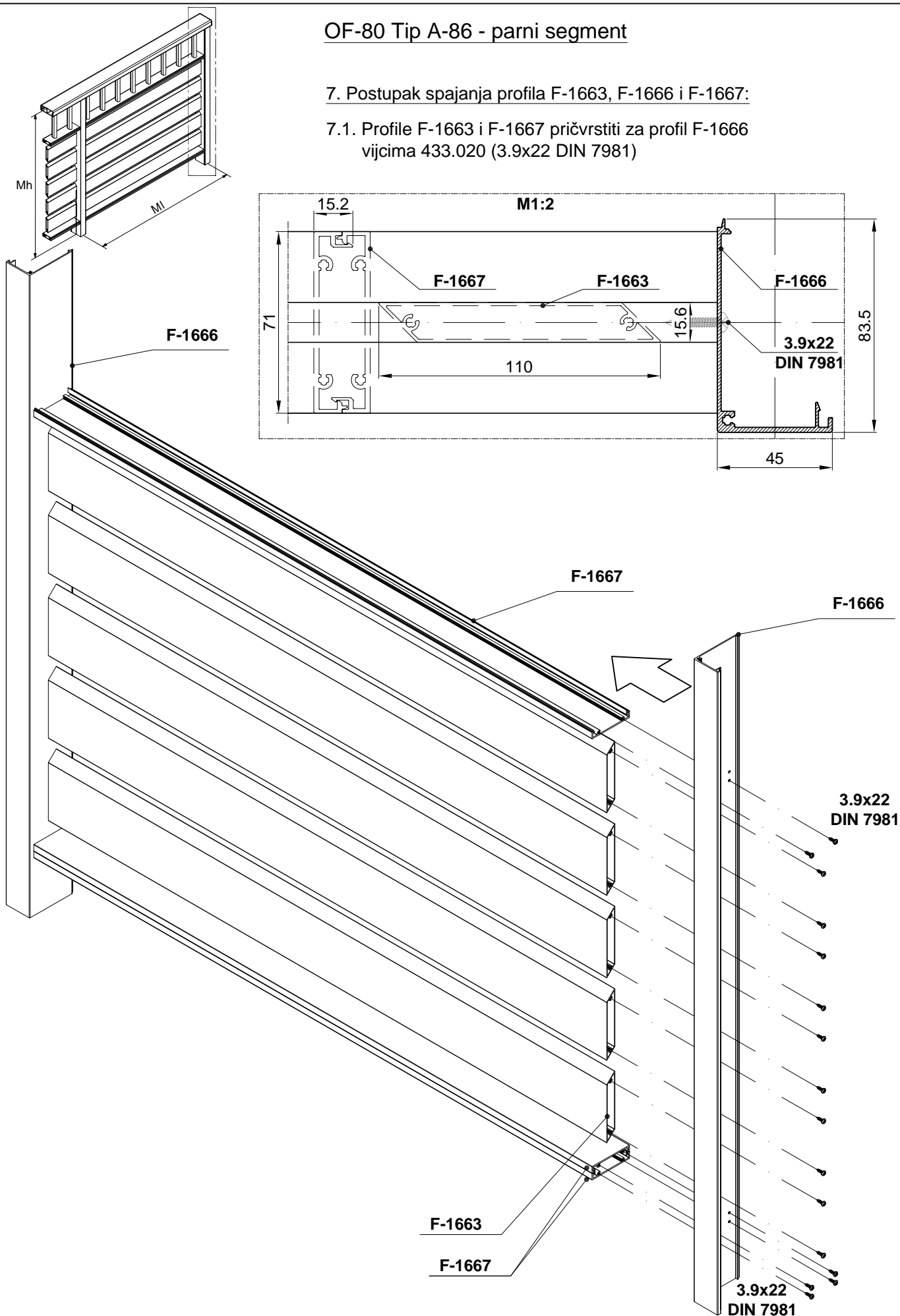

### OF-80 Tip A-86

#### 8. Postupak obrade profila F-1667 i F-1097:

- 8.1. Na profilu F-1667 napraviti rupe  $\varnothing 5$
- 8.2. Na profilu F-1097 napraviti rupe  $\varnothing 4$  i  $\varnothing 5$

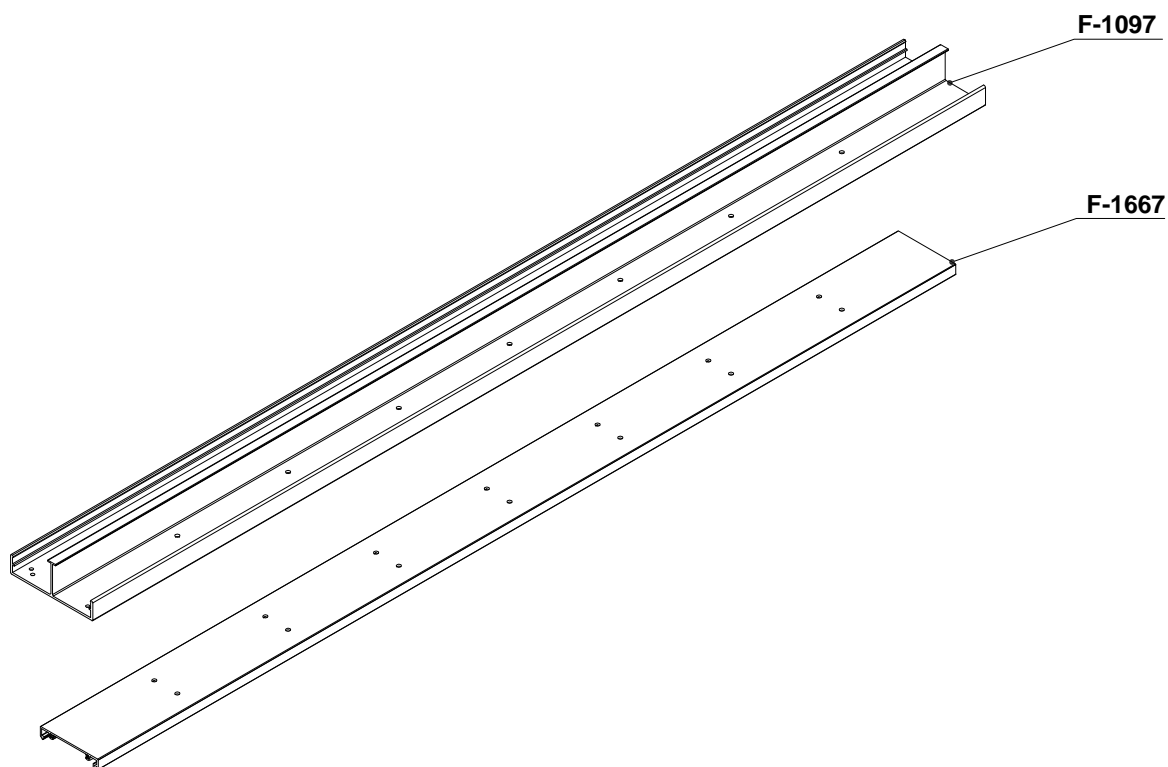
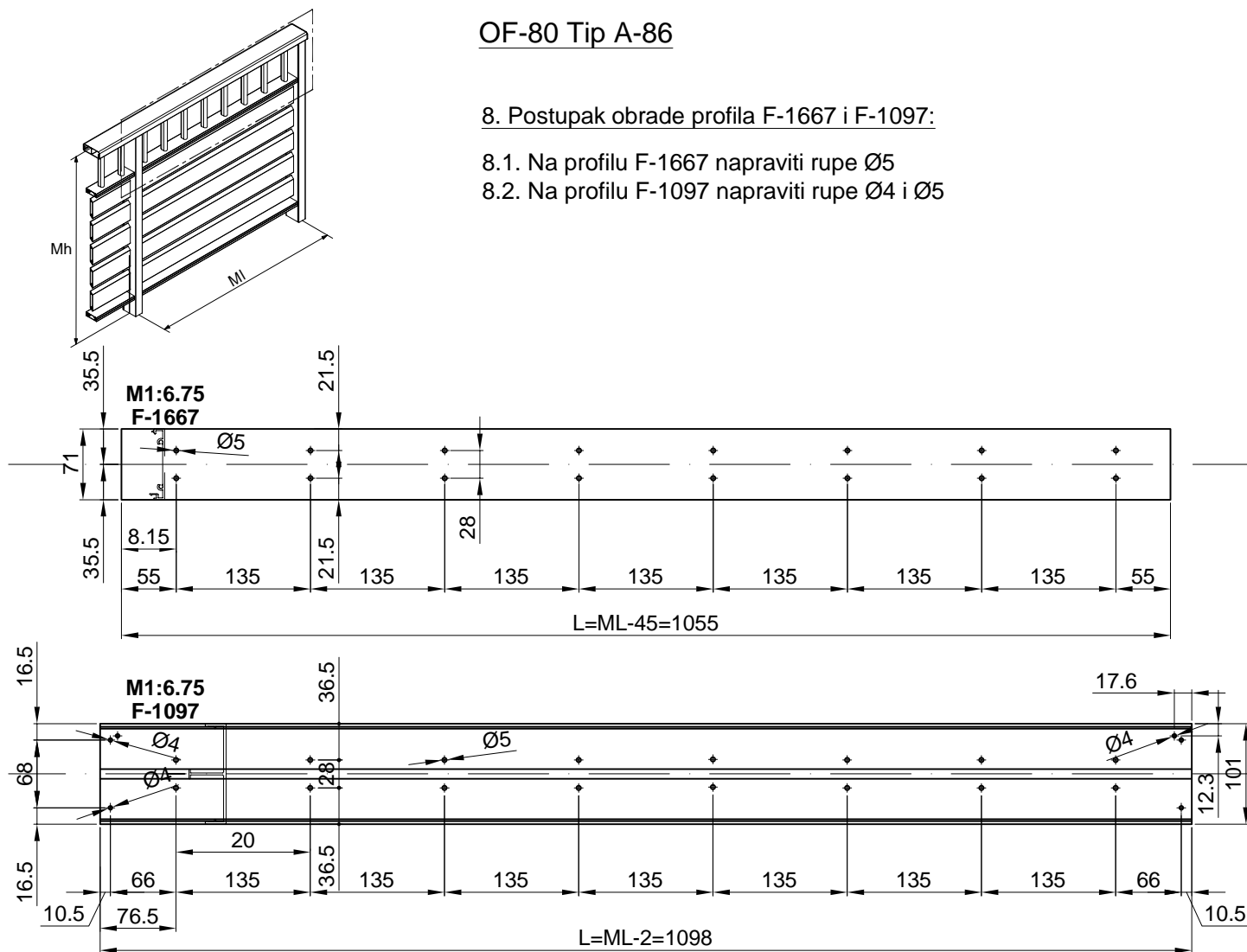

### OF-80 Tip A-86 - neparni segment

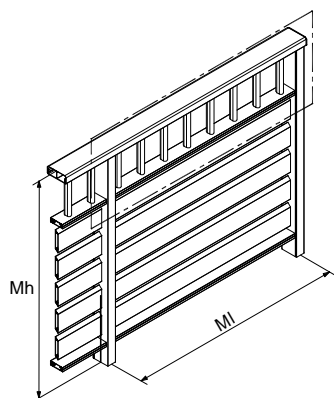

#### 9. Postupak spajanja profila F-1667, F-1097 i OG-111:

- 9.1. Profile OG-111 ispilati na visinu 213 mm.
- 9.2. Na profil F-1667 pričvrstiti profile OG-111 vijcima 433.031 (4.2x22 DIN 7981)
- 9.3. S gornje strane pričvrstiti profil F-1097 vijcima 433.031 (4.2x22 DIN 7981)

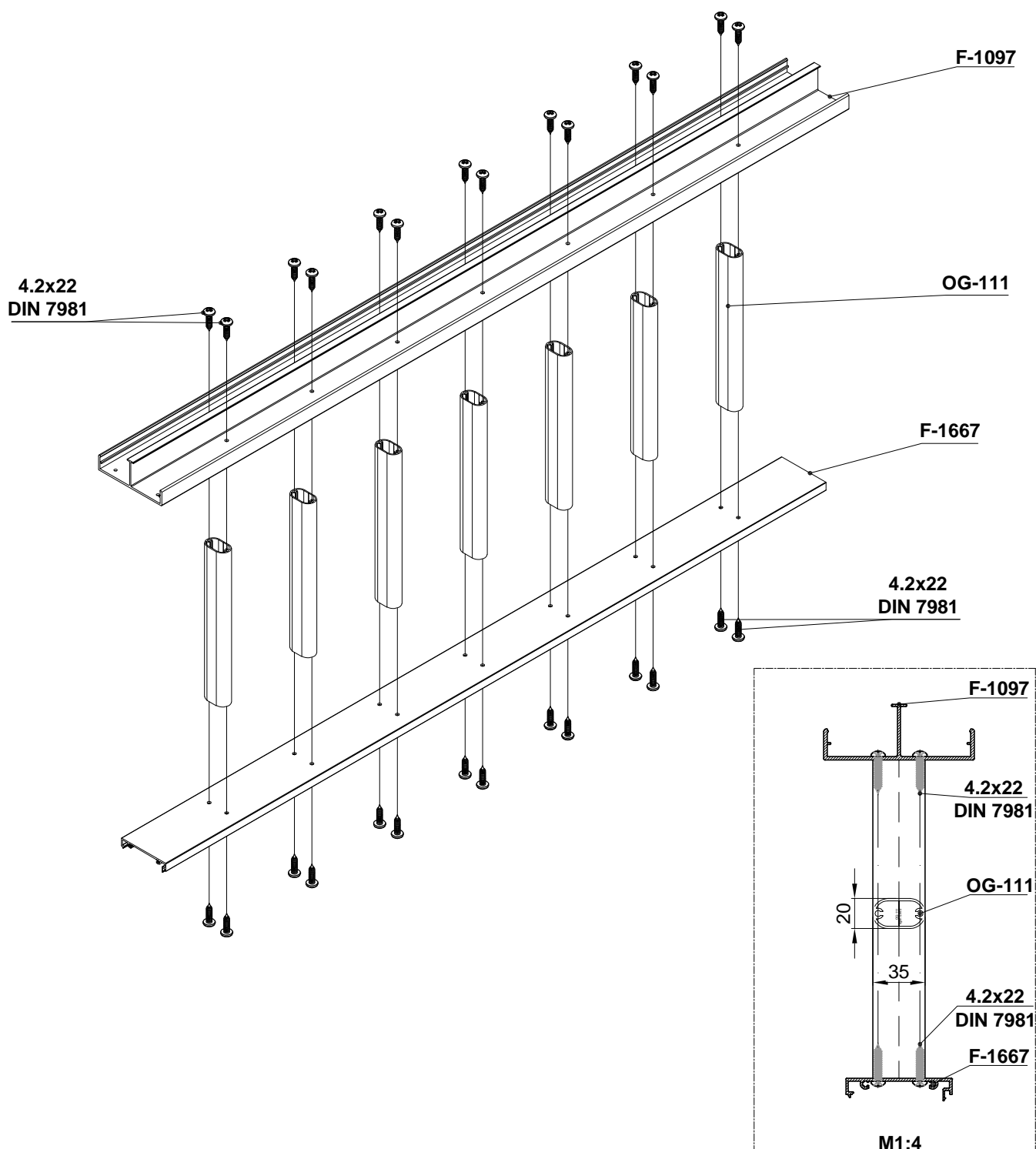

### OF-80 Tip A-86 - neparni segment

10. Postupak spajanja gornjeg dijela segmenta s donjim segmentom:

10.1. Gornji dio segmenta postaviti između vertikalnih profila F-1666, zatim ih pričvrstiti vijcima 433.108 (3.9x22 DIN 7981)

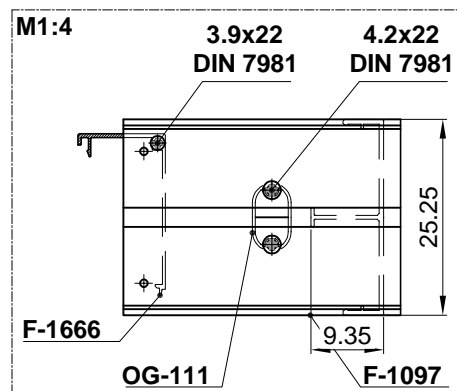
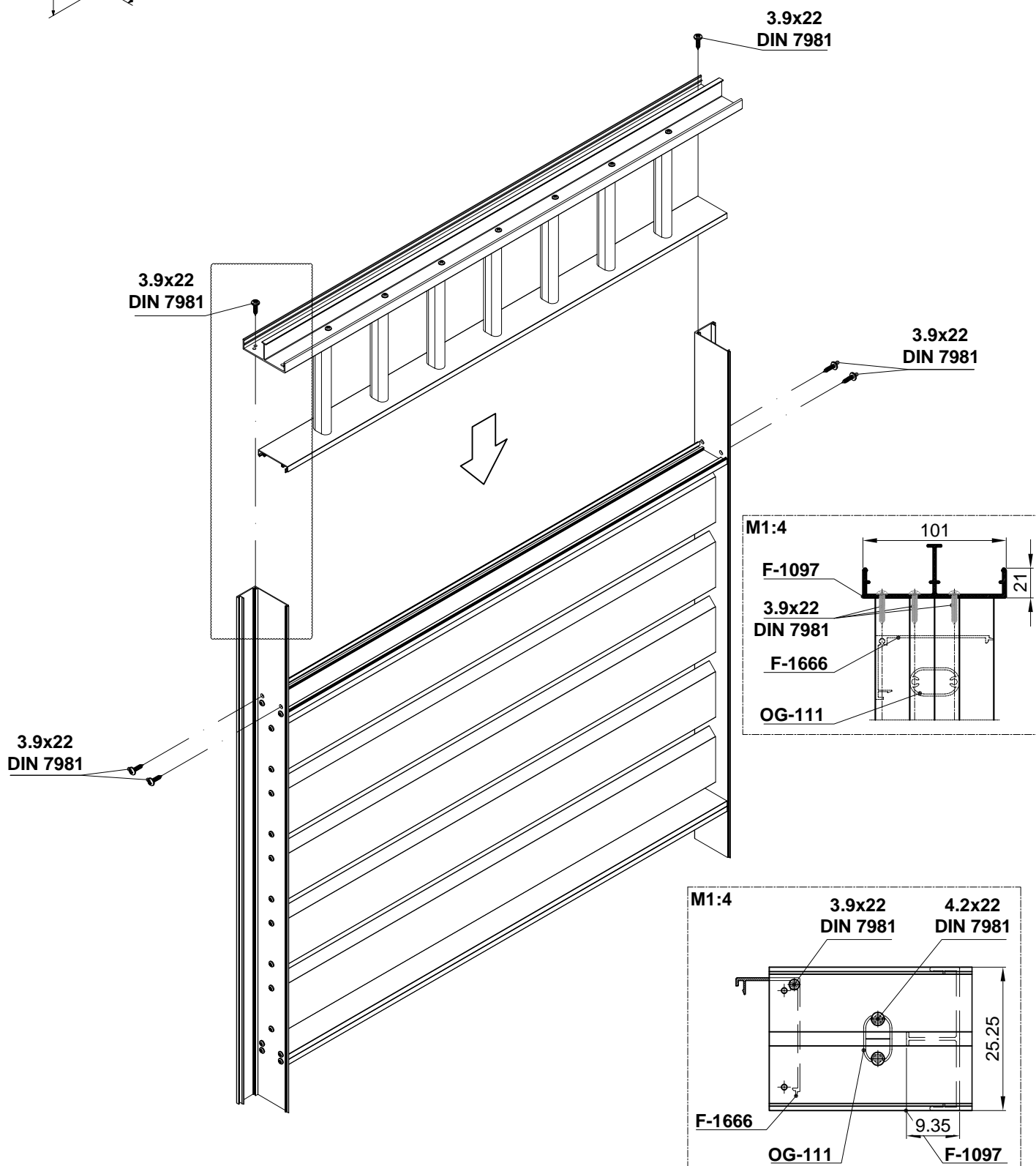
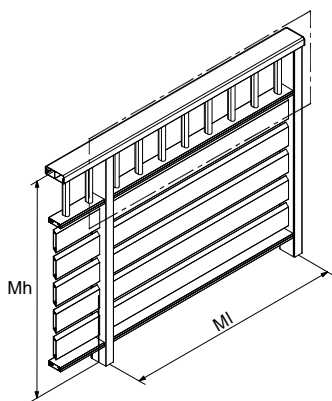

### OF-80 Tip A-86 - neparni segment

#### 11. Neparni segment OF-80 tipa A:

M1:5

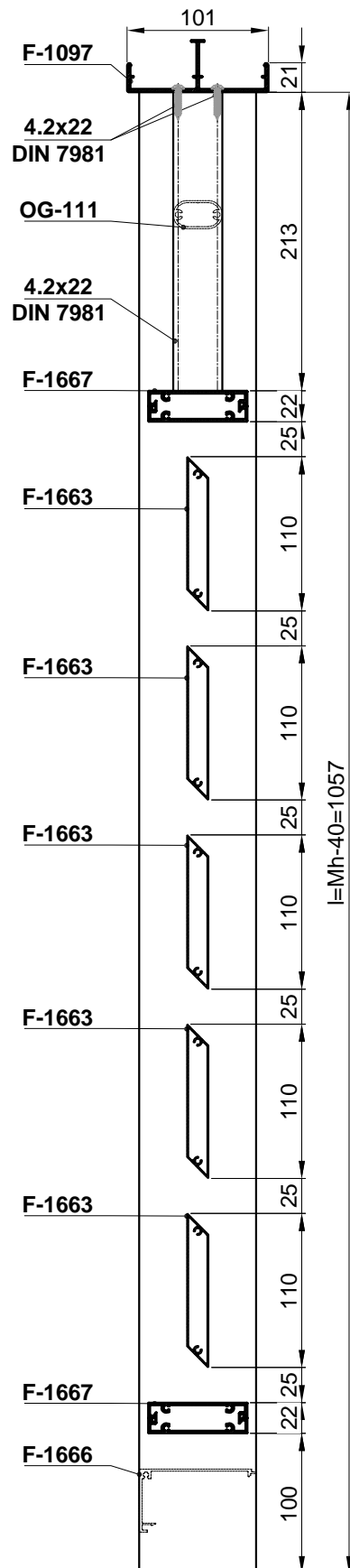
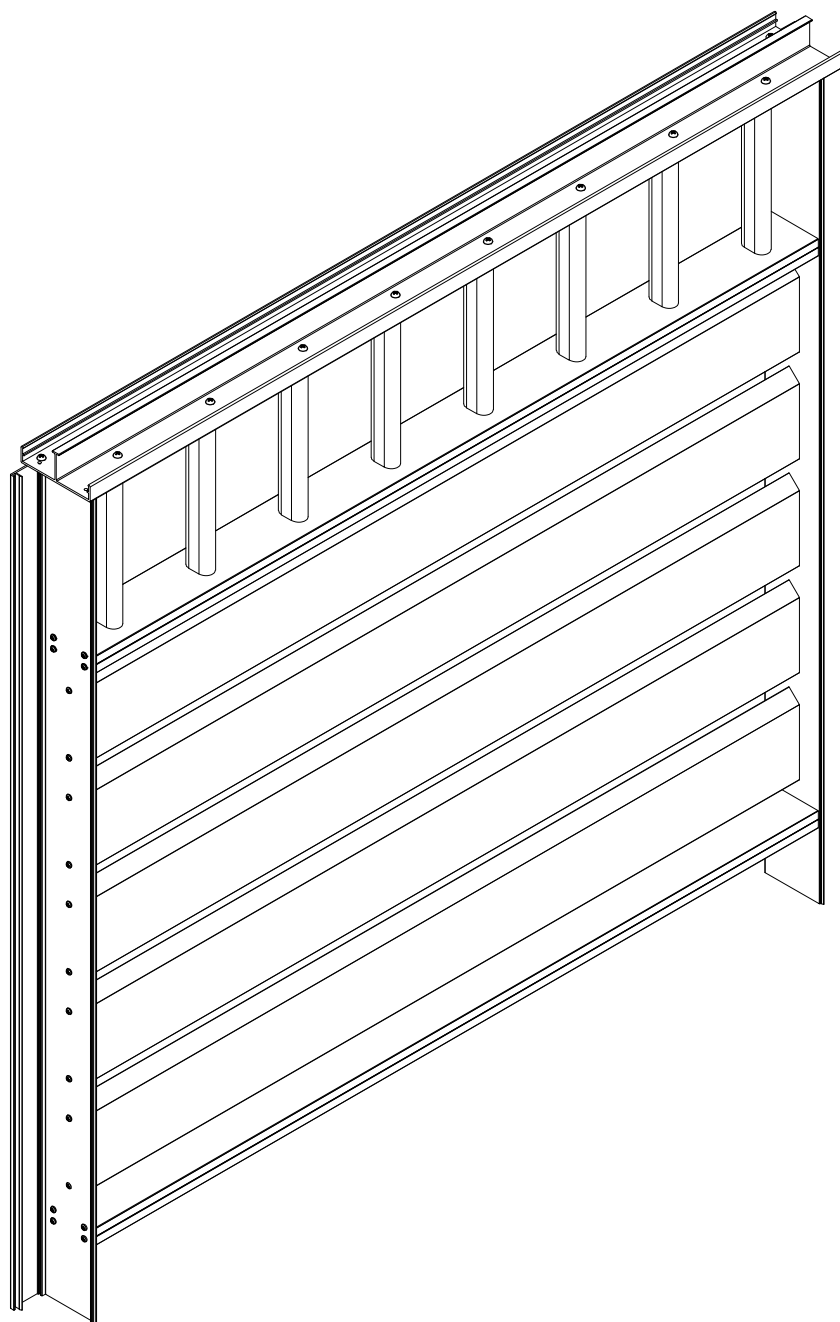
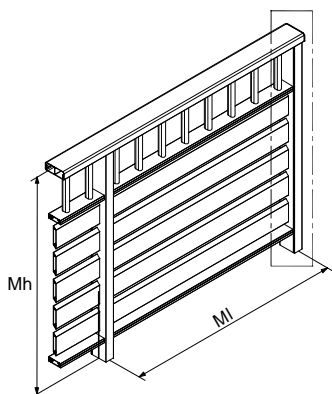

### OF-80 Tip A-86 - parni segment

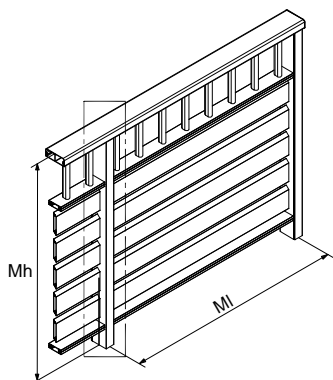

12. Postupak spajanja gornjeg dijela segmenta s donjim segmentom:

12.1. Gornji dio segmenta postaviti između vertikalnih profila F-1666, zatim ih pričvrstiti vijcima 433.108 (3.9x22 DIN 7981)

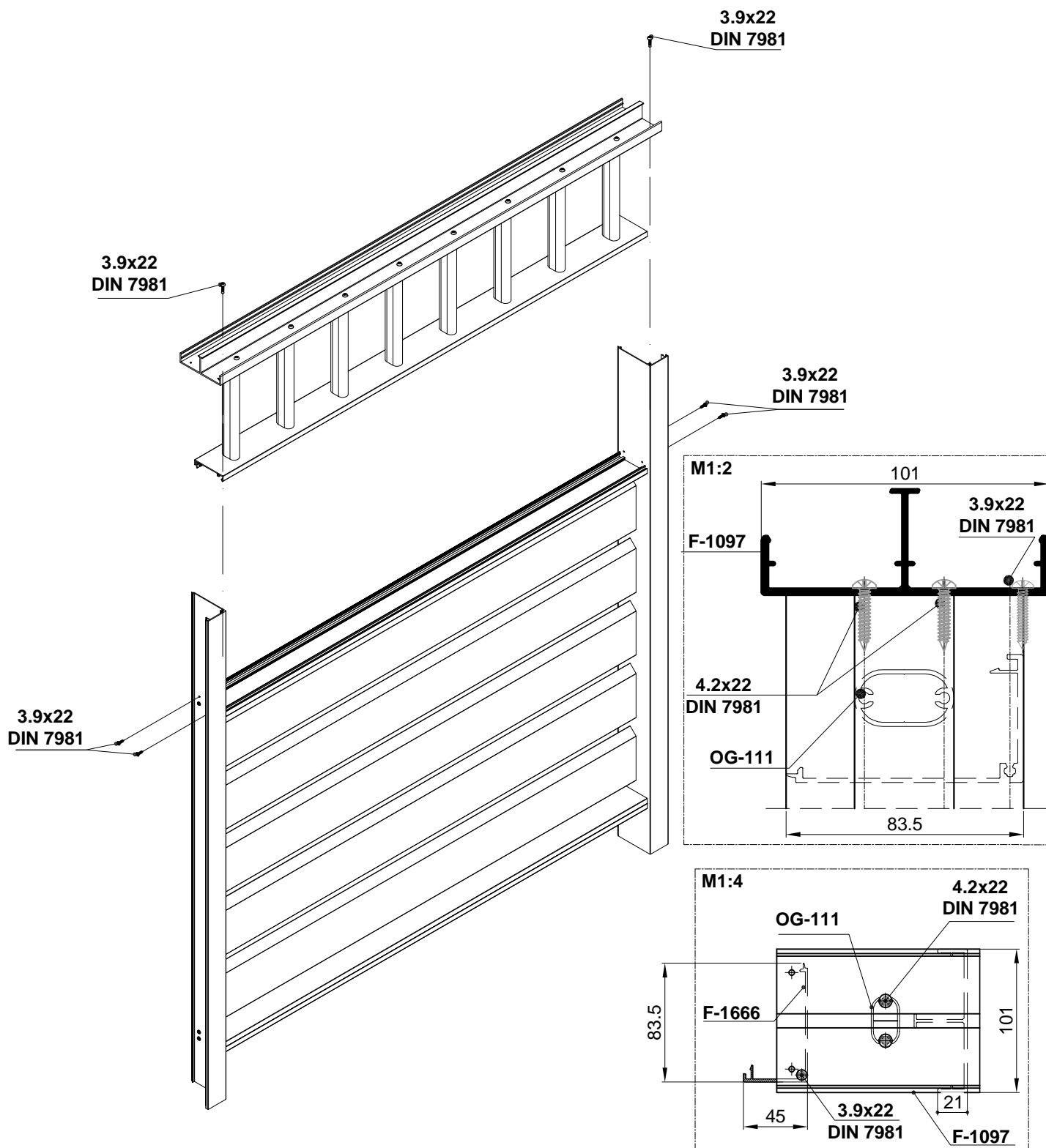

### OF-80 Tip A-86 - parni segment

13. Parni segment OF-80 tipa A:

M1:5

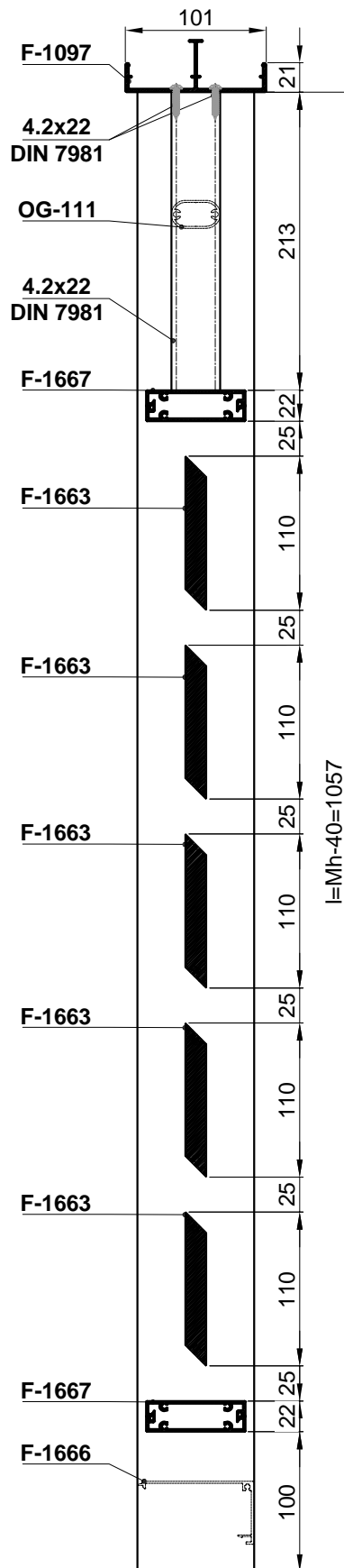
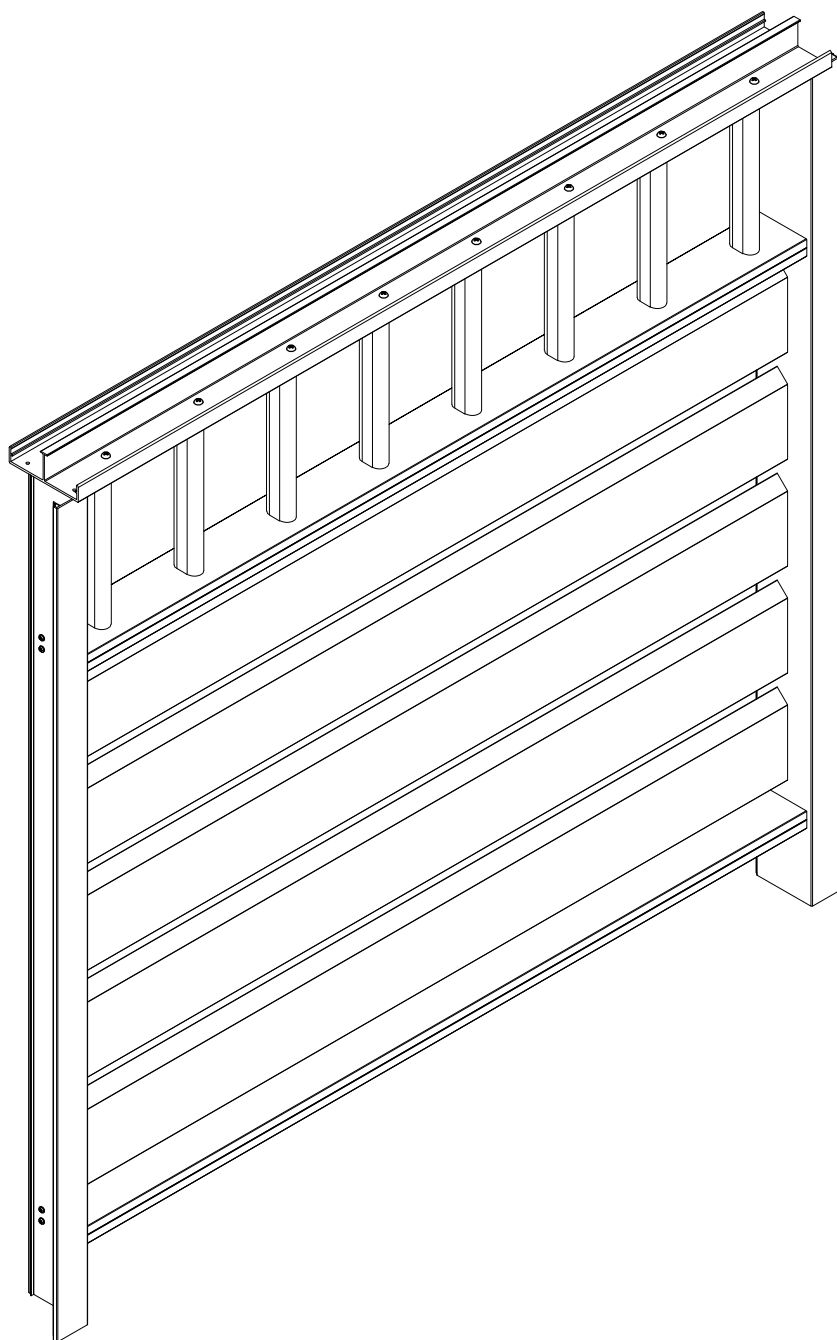
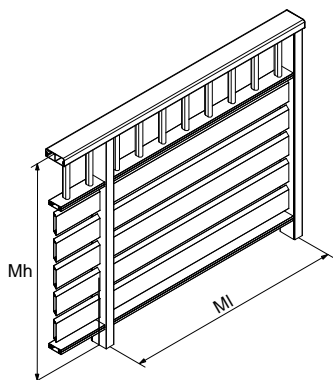

#### OF-80 Tip A-86

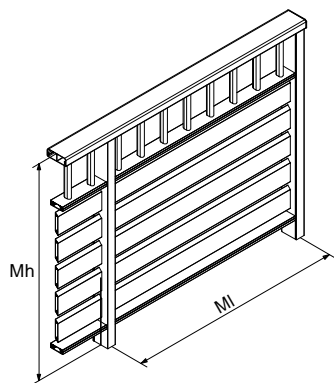

#### 14. Montaža segmenata OF-80 tipa A:

- 14.1. Postavljamo neparni segment kapije OF-80 Tip A-86, koje pričvršćujemo vijcima 433.108 (3.9x22 DIN 7981)
- 14.2. Postavljamo parni segment kapije OF-80 Tip A-86, koje pričvršćujemo vijcima 433.108 (3.9x22 DIN 7981)
- 14.3. Na dnu spojenih parnih i neparnih segmenata kapije OF-80 Tip A-86, postavljamo rozetu 392.002 koji pričvršćujemo vijcima M5x50

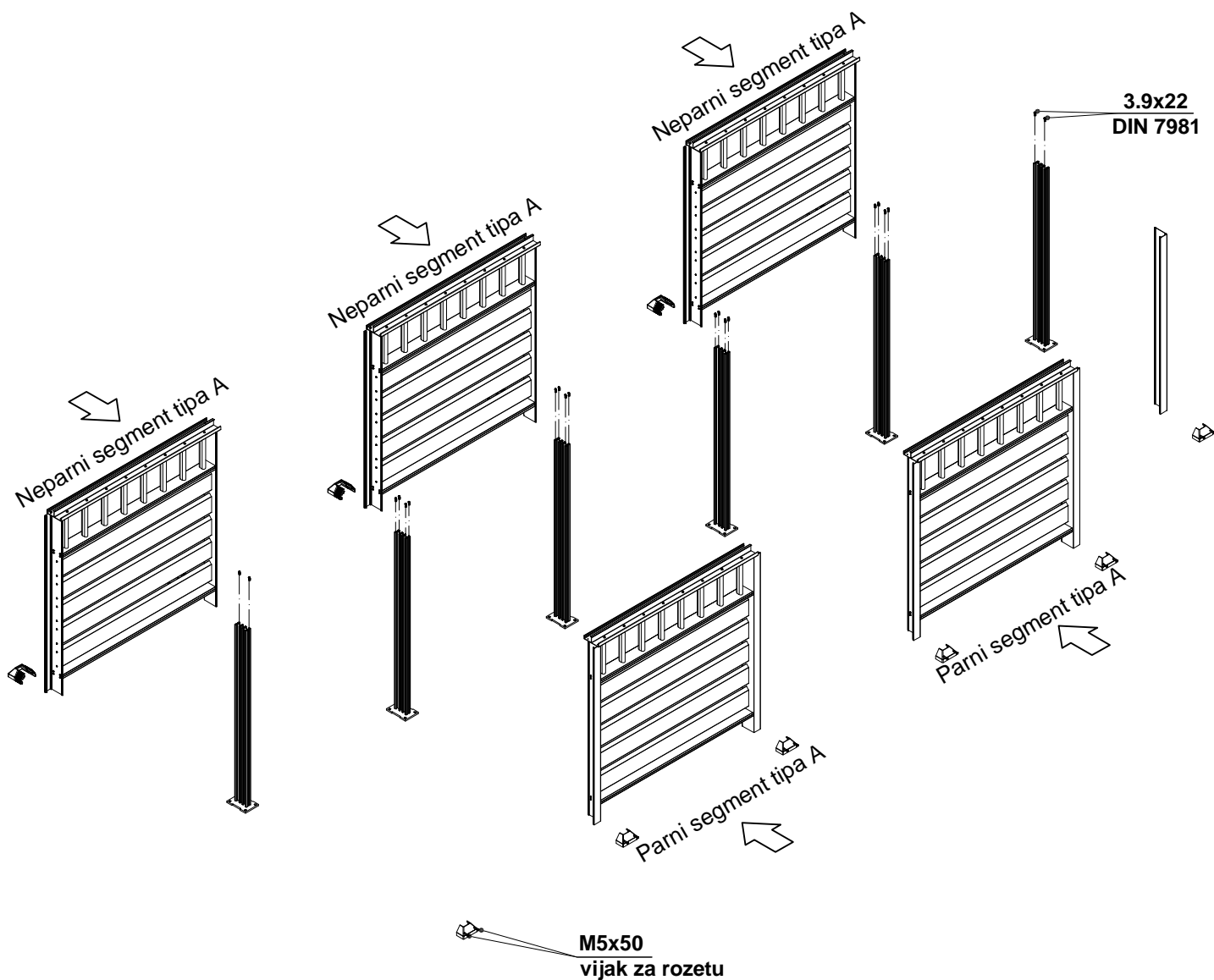

### OF-80 Tip A-86

#### 15. Montaža segmenata OF-80 tipa A:

15.1. Na sastavljene segmente kapije postavljamo rukohvat F-1096, na krajevima rukohvata postavljamo PVC čepove 391.204

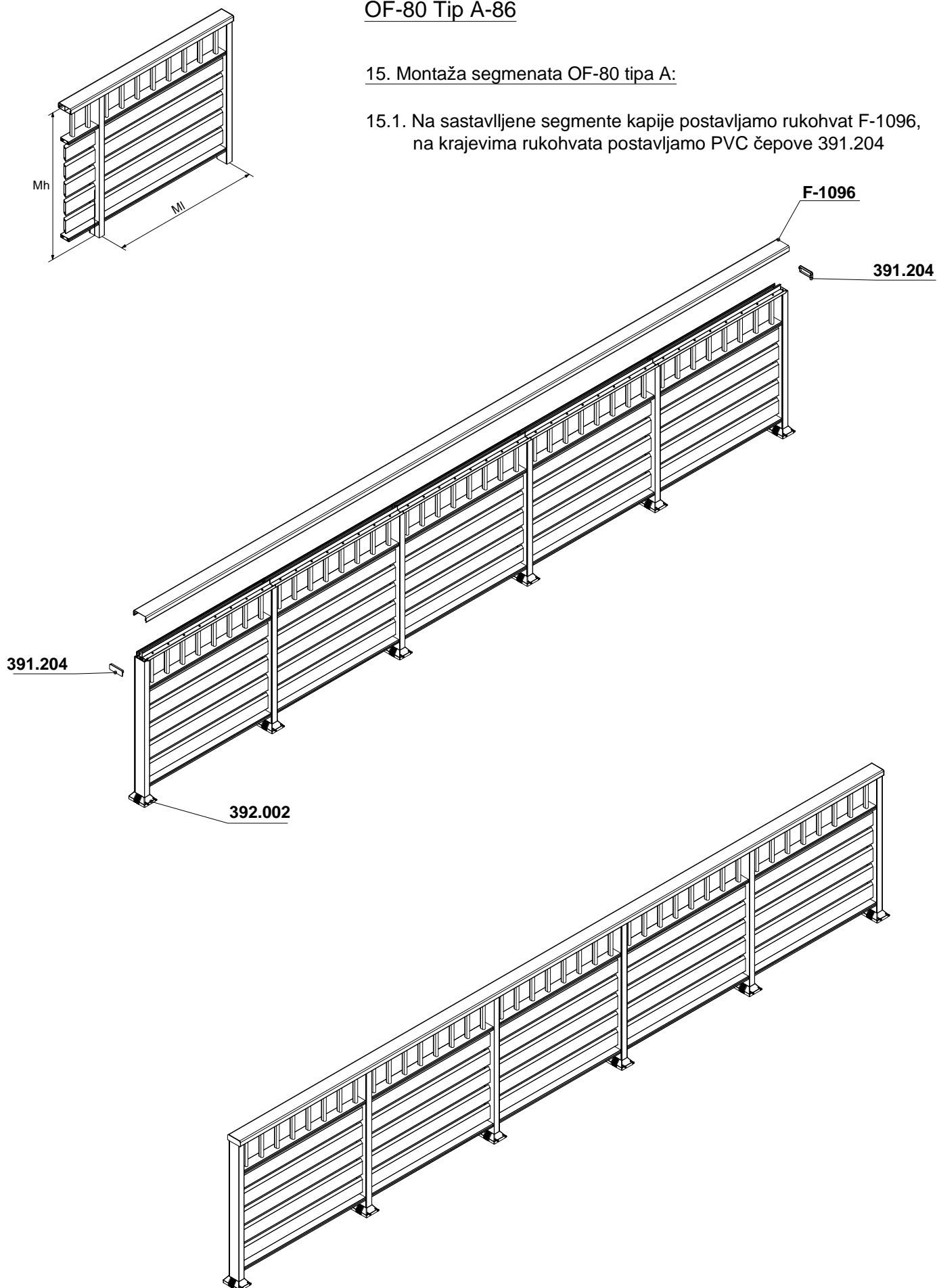



#### OF-80 Tip A-45

#### 1. Profili koji se koriste u segmentu:

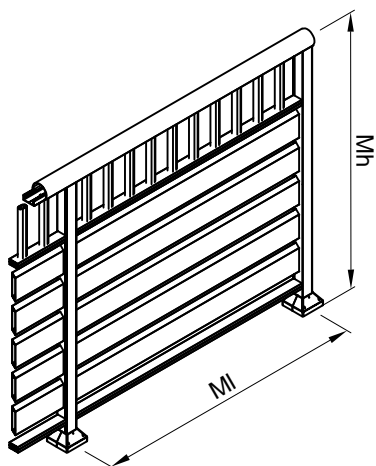

M 1:4

Profili segmenta	
F-1659 T=0.51kg/m	
F-1665 T=1.33kg/m	
F-1660 T=0.43kg/m	
F-0621 T=0.83kg/m	*
F-0620 T=0.60kg/m	
F-1663 T=0.83kg/m	*
OG-111 T=0.44kg/m	*

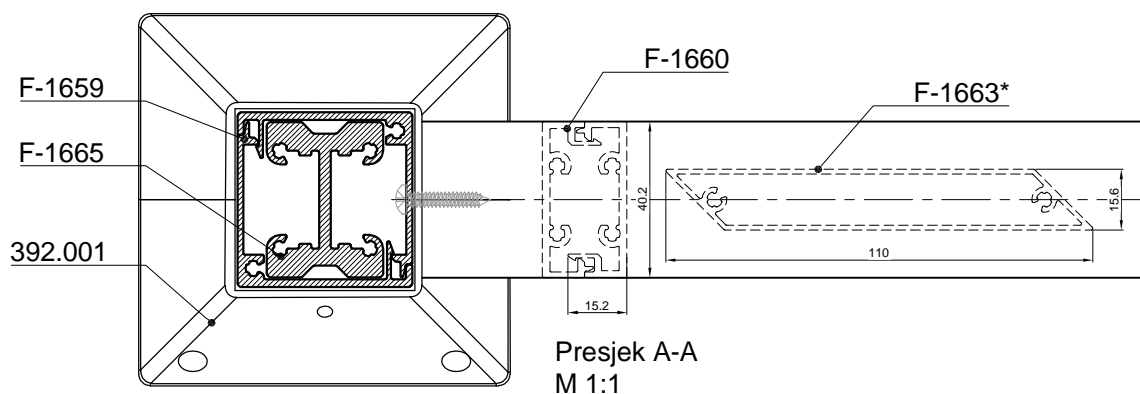
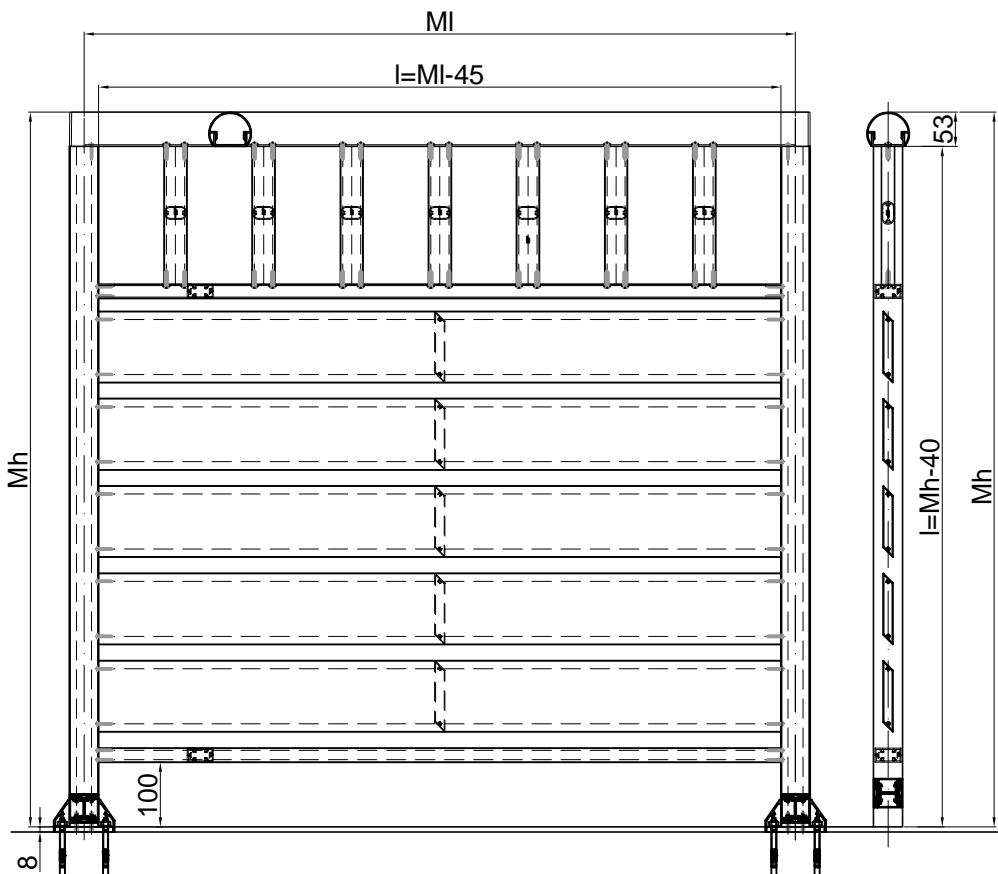

M 2:1

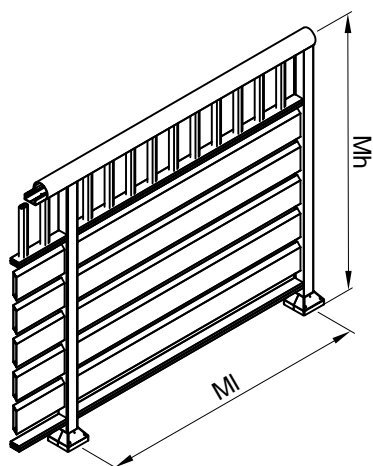

### OF-80 Tip A-45

npr.: za  $Mh=1092$  mm i  $MI=1100$  mm

#### 1. Postupak pilanja profila F-1660 i F-1663:

- 1.1. Podesiti pilu za pilanje na mjeru  $L=MI-45$
- 1.2. Profile F-1663 i F-1660 ispilati na mjere  $L=MI-45$
- 1.3. Podesiti pilu na pilanje na mjeru  $L=MI-2$
- 1.4. Profil F-0620 izrezati na mjeru  $L=MI-2$
- 1.5. Podesiti pilu na pilanje na mjeru  $L=Mh-53$
- 1.6. Profile F-1659 ispilati na mjere  $L=Mh-53$

F-1667 kom:4 x br. segmenata

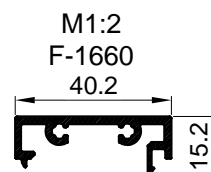
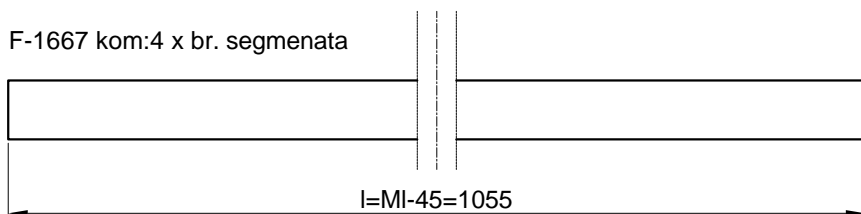

F-1663 kom:5 x br. segmenata

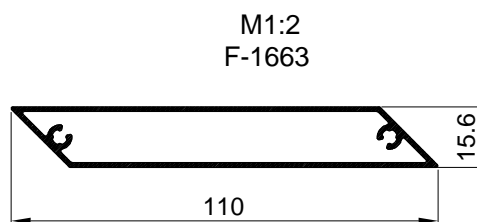
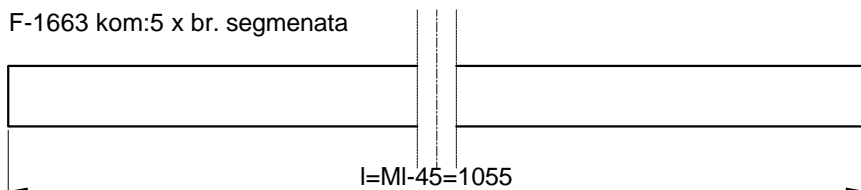

F-1097 kom:1 x br. segmenata

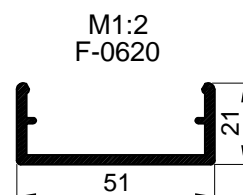
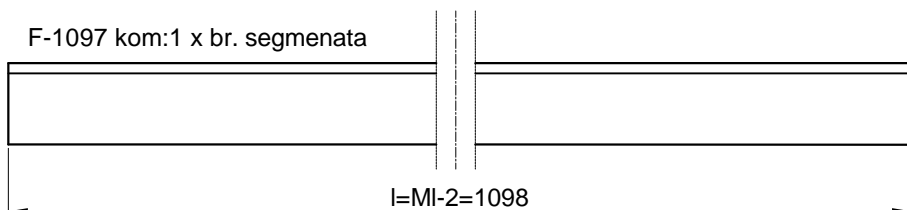

F-1666 kom:2 x br. segmenata

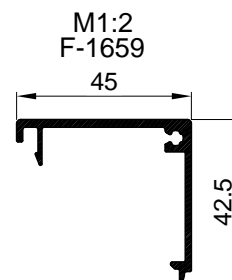
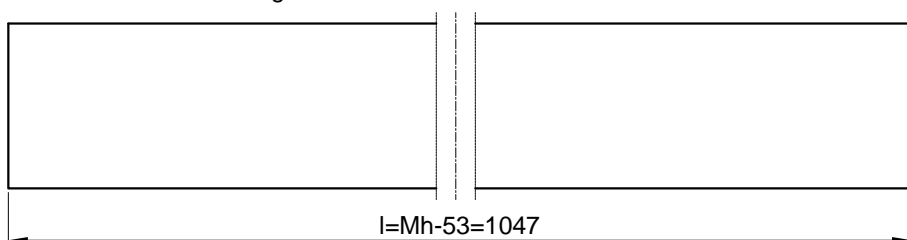

#### Napomena:

Iz jednog podešavanja pile, sve profile F-1663 i F-1660 ispilati na podešenu dužinu  $L=MI-45$

Iz jednog podešavanja pile, profil F-0620 ispilati na podešenu dužinu  $L=MI-2$

Ukoliko postoji više segmenata sve navedene profile ispilati iz jednog podešavanja pile prema dimenzijama

#### OF-80 Tip A-45 - neparni segment

##### 2. Postupak bušenja profila F-1659:

- 2.1. Spojiti profile prema skici "A" i pomoću pripadajućeg šablona izbušiti rupe  $\varnothing 4$

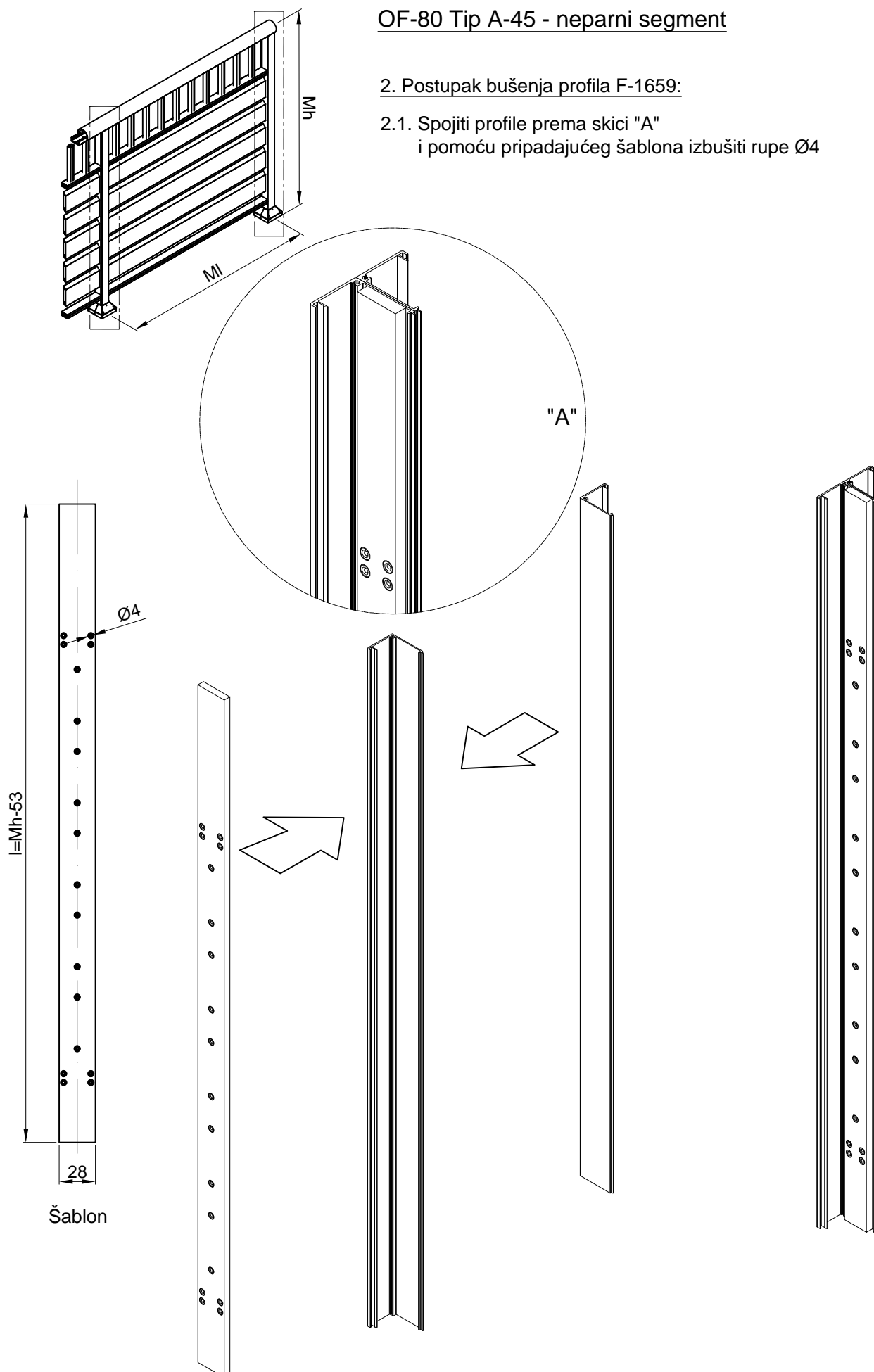

### OF-80 Tip A-45 - parni segment

#### 3. Postupak bušenja profila F-1659:

- 3.1. Spojiti profile prema skici "A" i pomoću pripadajućeg šablona izbušiti rupe  $\varnothing 4$

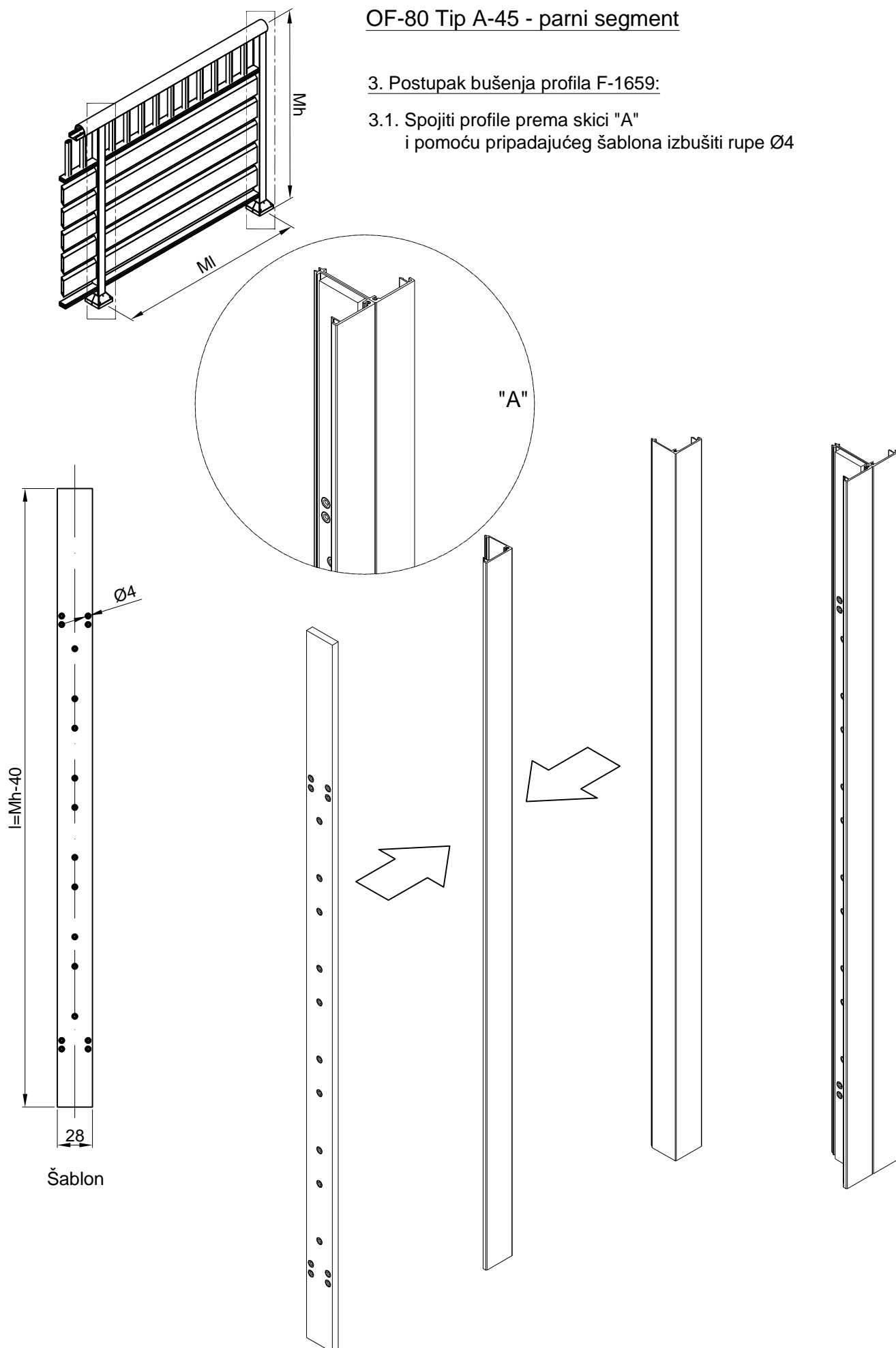

### OF-80 Tip A-45 - neparni segment

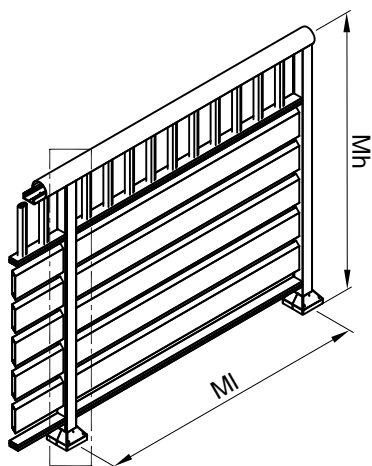

#### 4. Postupak spajanja profila F-1663, F-1659 i F-1660:

4.1. Profile F-1663 i F-1667 pričvrstiti za profil F-1666 vijcima 433.020 (3.9x22 DIN 7981)

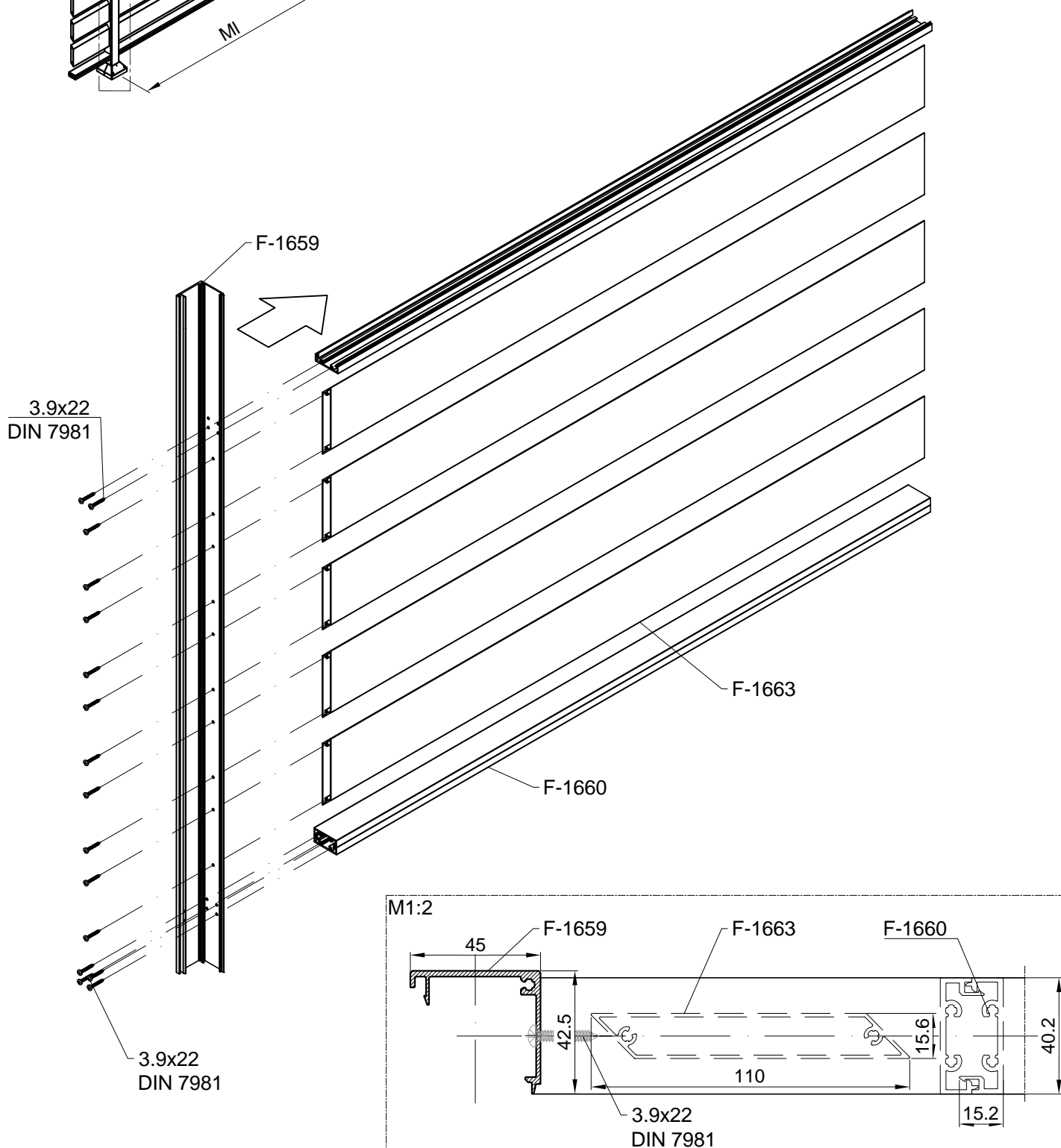

### OF-80 Tip A-45 - parni segment

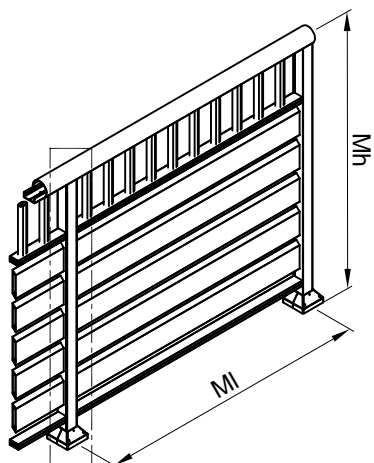

#### 4. Postupak spajanja profila F-1663, F-1659 i F-1660:

4.1. Profile F-1663 i F-1667 pričvrstiti za profil F-1666 vijcima 433.020 (3.9x22 DIN 7981)

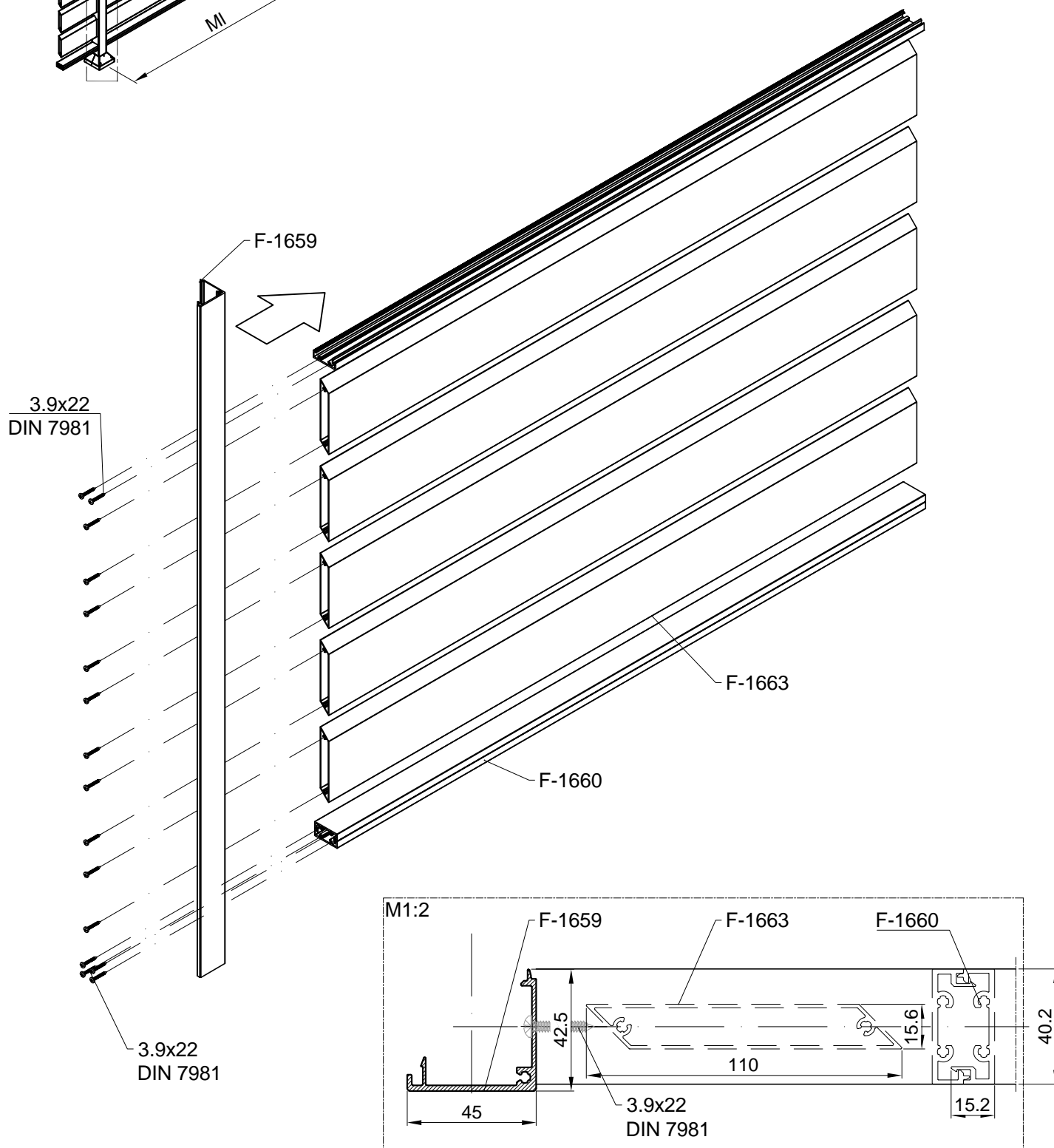

### OF-80 Tip A-45 - neparni segment

#### 4. Postupak spajanja profila F-1663, F-1659 i F-1660:

##### 4.1. Profile F-1663 i F-1667 pričvrstiti za profil F-1666 vijcima 433.020 (3.9x22 DIN 7981)

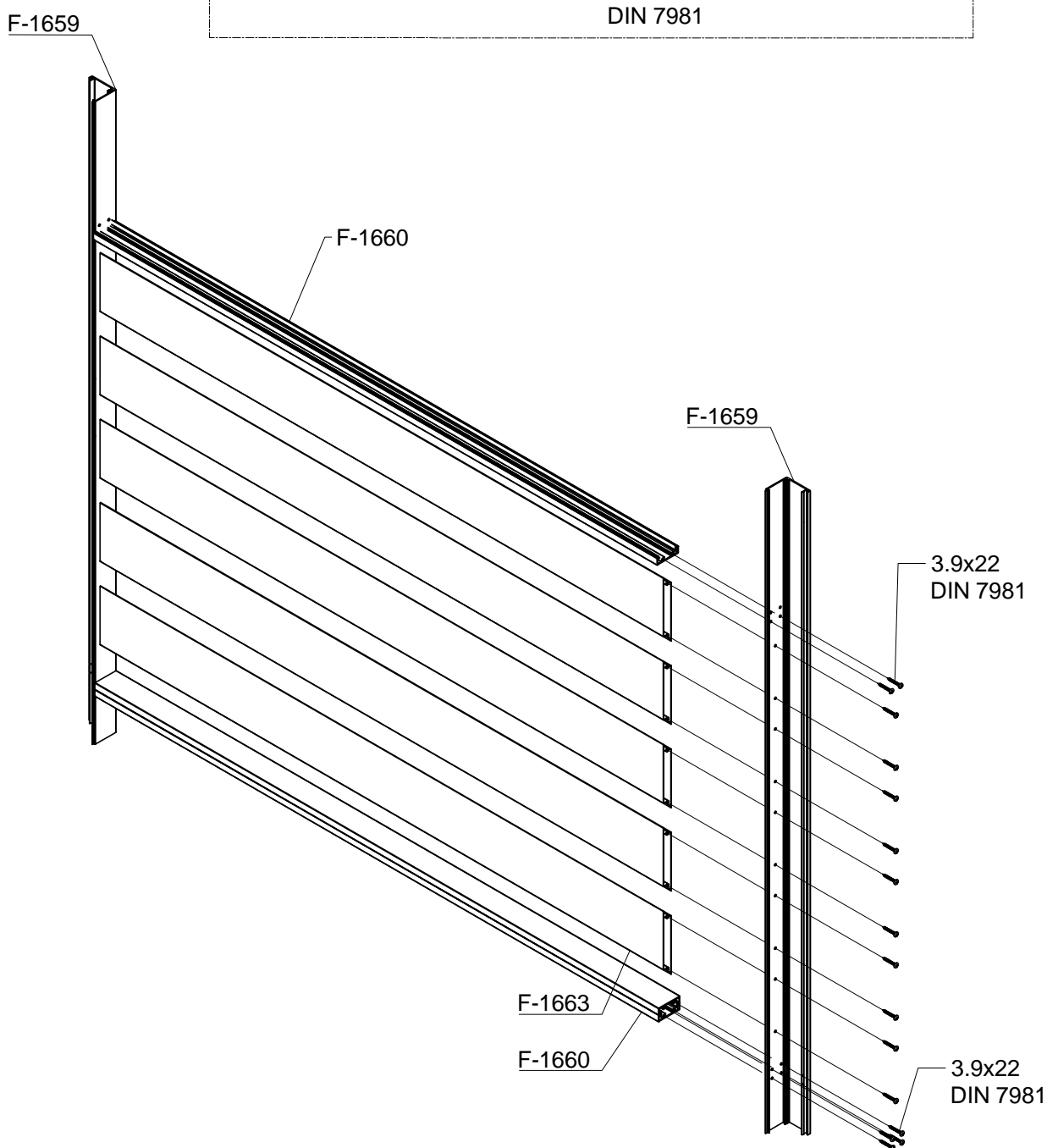
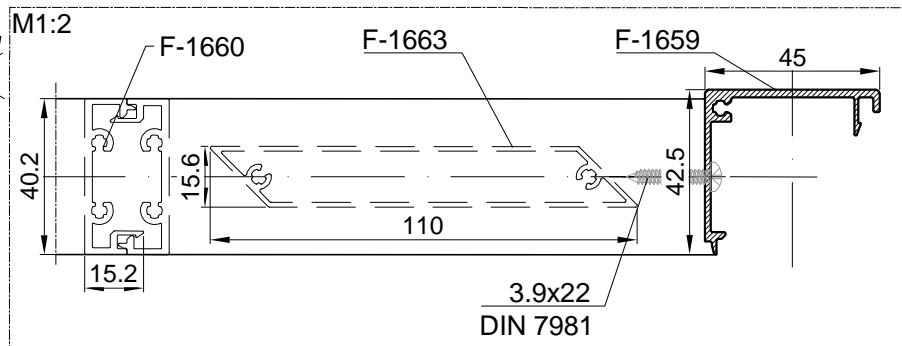
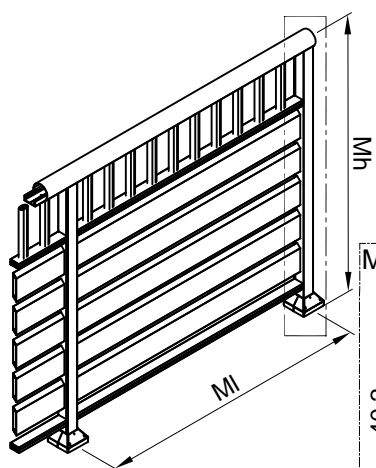

#### OF-80 Tip A-45 - parni segment

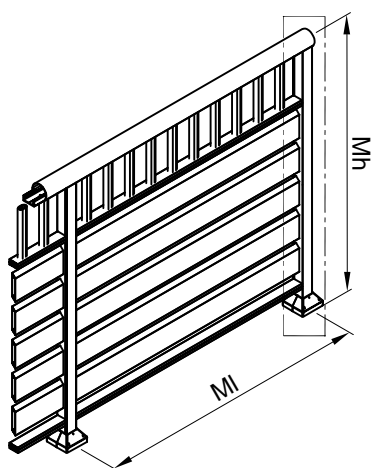

#### 4. Postupak spajanja profila F-1663, F-1659 i F-1660:

4.1. Profile F-1663 i F-1667 pričvrstiti za profil F-1666 vijcima 433.020 (3.9x22 DIN 7981)

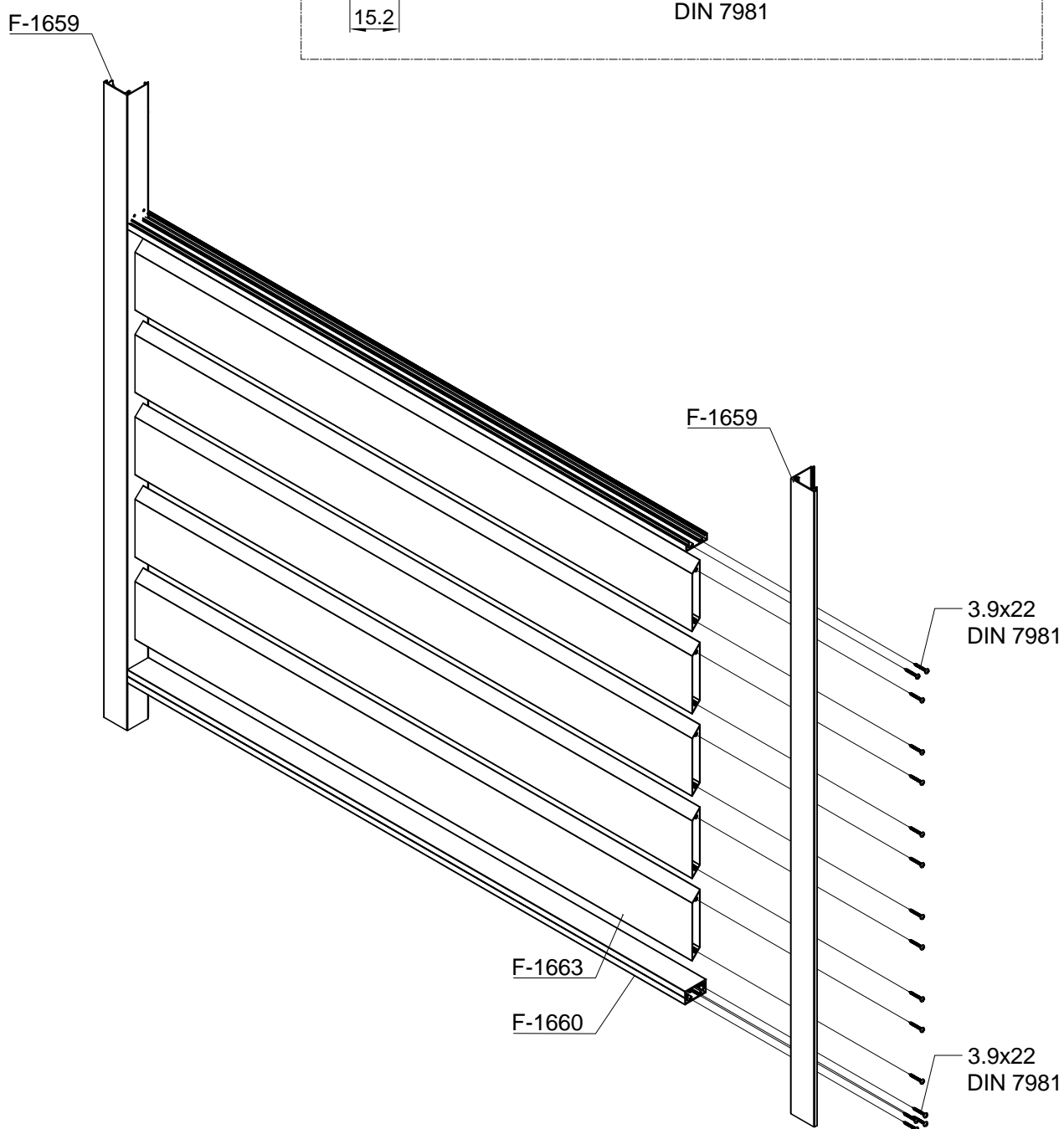
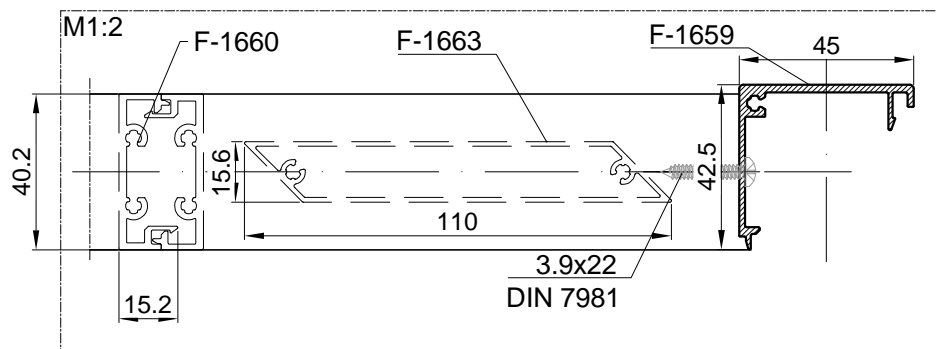

### OF-80 Tip A-45

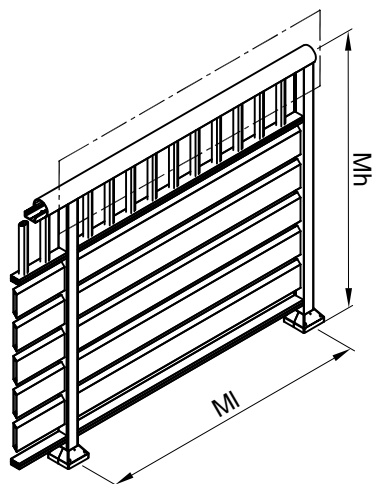

#### 8. Postupak obrade profila F-1660 i F-0620:

- 8.1. Na profilu F-1660 napraviti rupe  $\varnothing 4$
- 8.2. Na profilu F-0620 napraviti rupe  $\varnothing 4$

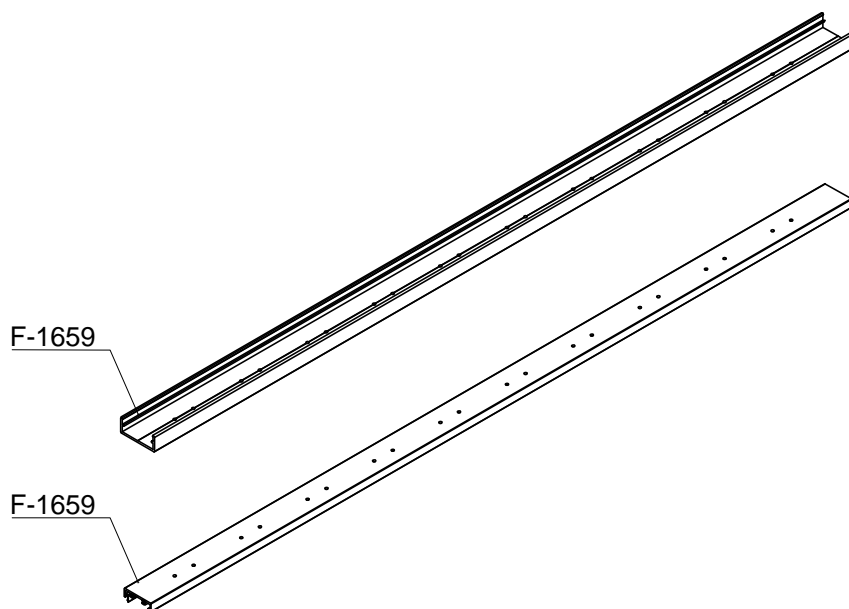
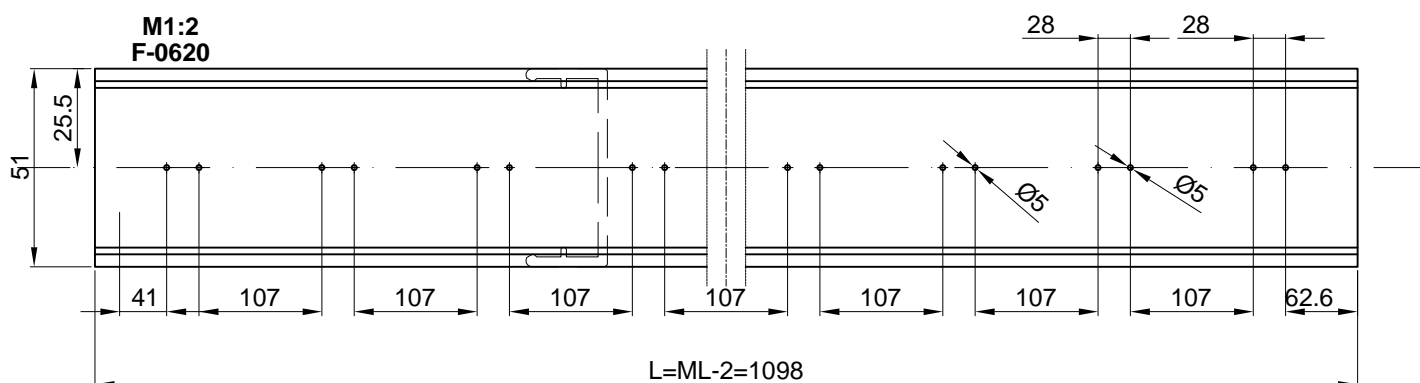
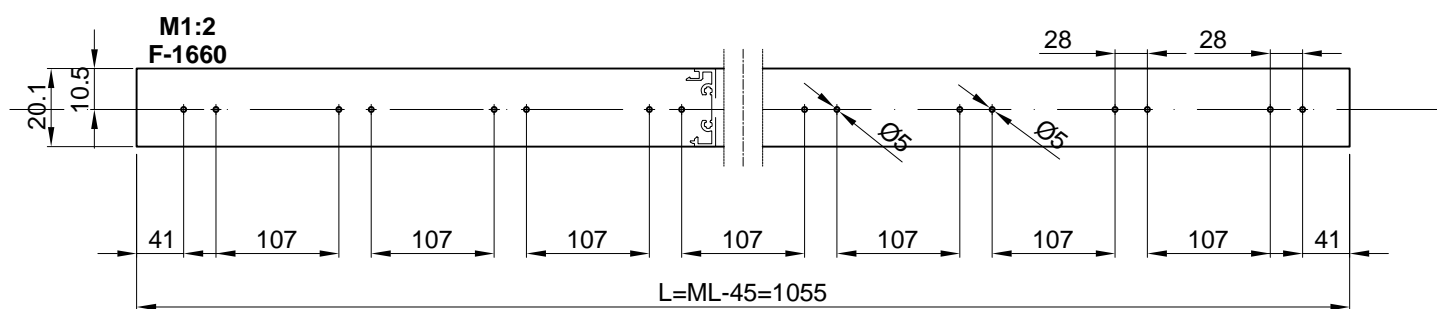

### OF-80 Tip A-45

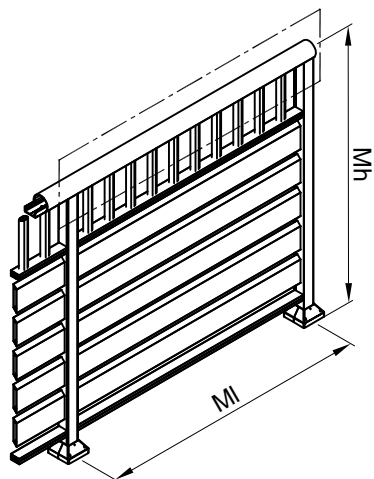

#### 9. Postupak spajanja profila F-1660, F-0620 i OG-111:

- 9.1. Profile OG-111 ispilati na visinu 213 mm.
- 9.2. Na profil F-1660 pričvrstiti profile OG-111 vijcima 433.031 (4.2x22 DIN 7981)
- 9.3. S gornje strane pričvrstiti profil F-0620 vijcima 433.031 (4.2x22 DIN 7981)

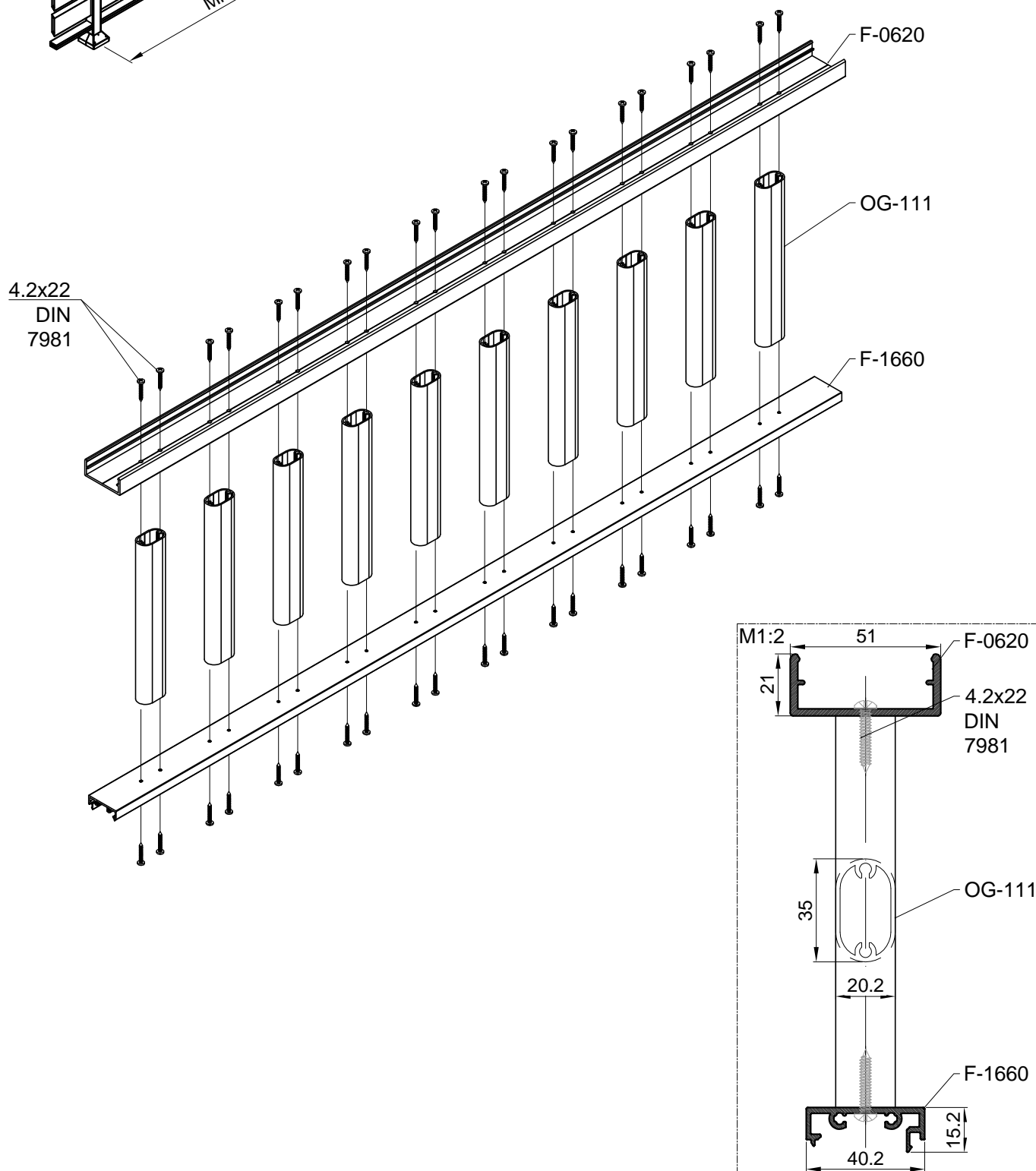

### OF-80 Tip A-45

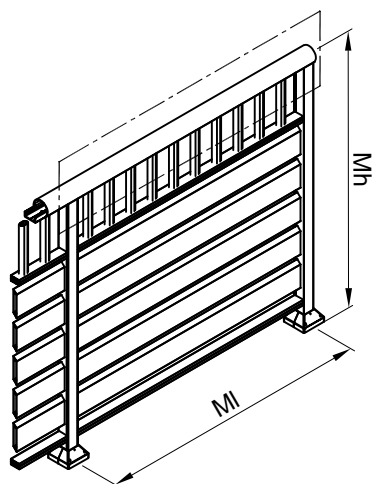

10. Postupak spajanja gornjeg dijela segmenta s donjim segmentom:

10.1. Gornji dio segmenta postaviti između vertikalnih profila F-1666, zatim ih pričvrstiti vijcima 433.108 (3.9x22 DIN 7981)

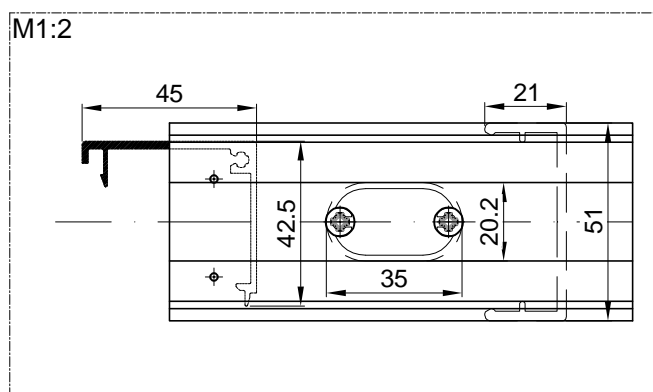
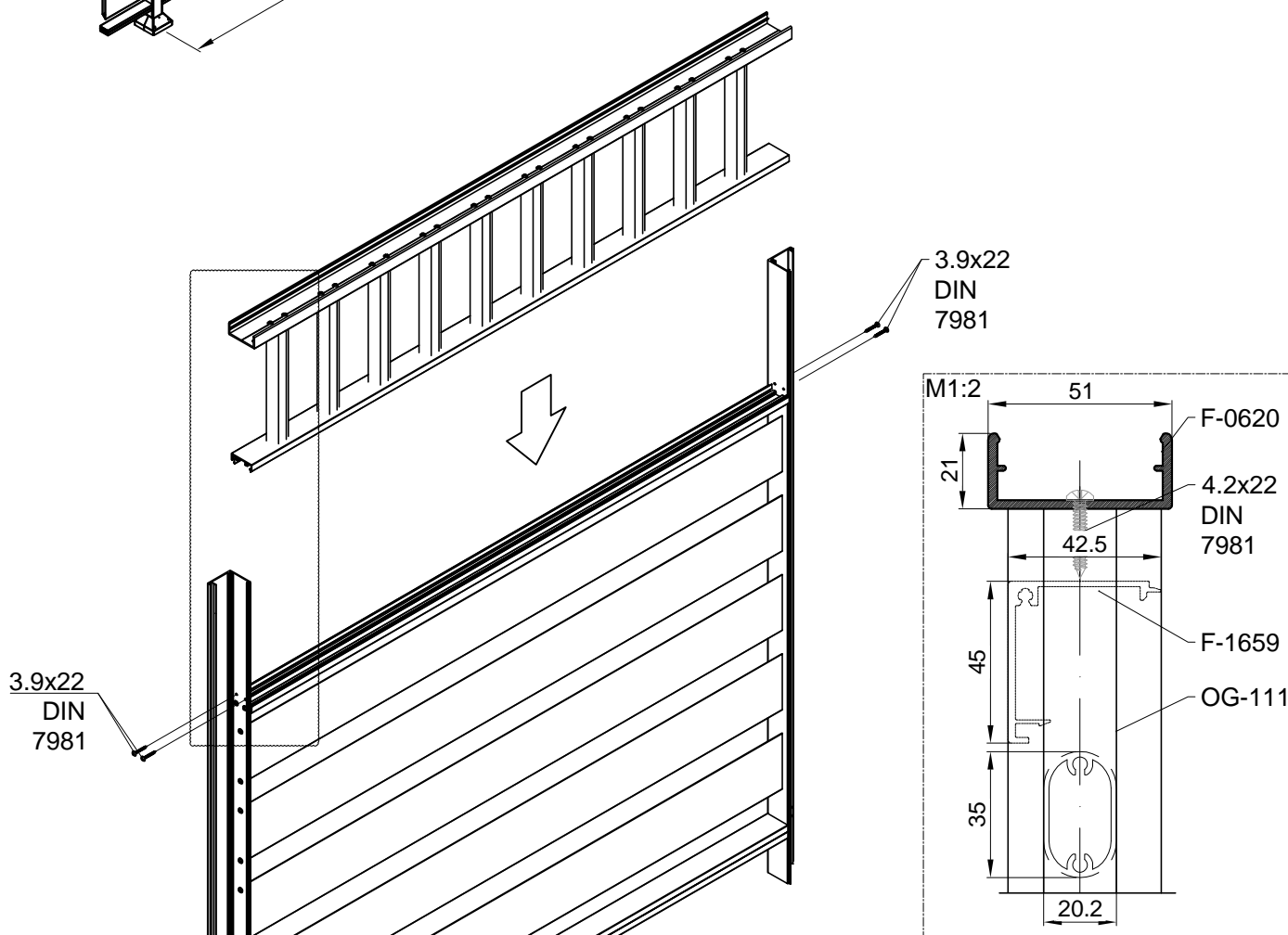

**NAPOMENA:** Parni i neparni segment se radi zrcalno u paru.

### OF-80 Tip A-45

M1:5

#### 11. Segment OF-80 tipa A:

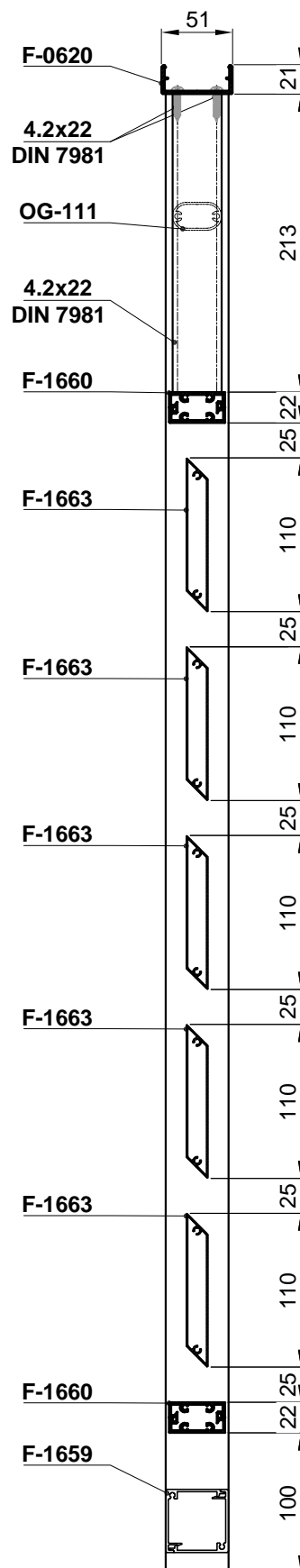
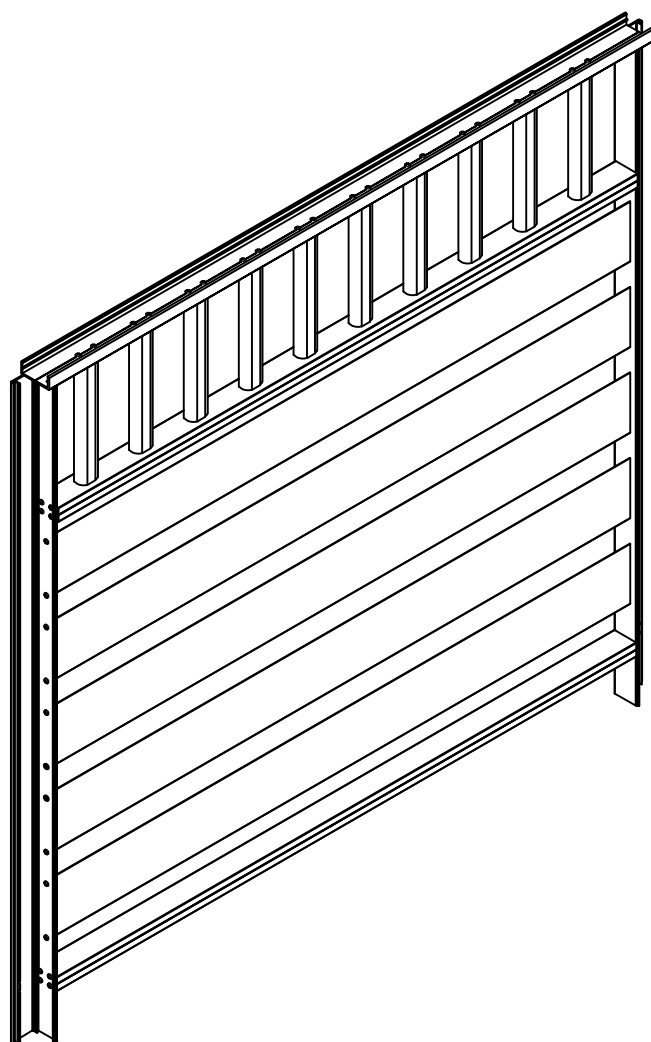
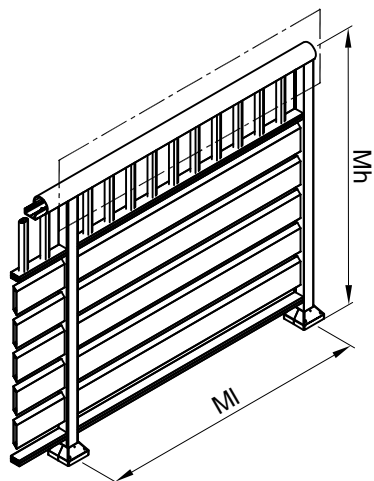

NAPOMENA: Parni i neparni segment se radi zrcalno u paru.

### OF-80 Tip A-86

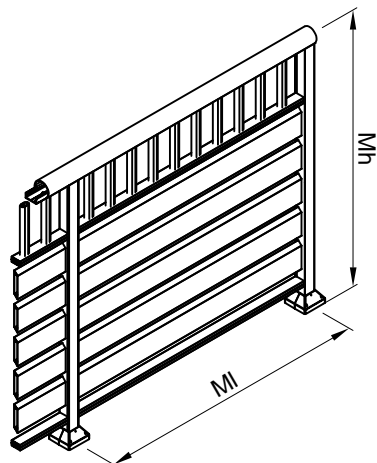

#### 14. Montaža segmenata OF-80 tipa A:

- 14.1. Postavljamo neparni segment kapije OF-80 Tip A-45, koje pričvršćujemo vijcima 433.108 (3.9x22 DIN 7981)
- 14.2. Postavljamo parni segment kapije OF-80 Tip A-86, koje pričvršćujemo vijcima 433.108 (3.9x22 DIN 7981)
- 14.3. Na dnu spojenih parnih i neparnih segmenata kapije OF-80 Tip A-45, postavljamo rozetu 392.001 koji pričvršćujemo vijcima M5x50

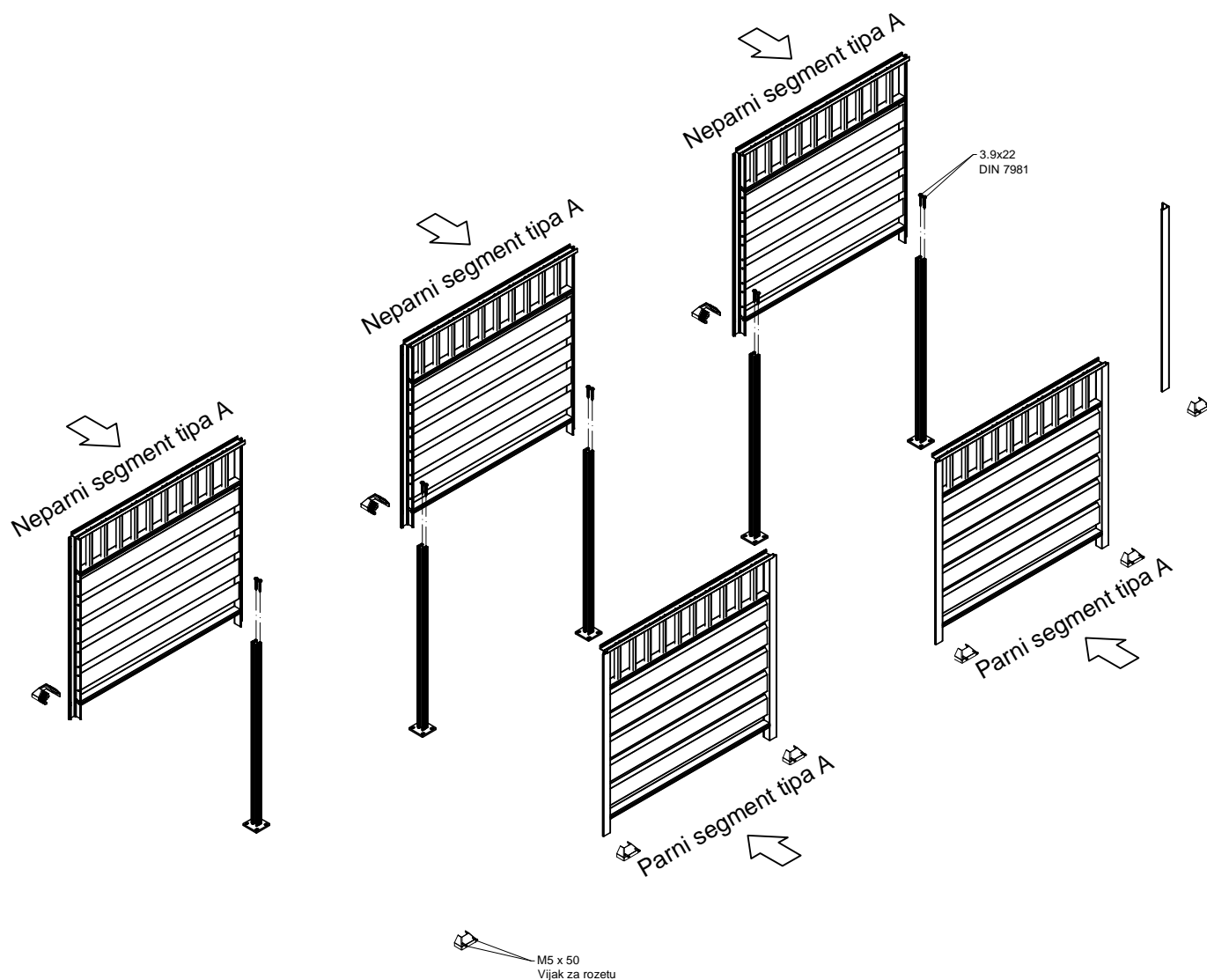

### OF-80 Tip A-86

#### 15. Montaža segmenata OF-80 tipa A:

15.1. Na sastavljene segmente kapije postavljamo rukohvat F-0620, na krajevima rukohvata postavljamo PVC čepove 391.204

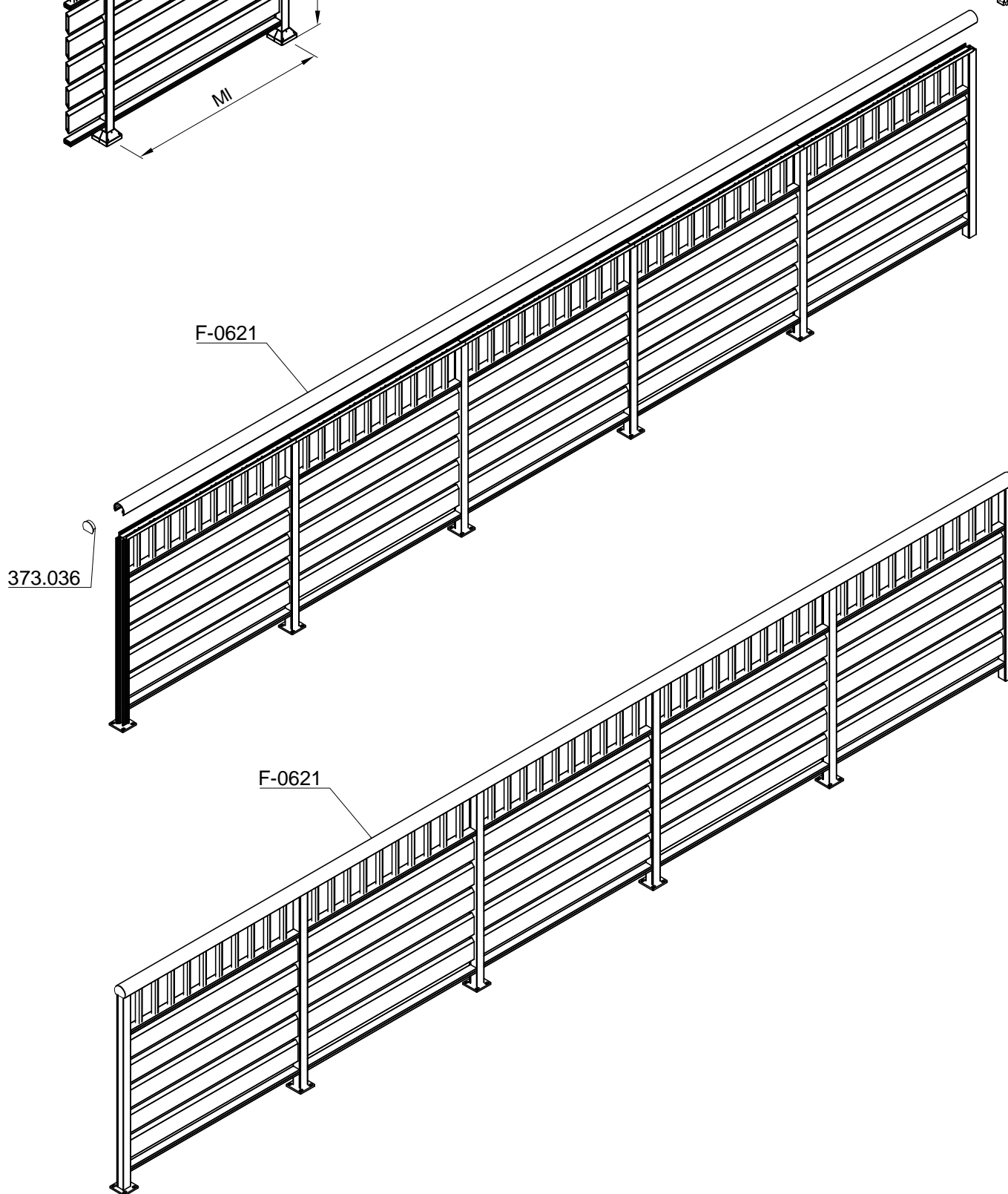
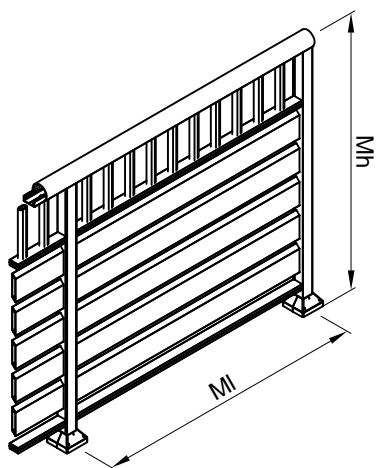



# OBRADA I MONTAŽA KAPIJE TIP KC-86

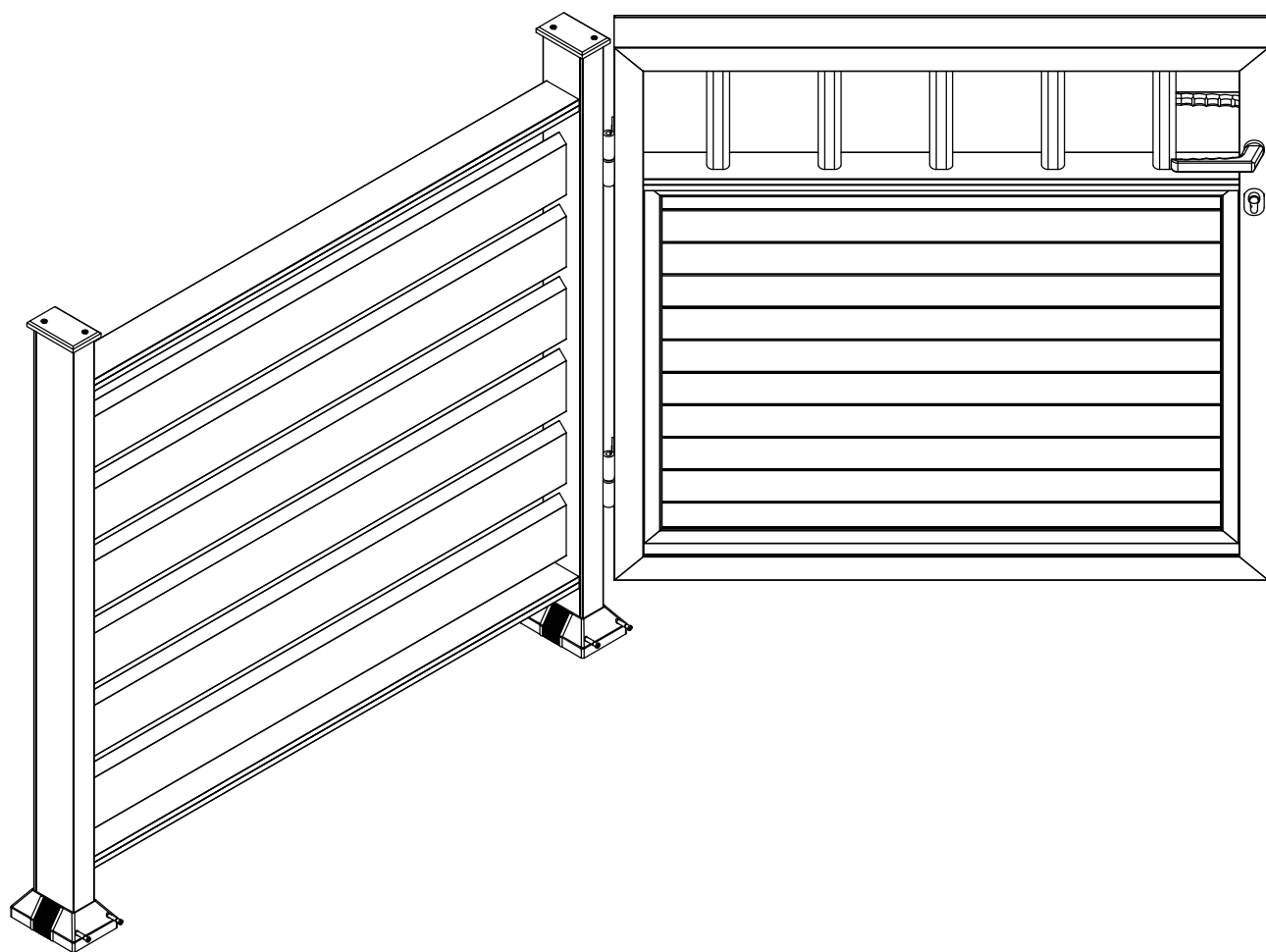
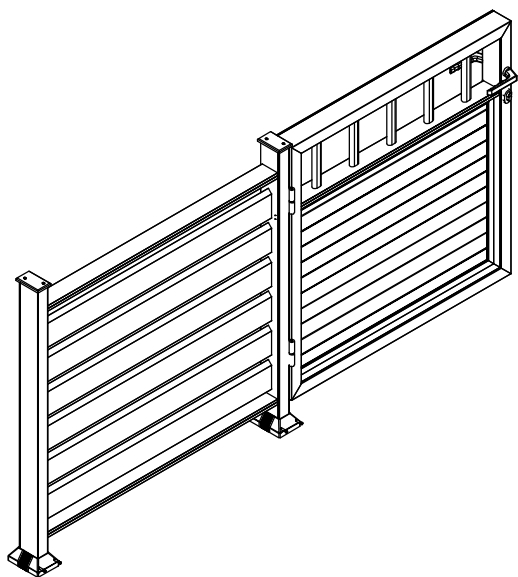

OF-80 Tip KC-86

#### OF-80 Tip KC-86

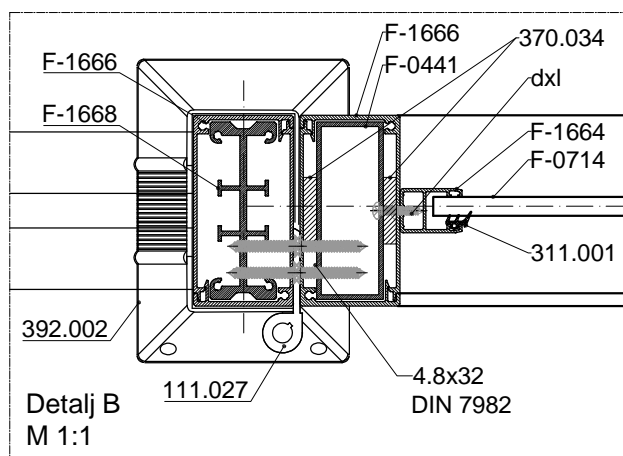
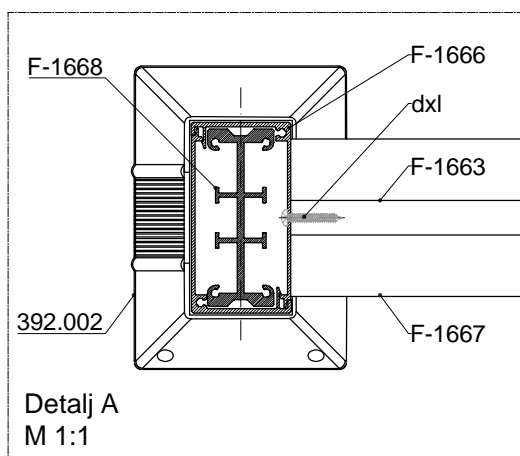
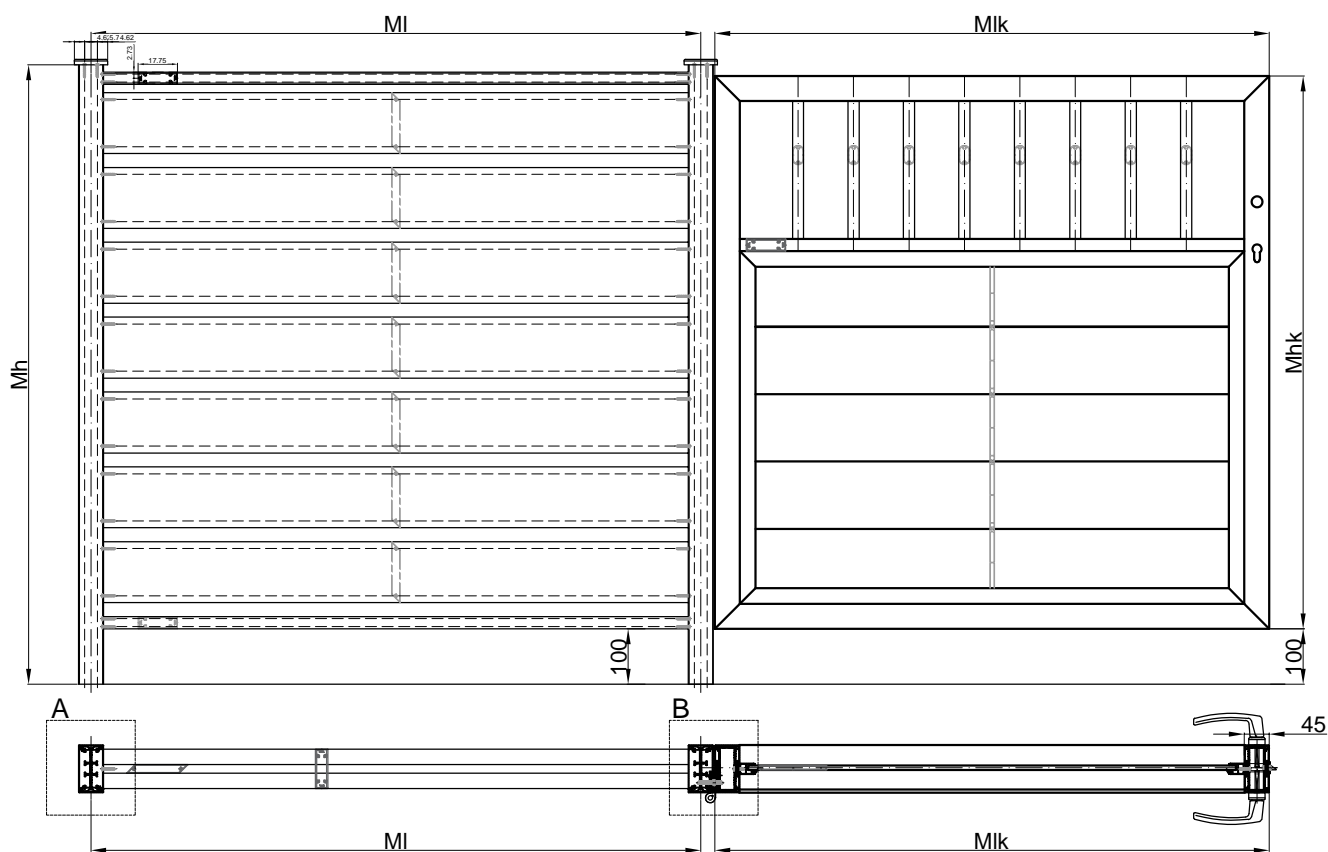
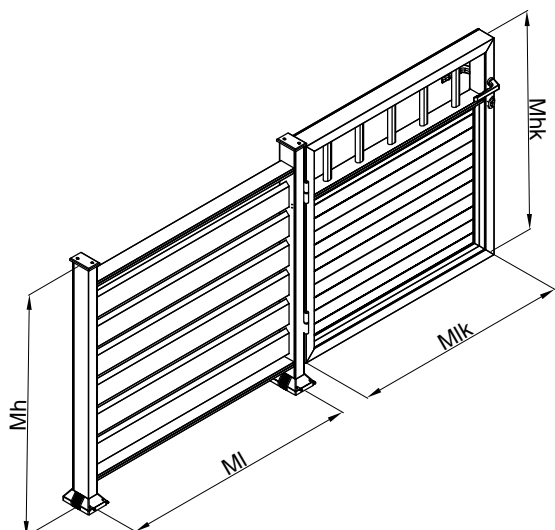

OF-80 Tip KC-86

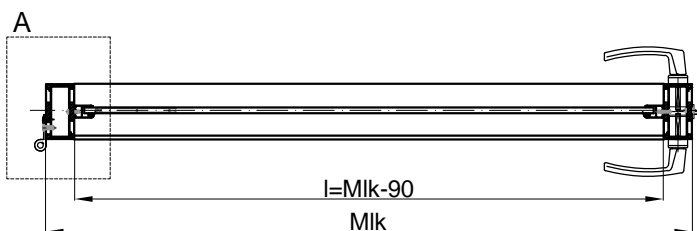
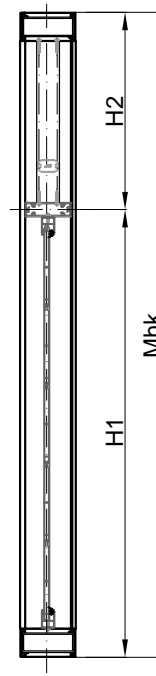
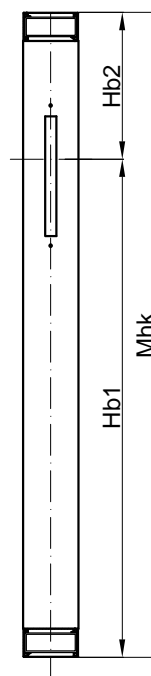
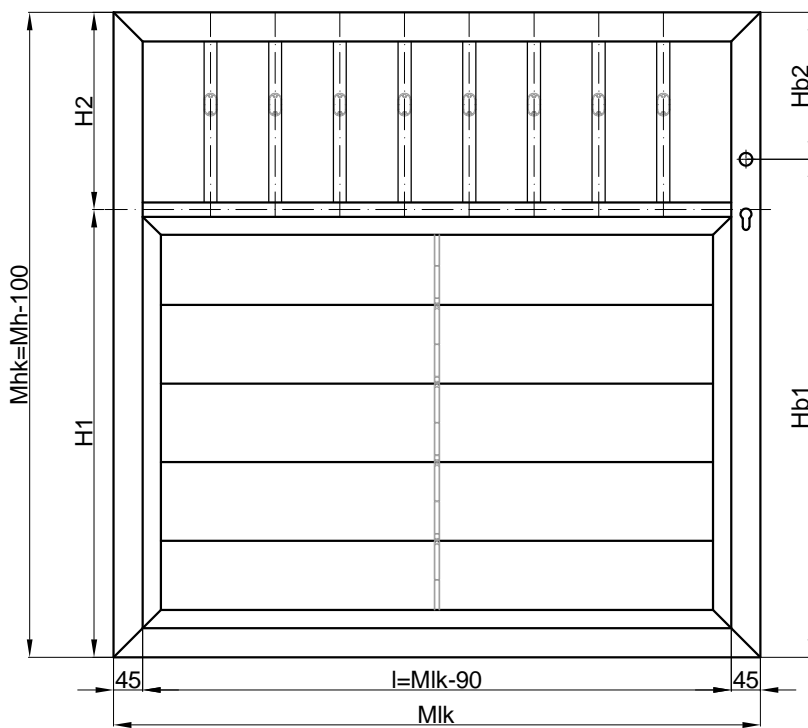
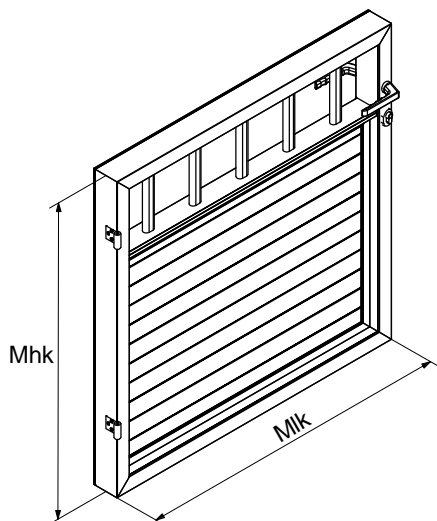

Detalj A  
M 1:1

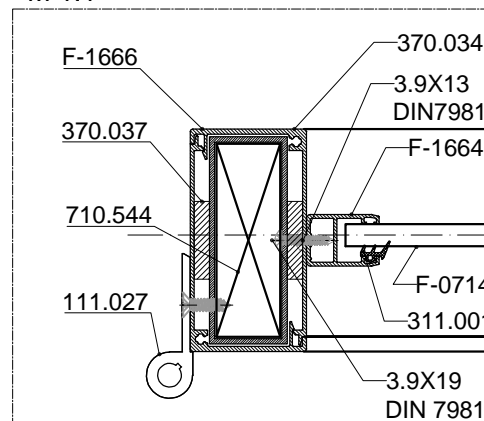

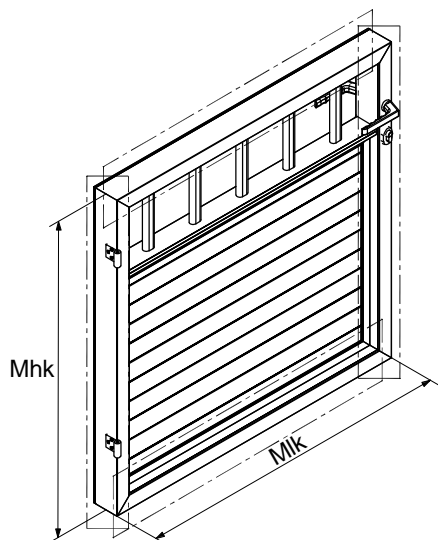

### OF-80 Tip KC-86

npr.: za  $Mlk=1000$  mm i  $Mhk=MH-100=992$  mm

$H1=Mhk-H2=692$  mm

$H2=Mhk-H1=300$  mm

$Hb1=Mhk-Hb2=770$  mm

$Hb2=Mhk-Hb1=222$  mm

#### 1. Postupak pilanja profila F-1666:

- 1.1. Ispilati profile F-1666 pod kutem  $45^\circ$  na mjere  $l=Mhk$  mm prema crtežu
- 1.2. Ispilati profile F-1666 pod kutem  $45^\circ$  na mjere  $l=MLk$  mm prema crtežu

#### Unutarnji profili

F-1666 kom:2 x br. segmenata

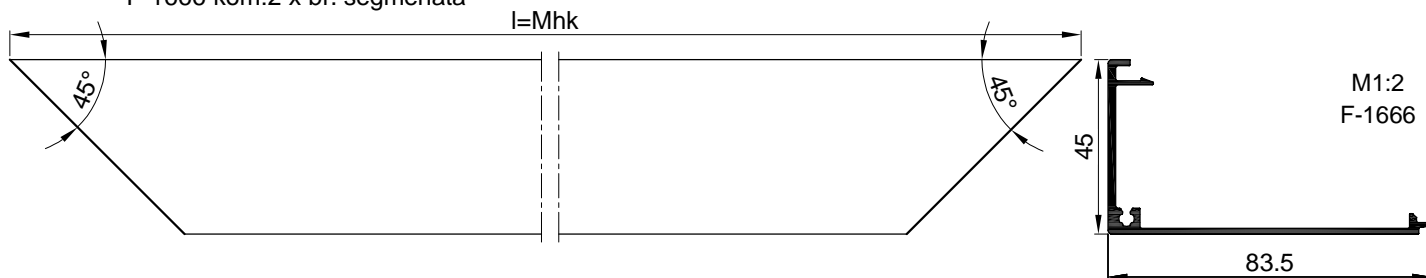

F-1666 kom:2 x br. segmenata

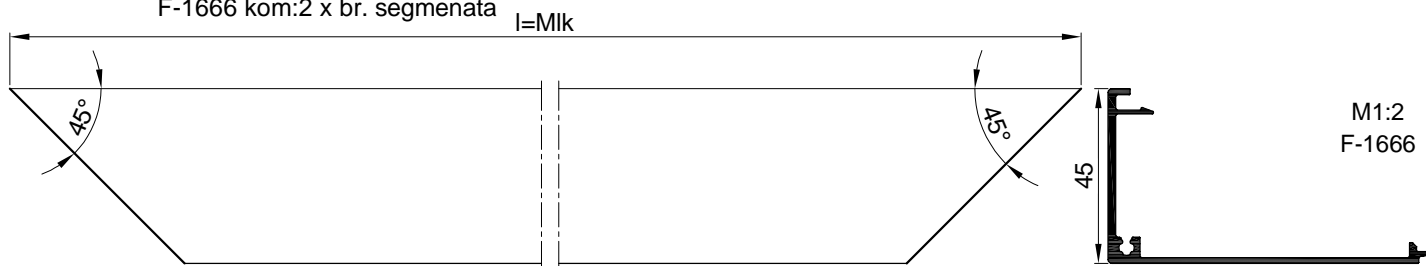

#### Vanjski profili

F-1666 kom:2 x br. segmenata

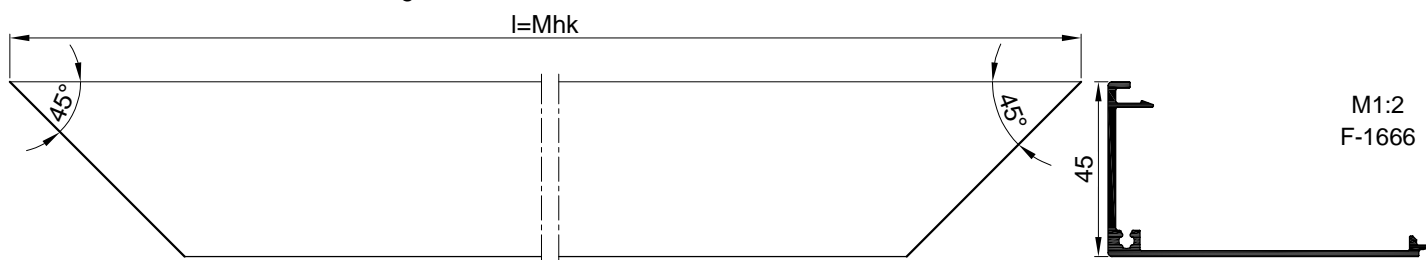

F-1666 kom:2 x br. segmenata

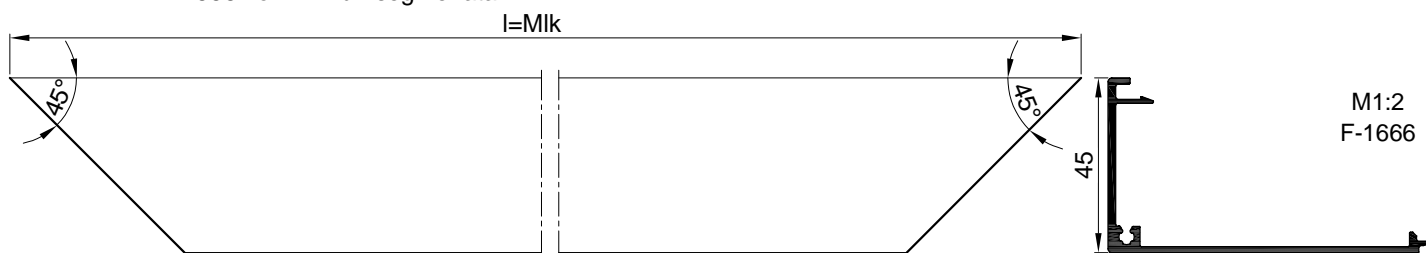

### OF-80 Tip KC-86

#### 2. Postupak obrade profila F-1664:

- 2.1. Pisanje profila F-1666 na mjere  $l=Mh-40$
- 2.2. Pisanje profila F-1664 pod kutem  $45^\circ$  na mjere  $l=Mlk-90$
- 2.3. Pisanje profila F-1664 pod kutem  $45^\circ$  na mjere  $l=H1-56$
- 2.4. Pisanje profila F-0714 na mjere  $l=Mlk-120$

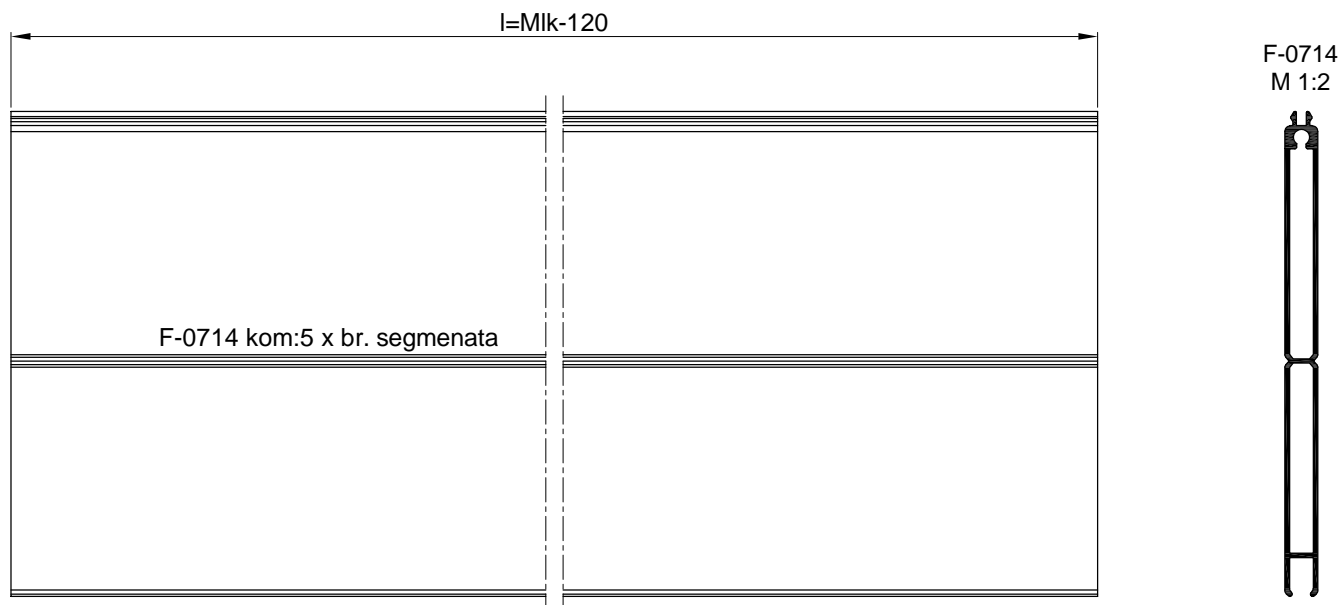
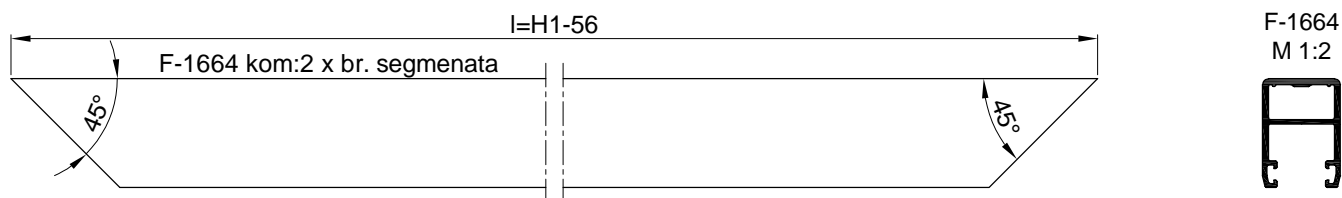
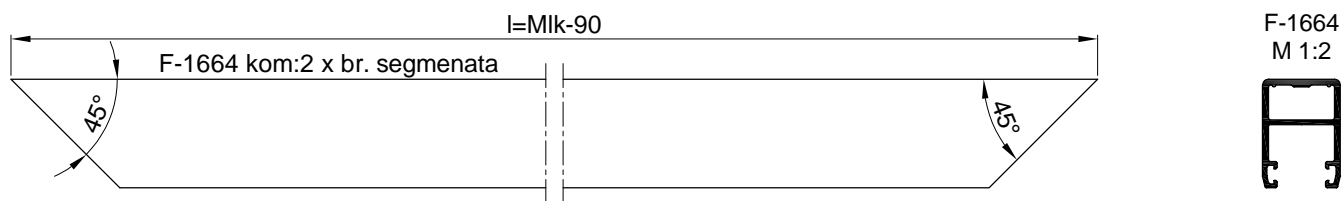
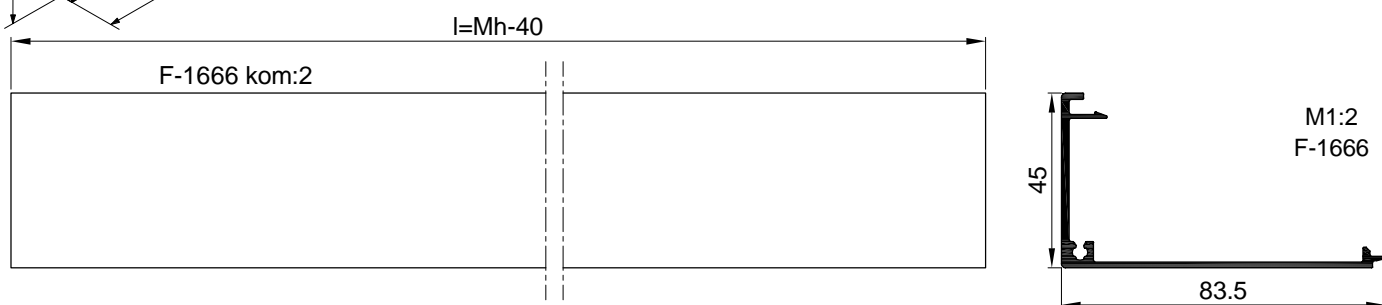
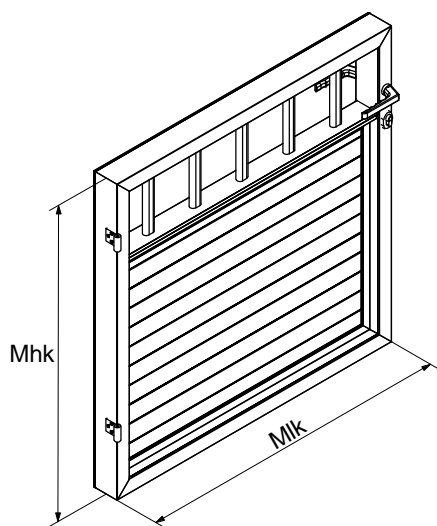

### OF-80 Tip KC-86

#### 3. Postupak obrade profila F-0714:

- 3.1. Pisanje profila F-1667 na mjere  $l=Mik-90$
- 3.2. Pisanje profila F-0441 na mjere  $l=Mik-15$
- 3.3. Pisanje profila F-0441 na mjere  $l=Mhk-15$
- 3.4. Pisanje profila OG-111 na mjere  $l=H2-56$

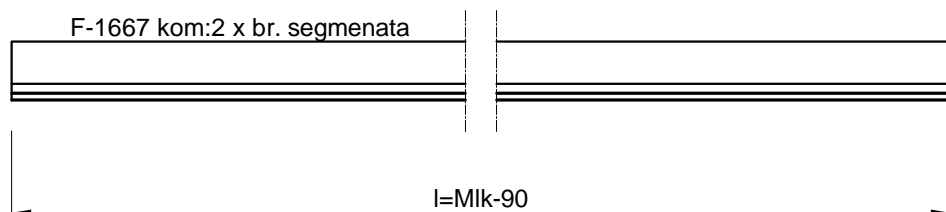
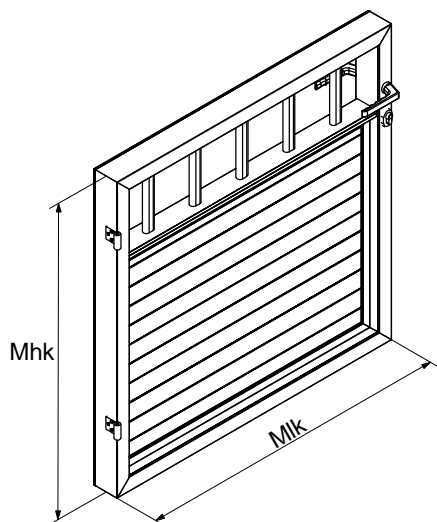

F-1667  
M 1:2

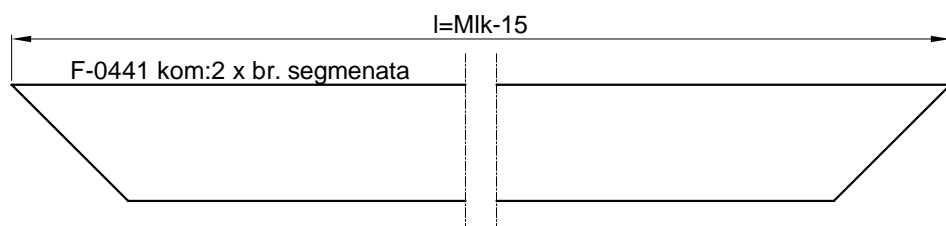

F-0441  
M 1:2

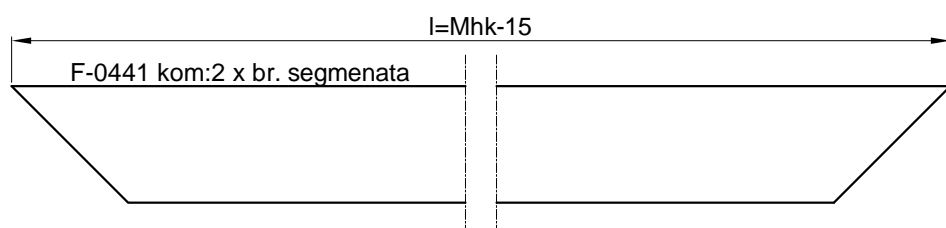

F-0441  
M 1:2

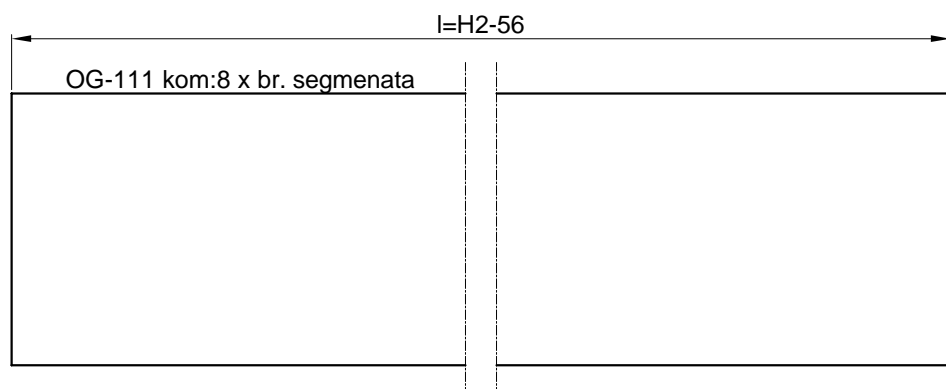

OG-111  
M 1:1

### OF-80 Tip KC-86

#### 4. Postupak obrade profila F-1664:

##### 4.1. Obraditi profile F-1664 za kutne spojnice 725.213 prema crtežu

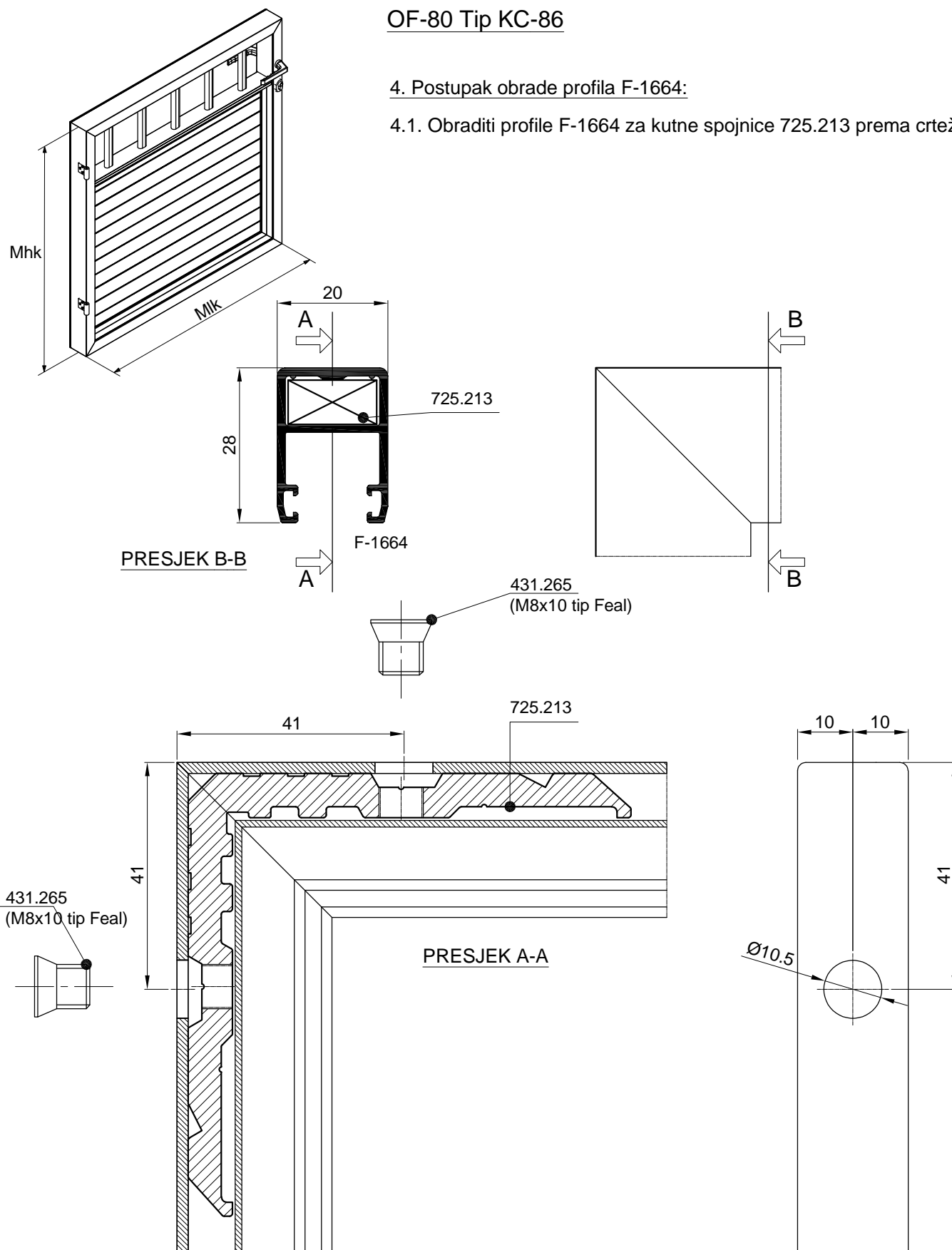

725.213 (F-1628)

NAPOMENA: SPAJANJE PROFILA KUTNIM  
SPOJNICAMA (vijčana veza)

#### OF-80 Tip KC-86

##### 5. Postupak obrade profila F-0441:

5.1. Obraditi profile F-0441 za kutne spojnice 710.544 prema crtežu

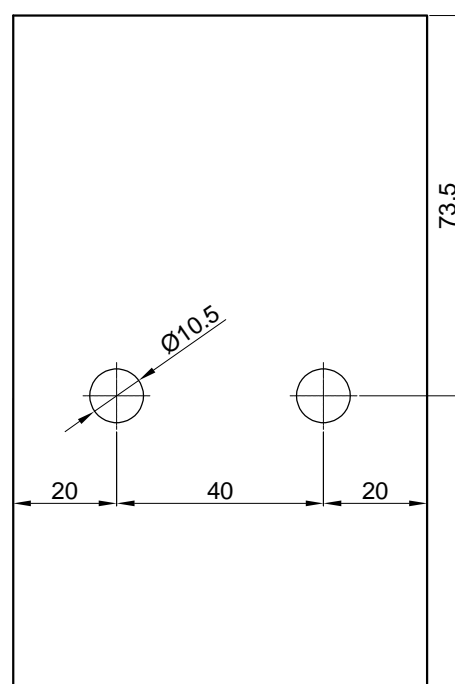
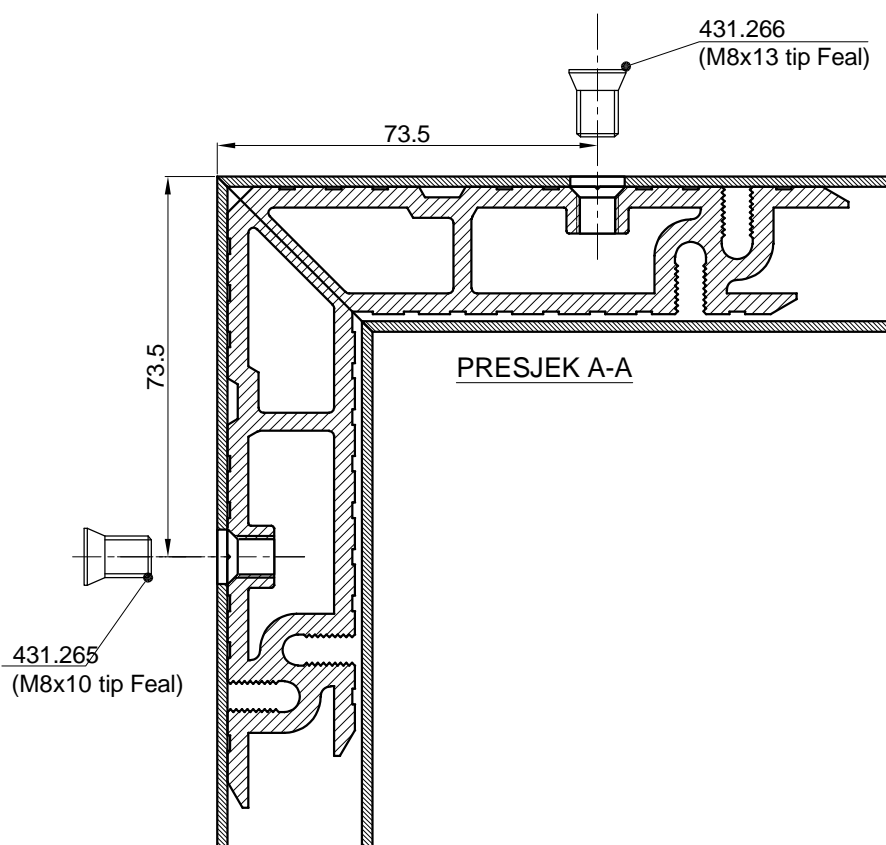
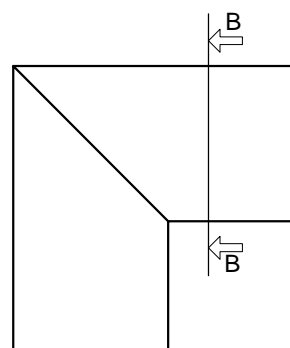
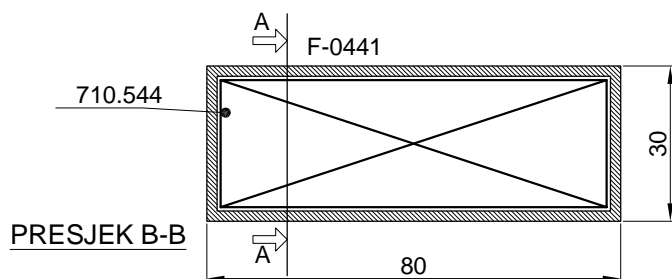
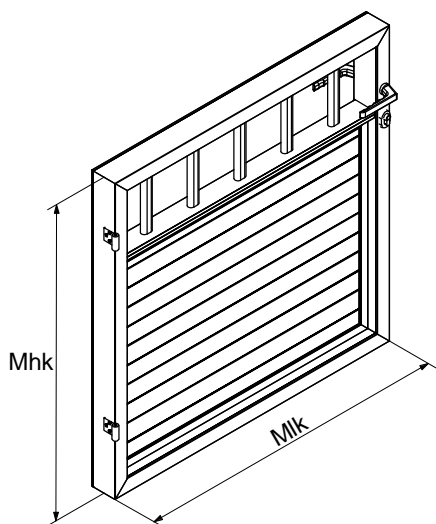

NAPOMENA: SPAJANJE PROFILA KUTNIM SPOJNICAMA (vijčana veza)

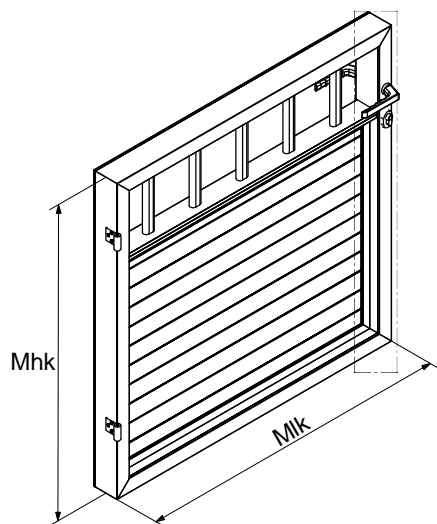

### OF-80 Tip KC-86

#### 6. Postupak obrade profila F-1666 i F-0441:

- 6.1. Izbušiti rupe  $\varnothing 5$  i  $\varnothing 4$  na vanjskom profilu F-1666 za prihvat baglame prema crtežu
- 6.2. Izbušiti rupe na moždaniku F-0441 za prihvat baglame prema shemi
- 6.3. Izbušiti rupe  $\varnothing 12$  i  $\varnothing 3.2$  na vertikalnim moždanicama F-0441 prema shemi
- 6.4. Izbušiti rupe  $\varnothing 12$  i  $\varnothing 3.2$  na horizontalnom moždaniku F-0441 prema shemi

#### NAPOMENA:

Može se koristiti baglama kao šablon na plaštu i moždaniku

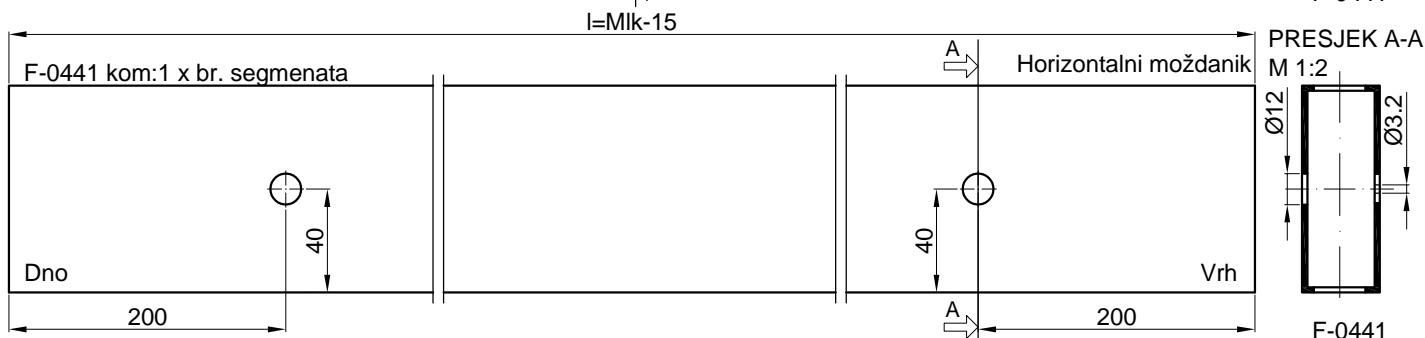
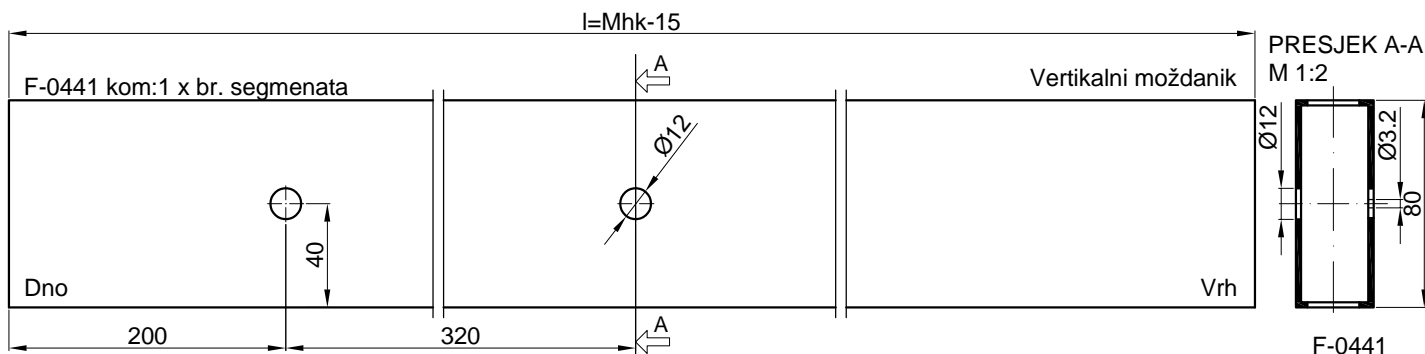
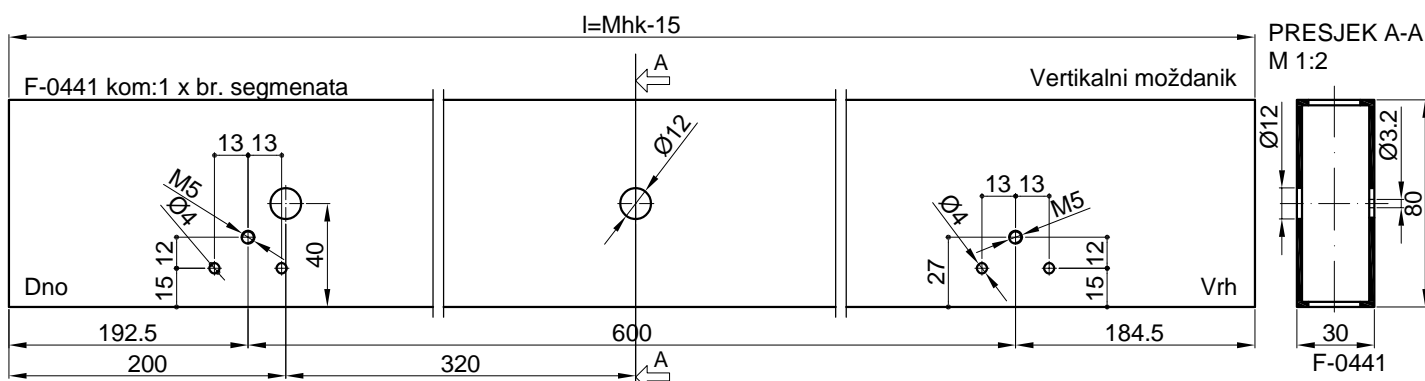
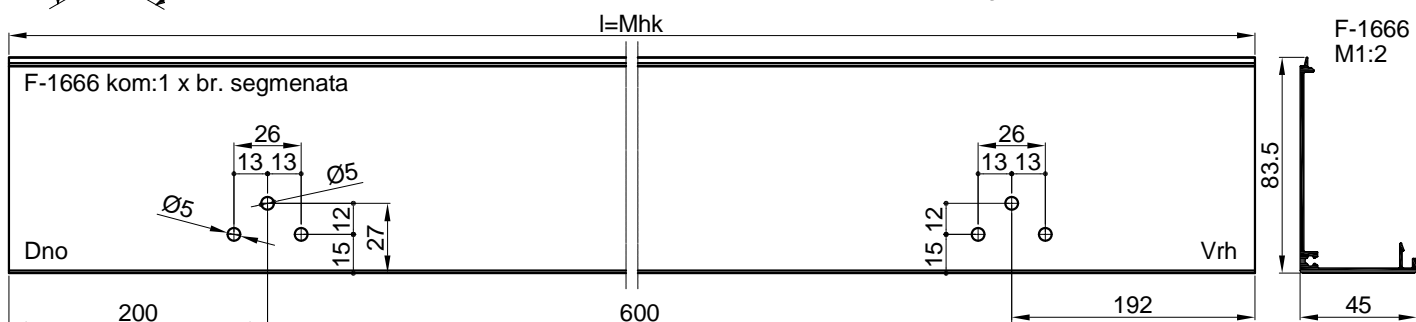



### OF-80 Tip KC-86

#### 8. Postupak sastavljanja profila F-1664:

- 8.1. Obraditi unutarnje profile F-1666 za prihvat ručke prema crtežu
- 8.2. Izbušiti rupe  $\varnothing 4$  na unutarnje vertikalne profile F-1666 prema crtežu

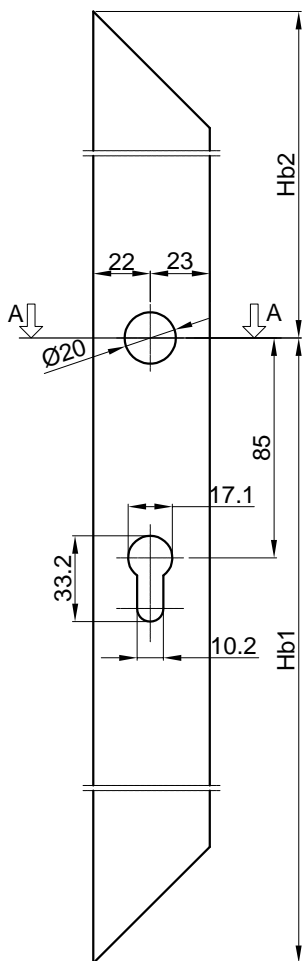
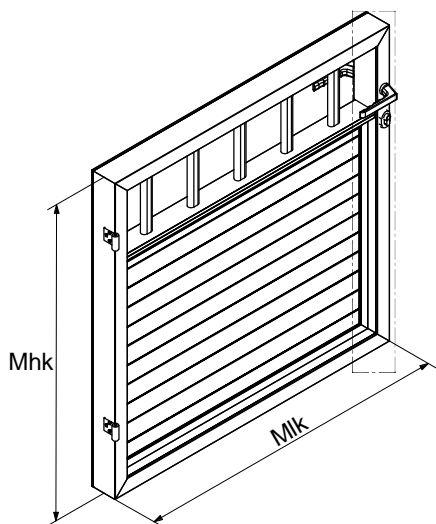

PRESJEK A-A  
M 1:2

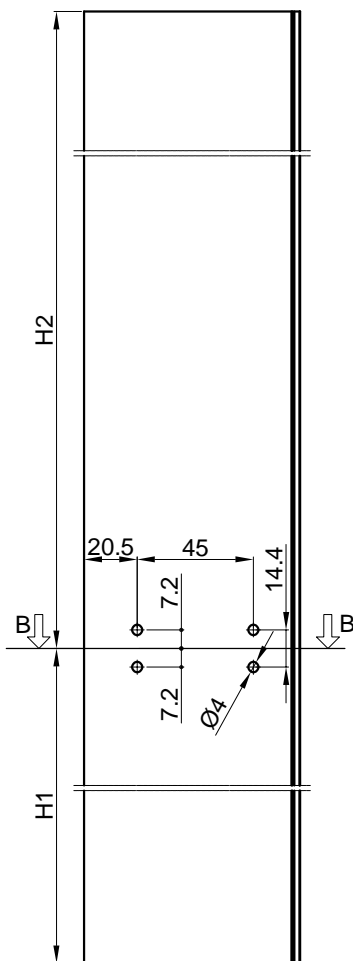
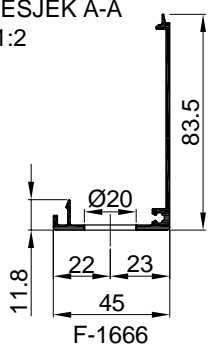

PRESJEK B-B  
M 1:2

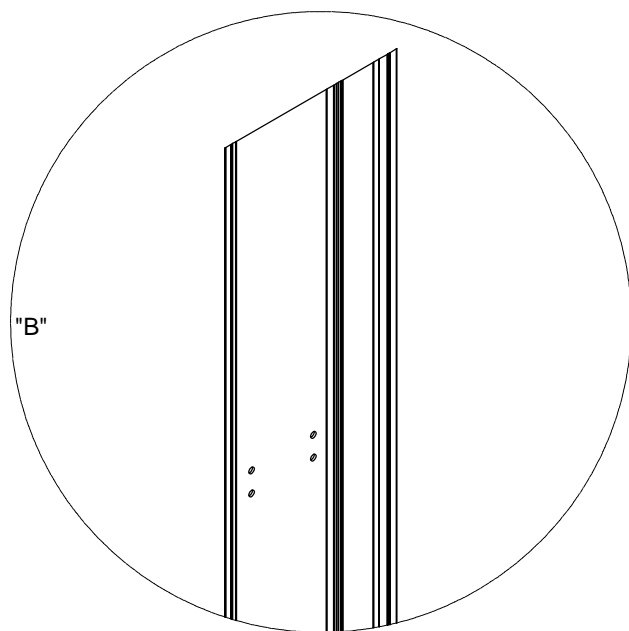
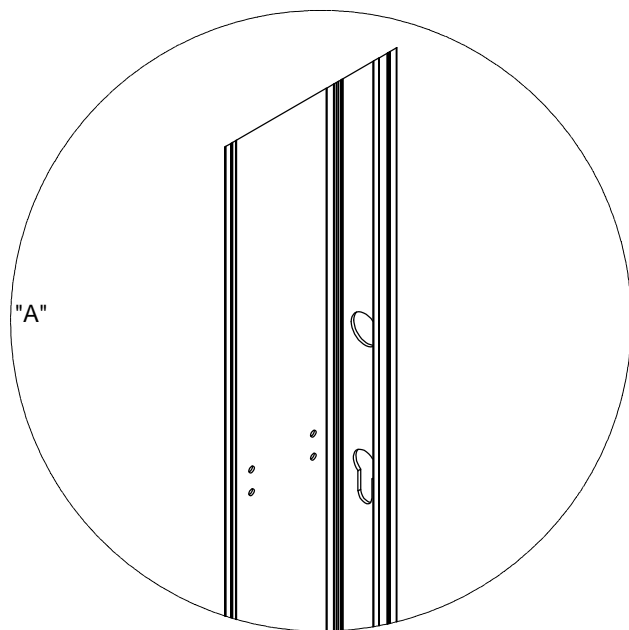
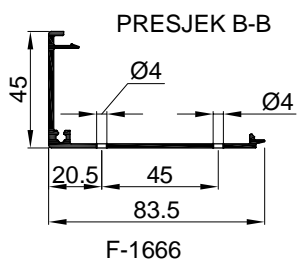

#### OF-80 Tip KC-86

#### 9. Postupak obrade profila F-0441:

#### 9.1. Obraditi vertikalni moždanik profil F-0441 za prihvat brave i ručke

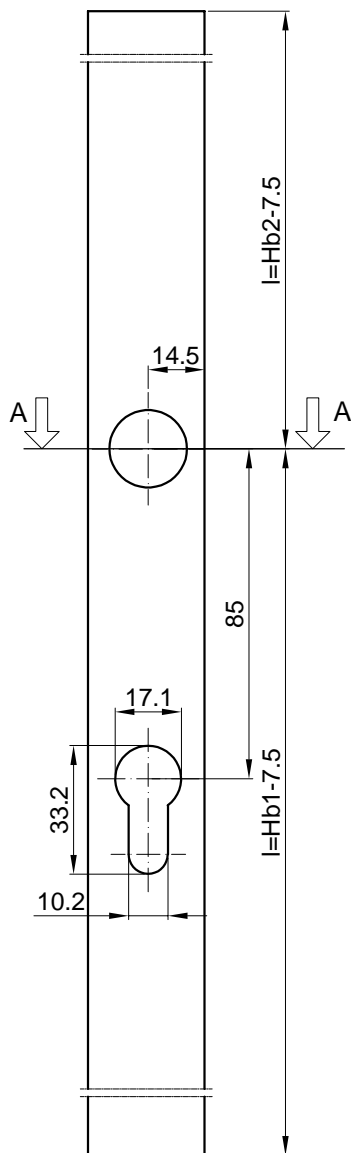
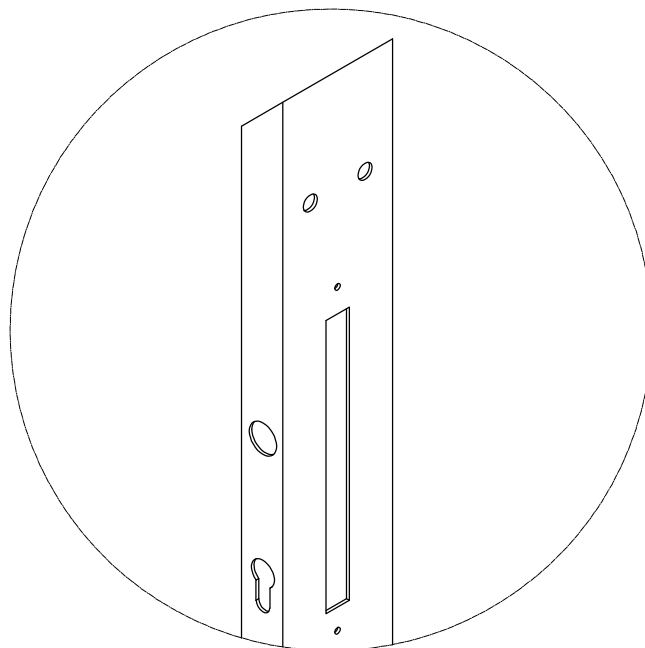
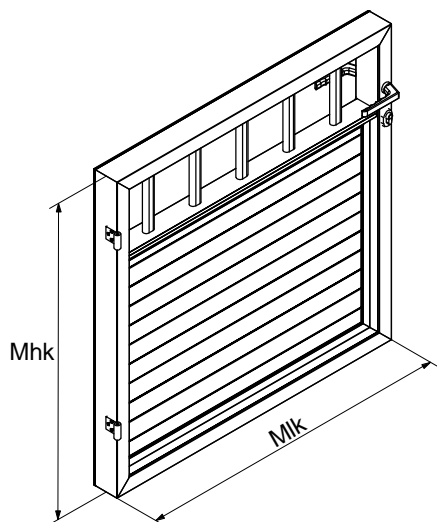

M1:2

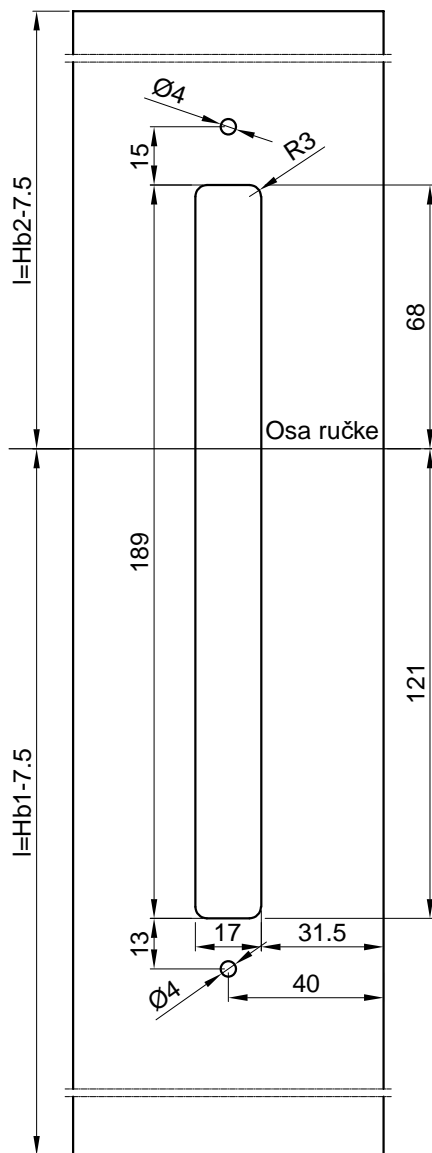

M1:2

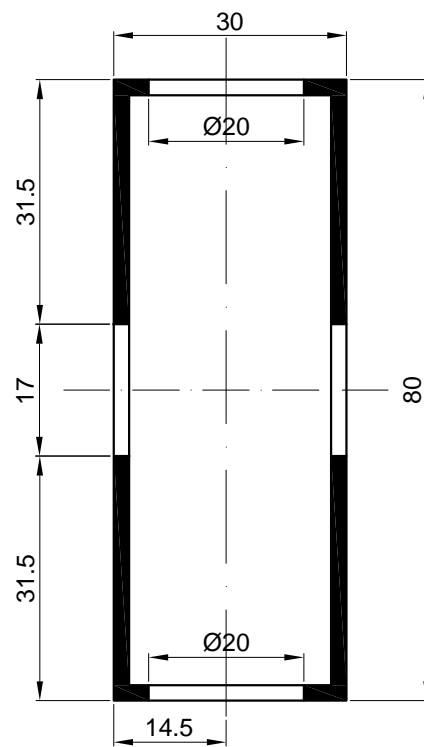

Obrada rama F-0441

Presjek A-A

M1:1

### OF-80 Tip KC-86

#### 10. Postupak obrade profila F-1666:

##### 10.1. Obraditi profil F-1666 za prihvatnik brave prema crtežu

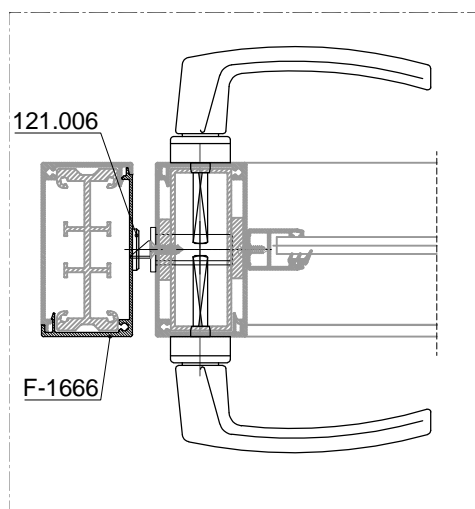
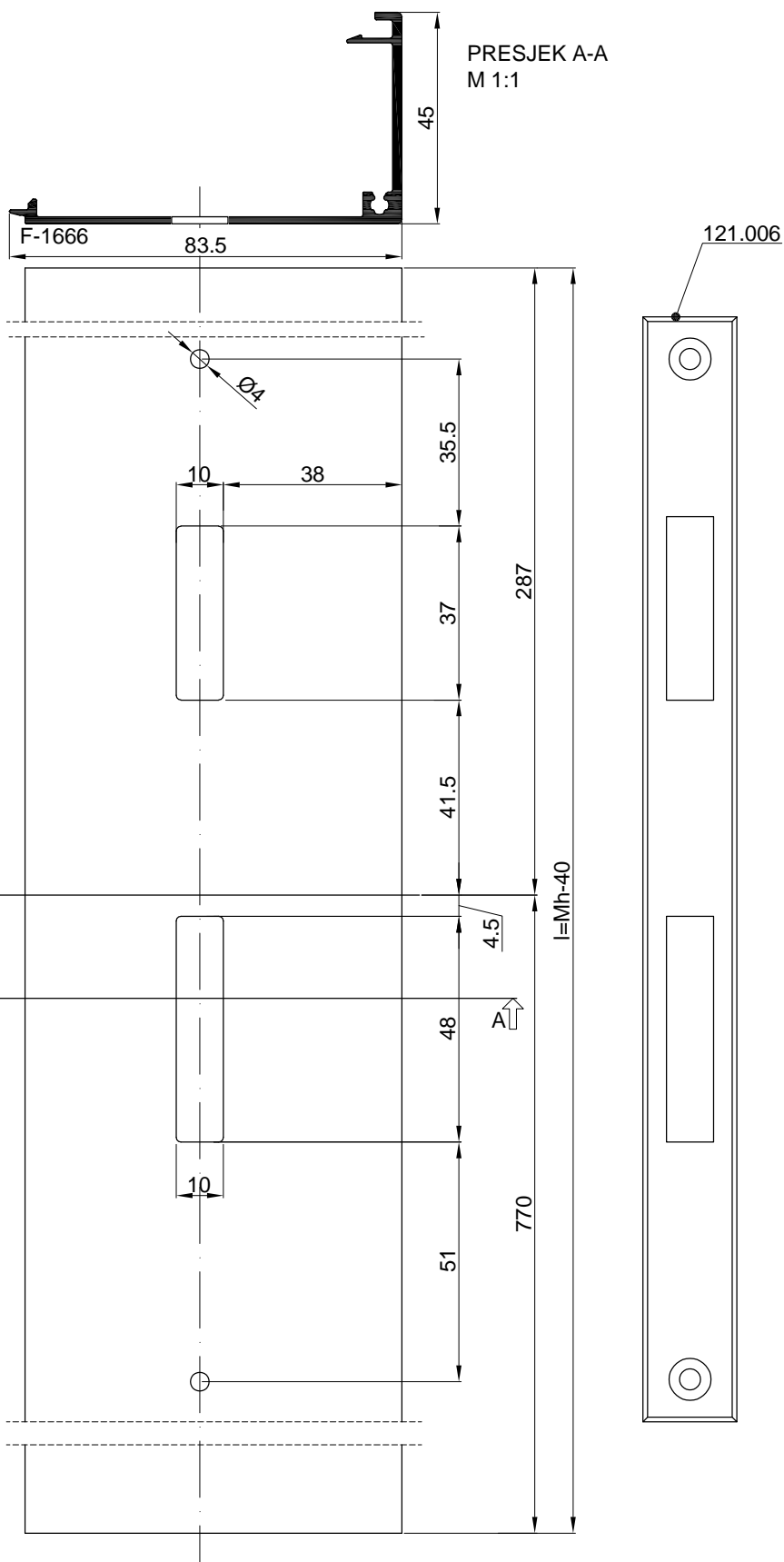
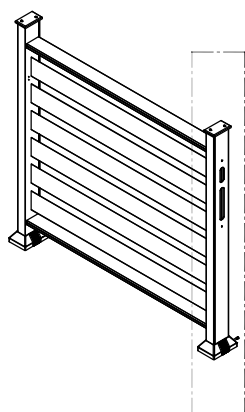

### OF-80 Tip KC-86

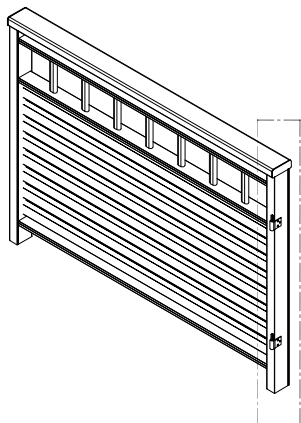

#### 11. Postupak obrade profila F-1666:

11.1. Izbušiti rupe  $\varnothing 5$  i  $\varnothing 4$  na vanjskom profilu F-1666 za prihvat baglame prema crtežu

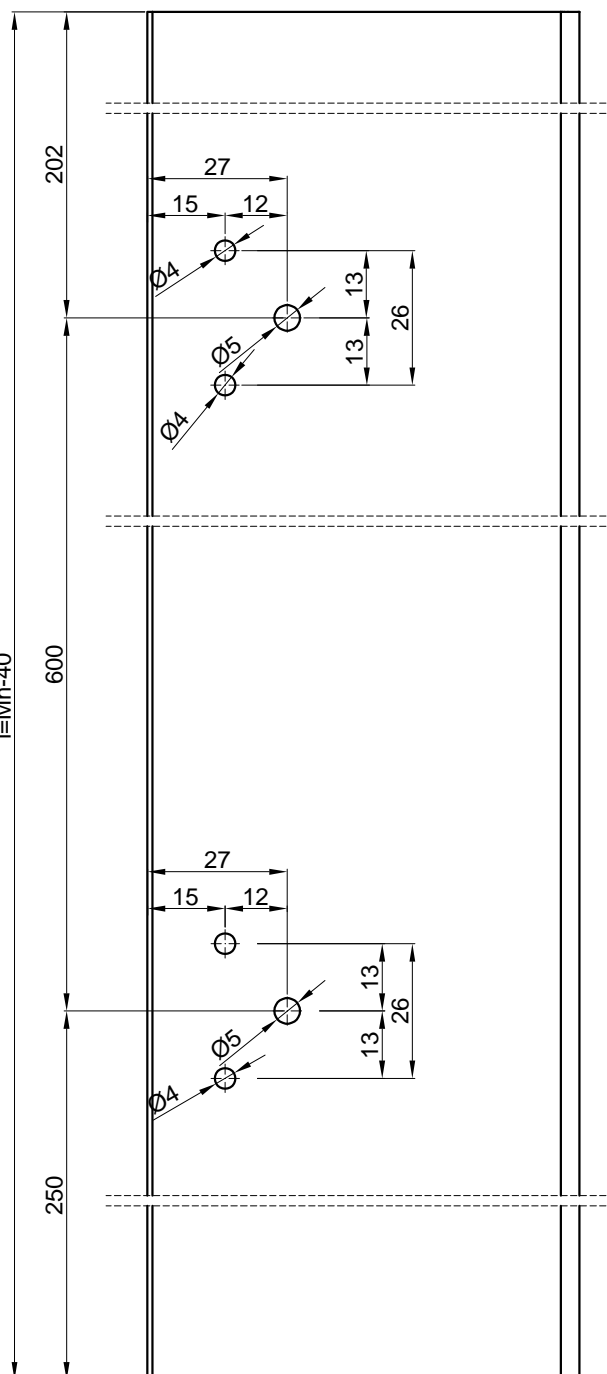
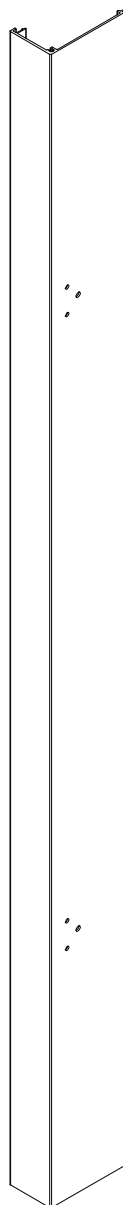
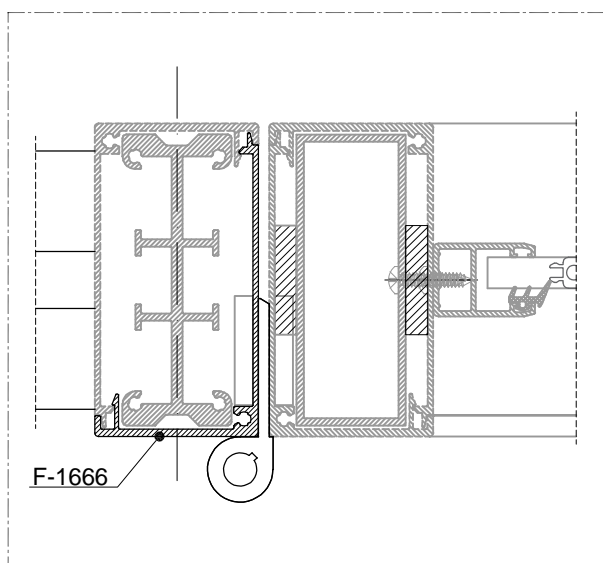
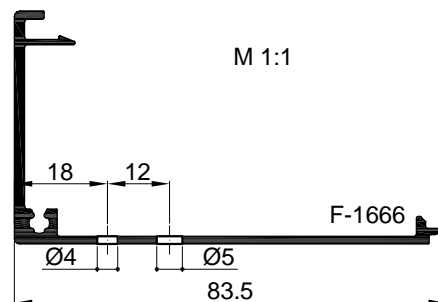

### OF-80 Tip KC-86

#### 12. Postupak obrade profila F-1667 i F-1666:

- 12.1. Na jednom profilu F-1667 izbušiti rupe  $\varnothing 5$  prema crtežu
- 12.2. Na profilu F-1666 izbušiti rupe  $\varnothing 5$  prema crtežu

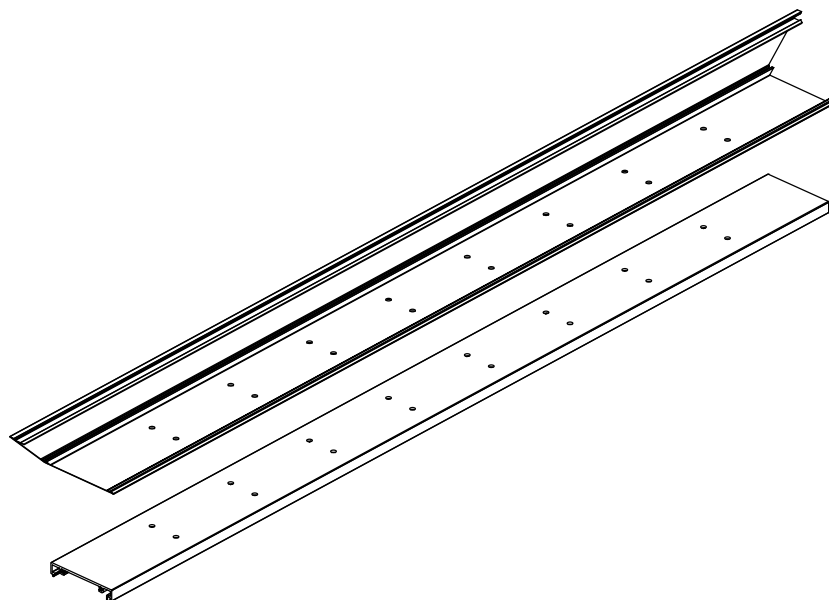
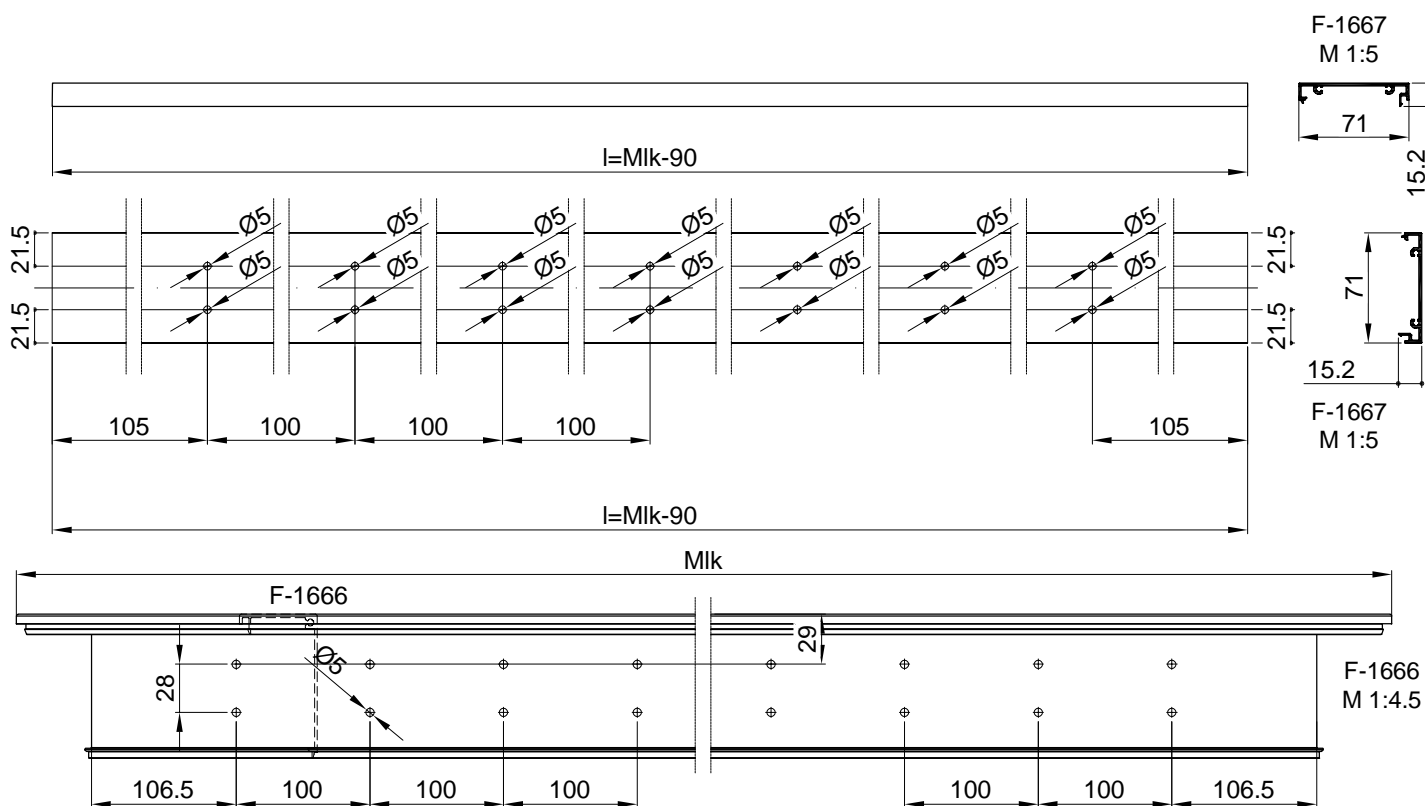
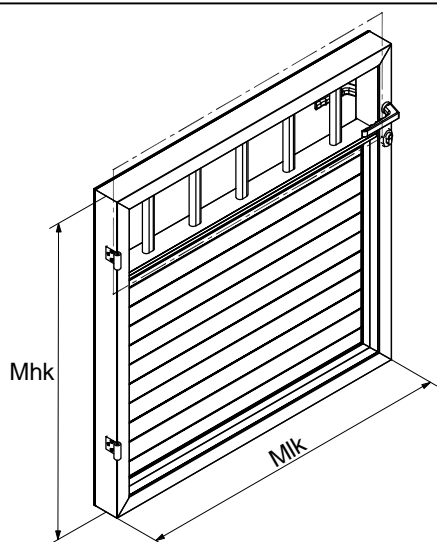

### OF-80 Tip KC-86

#### 13. Postupak montaže okvira profila F-1664:

- 13.1. Umetnuti brtve 321.002 u profile F-1664
- 13.2. Napraviti ram od profila F-1664 prema shemi

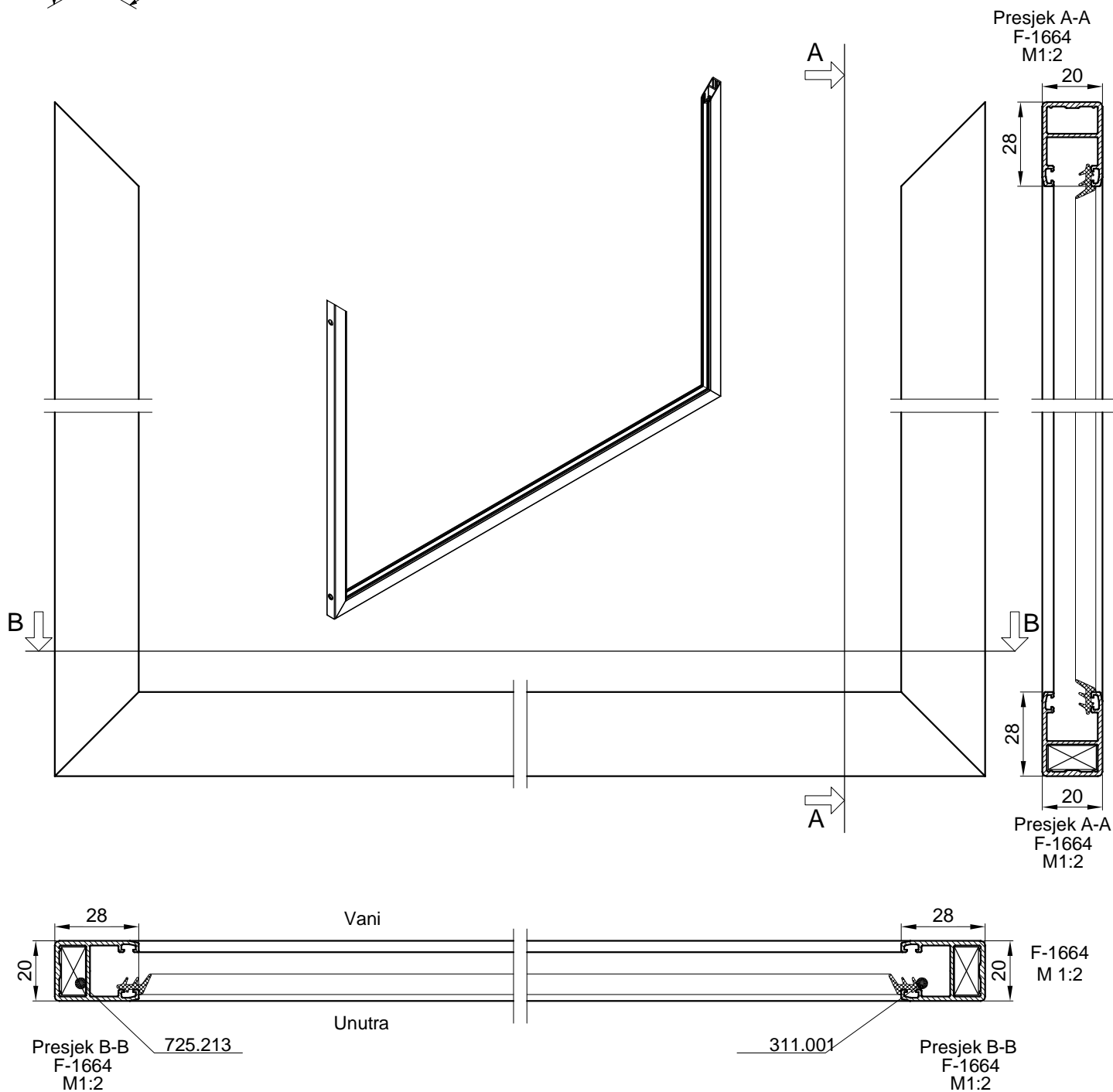
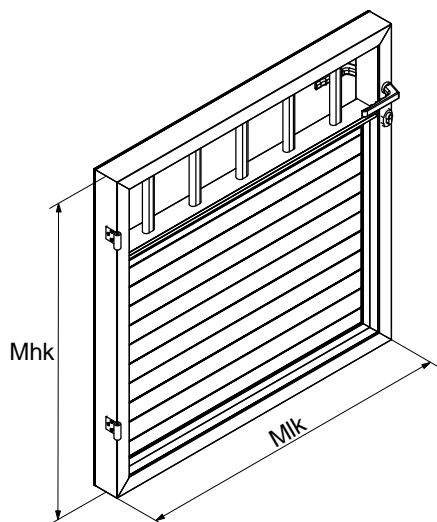

### OF-80 Tip KC-86

#### 14. Postupak umetanja ispune profila F-0714:

14.1. Umetnuti profile ispune F-0714 u okvir od profila F-1664 prema shemi

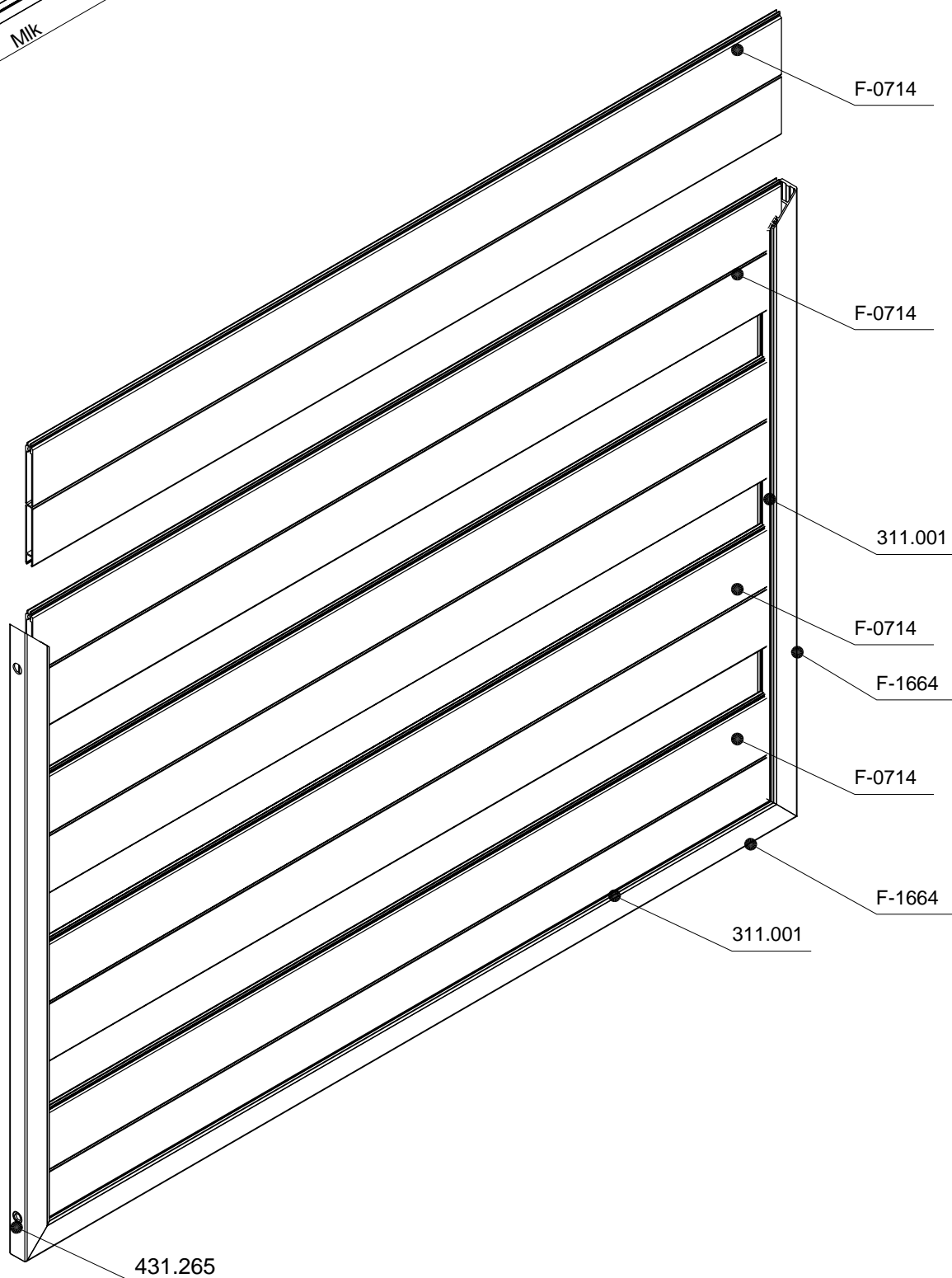
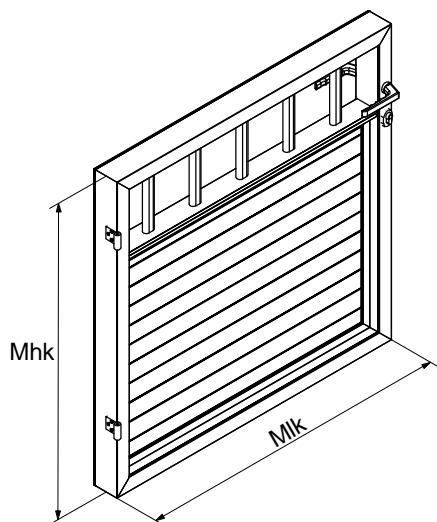

### OF-80 Tip KC-86

#### 15. Postupak završetka spajanja rama profila F-1664:

15.1. Spojiti gornji horizontalni pojas rama s donjim dijelom rama prema shemi

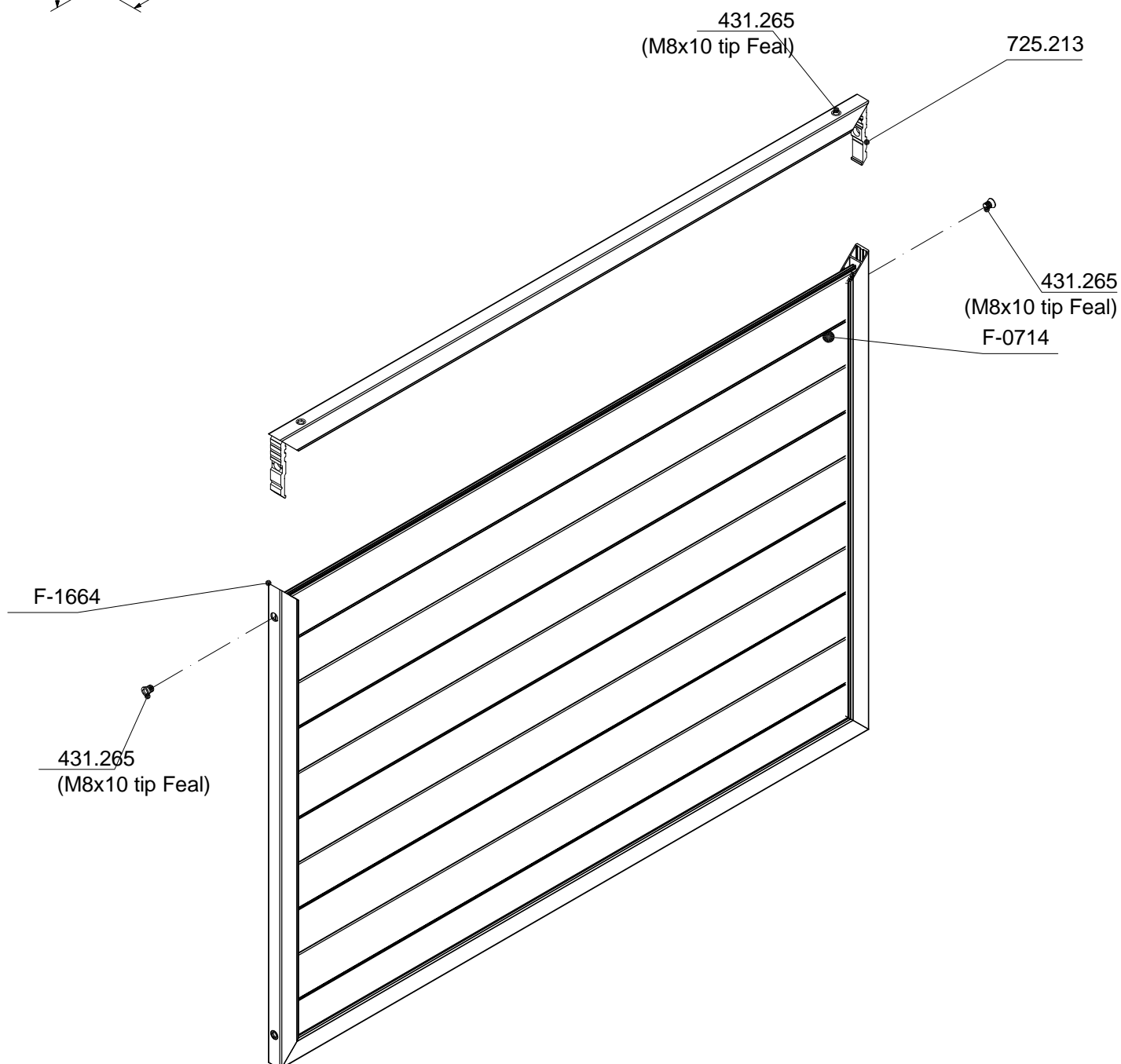
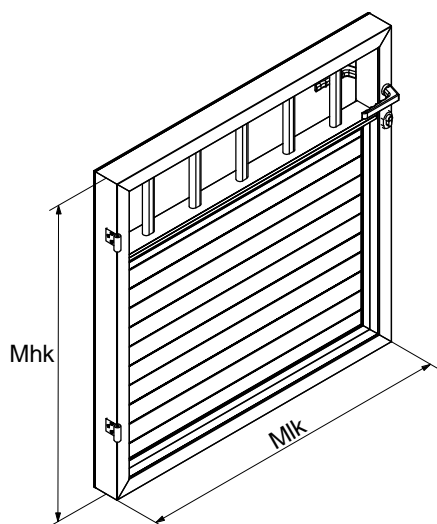

### OF-80 Tip KC-86

#### 16. Postupak montaže profila F-1666:

16.1. Unutarnji plašt kapije profili F-1666 vežemo za ispunu F-1664 pomoću vijaka 433.016 (3.9x13 DIN 7981) prema shemi

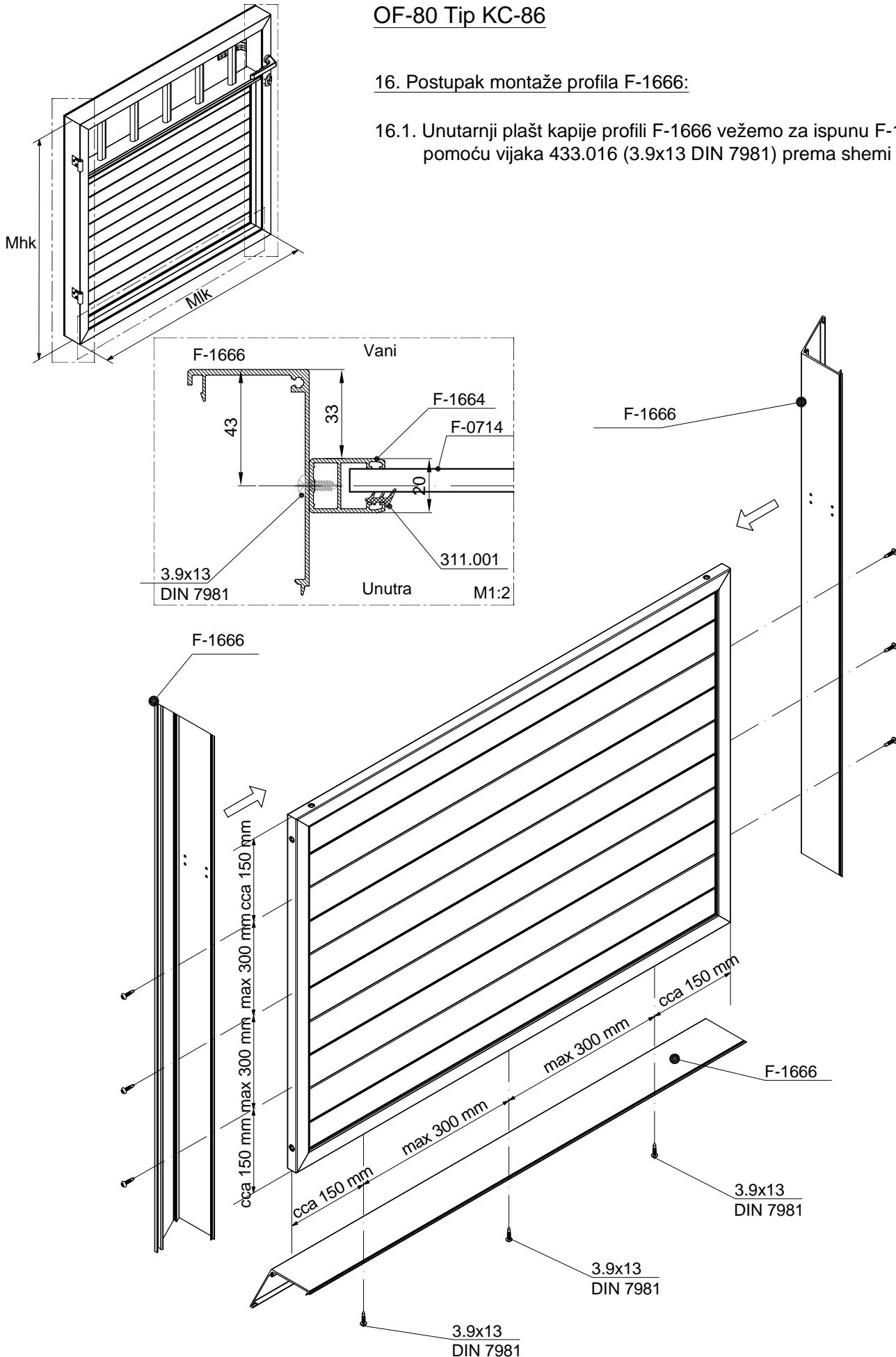

OF-80 Tip KC-86

17. Postupak spajanja gornjeg dijela segmenta kapije s donjim dijelom segmenta kapije:

17.1. Umetanje gornjeg dijela kapije u okvir prema shemi

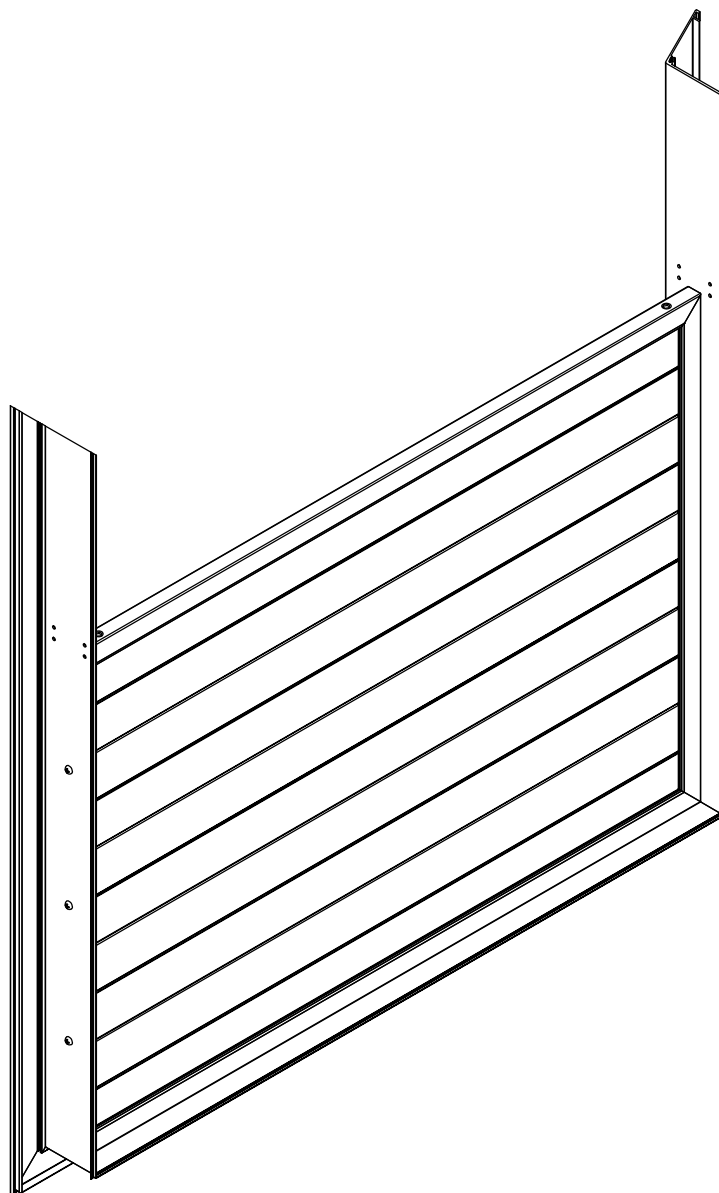
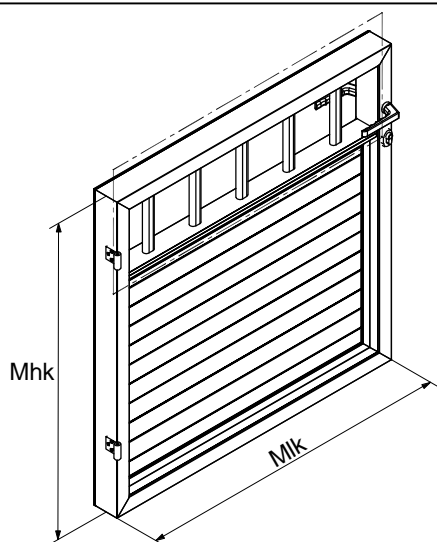

### OF-80 Tip KC-86

#### 18. Postupak spajanja profila F-1667, F-1666 i OG-111:

##### 18.1. Montaža profila OG-111 između profila F-1666 i F-1667 prema shemi

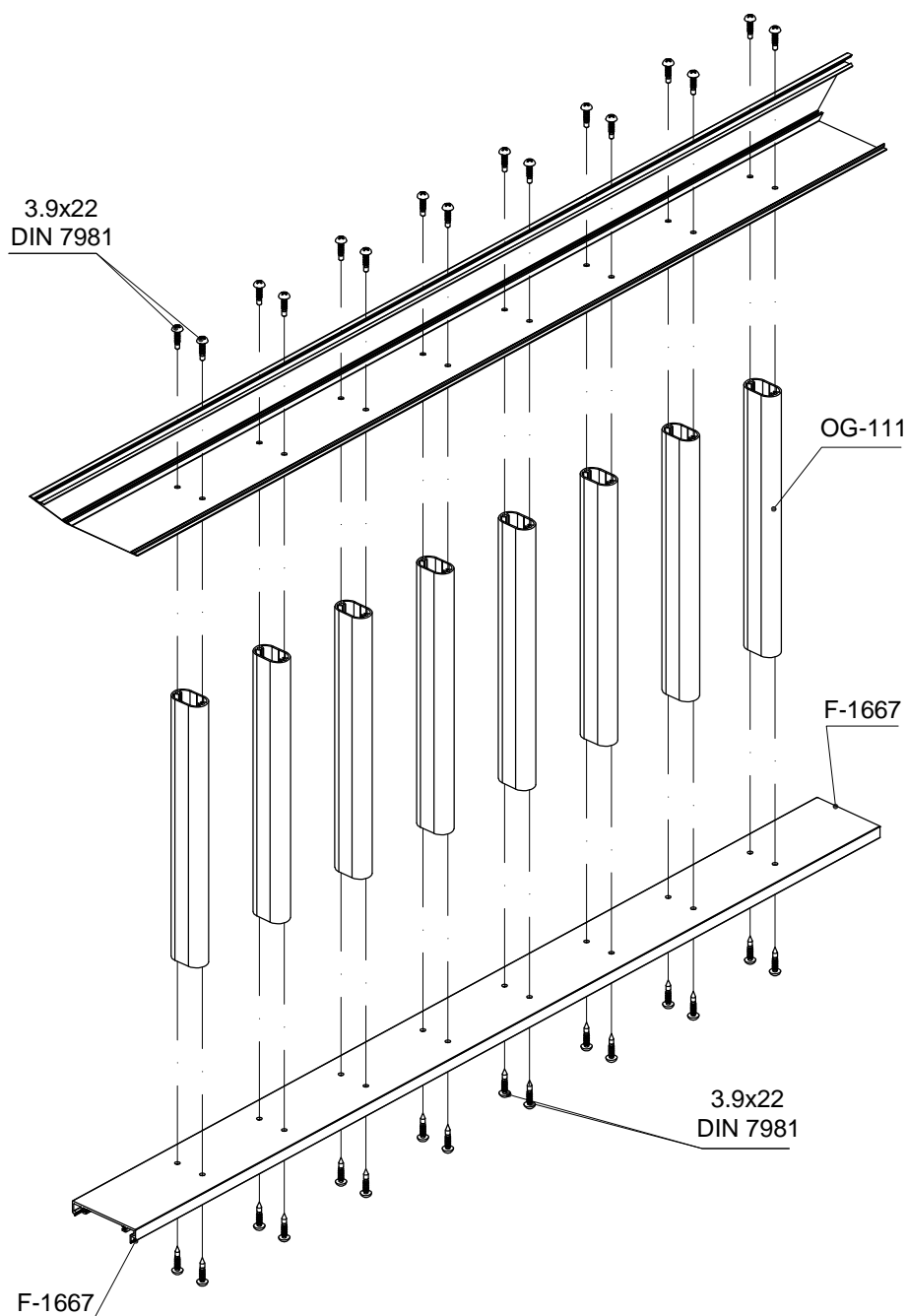
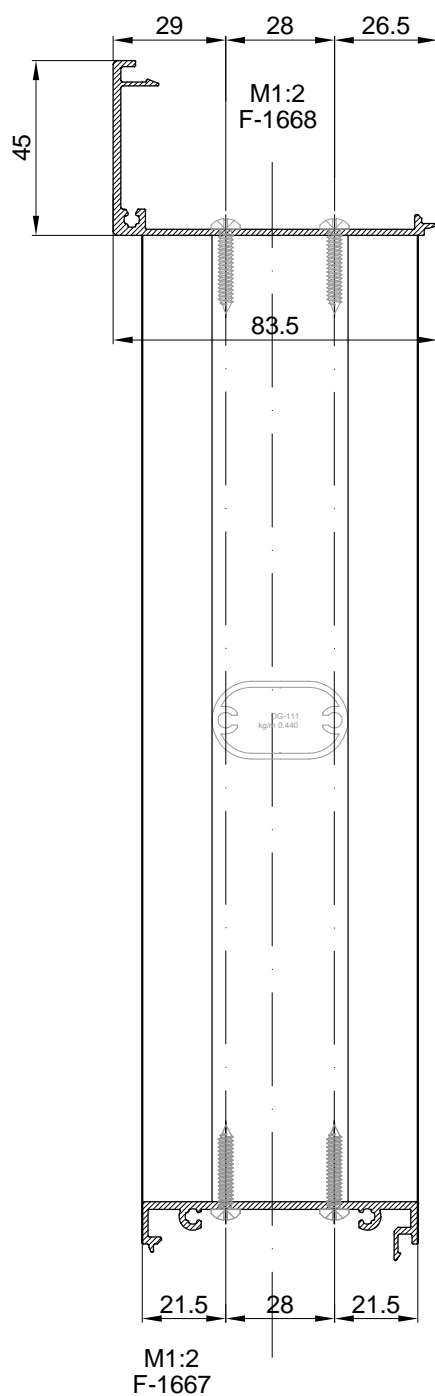
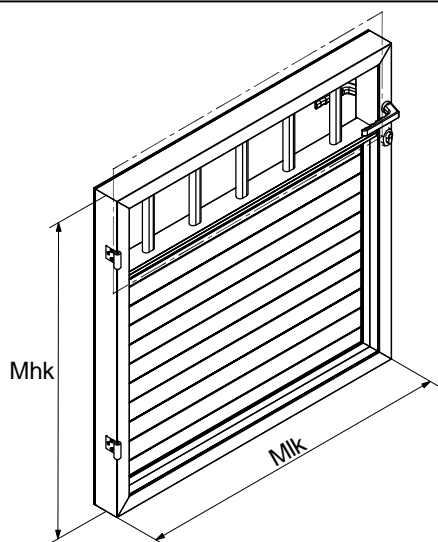

### OF-80 Tip KC-86

19. Postupak spajanja gornjeg dijela segmenta kapije s donjim dijelom segmenta kapije:

19.1. Umetanje gornjeg dijela kapije u okvir prema shemi

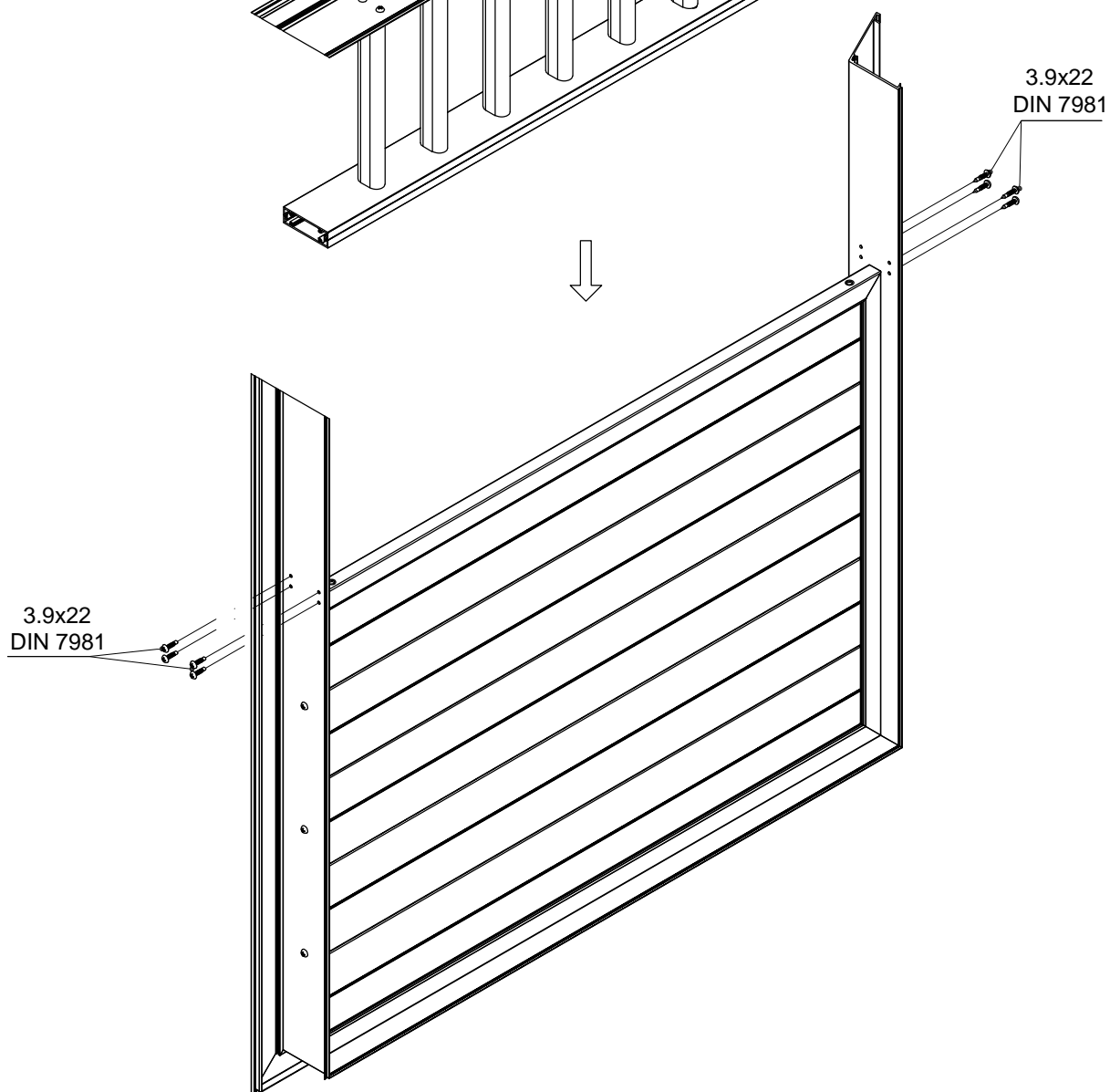
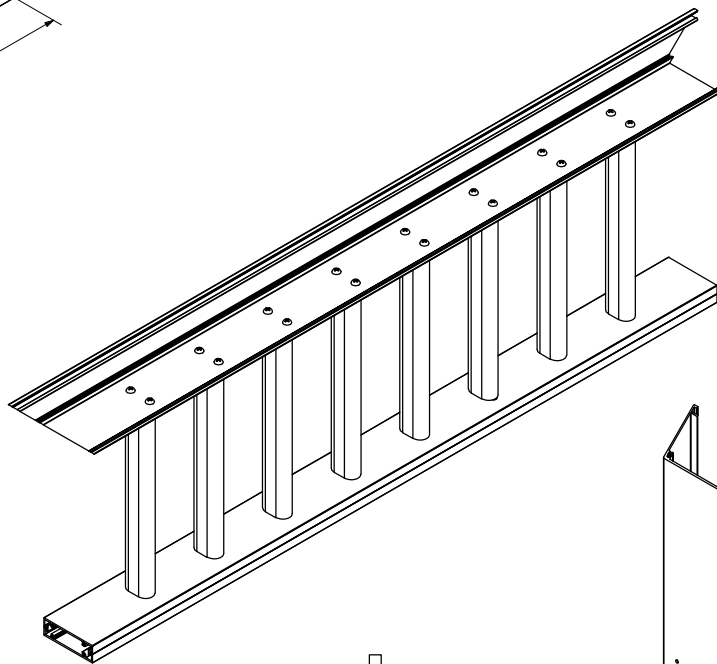
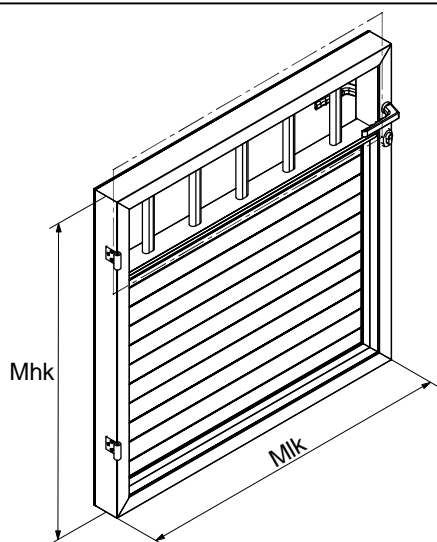

OF-80 Tip KC-86

20. Postupak spajanja gornjeg dijela segmenta kapije s donjim dijelom segmenta kapije:

20.1. Umetanje gornjeg dijela kapije u okvir prema shemi

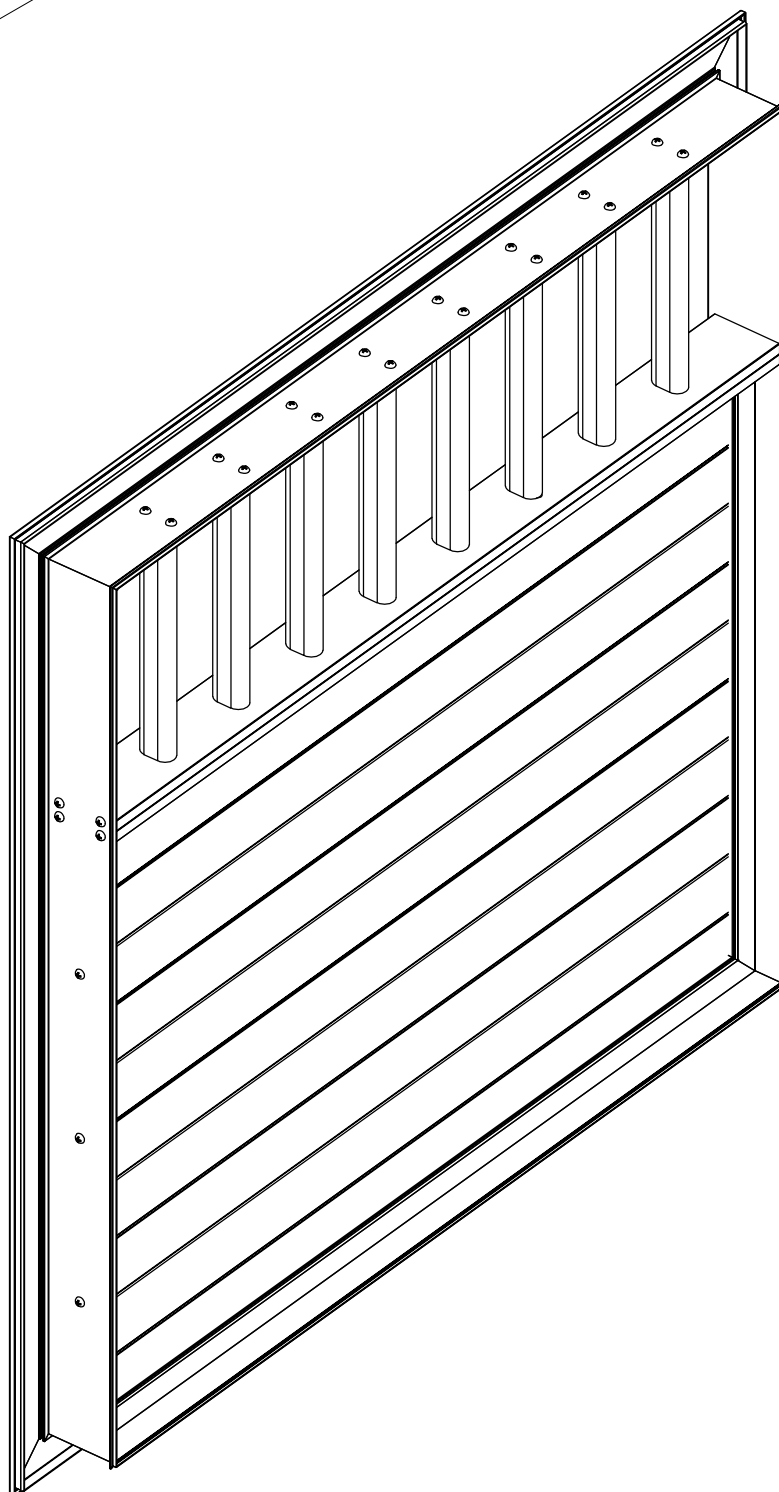
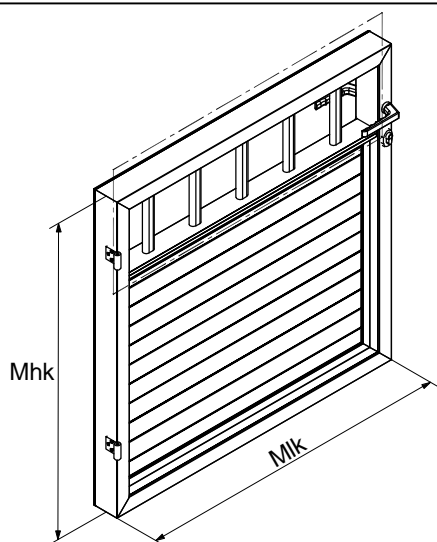

### OF-80 Tip KC-86

#### 21. Postupak spajanja rama moždanika F-0441:

##### 21.1. Umetanje kutnih spojnica 710.544 u komore moždanika F-0441

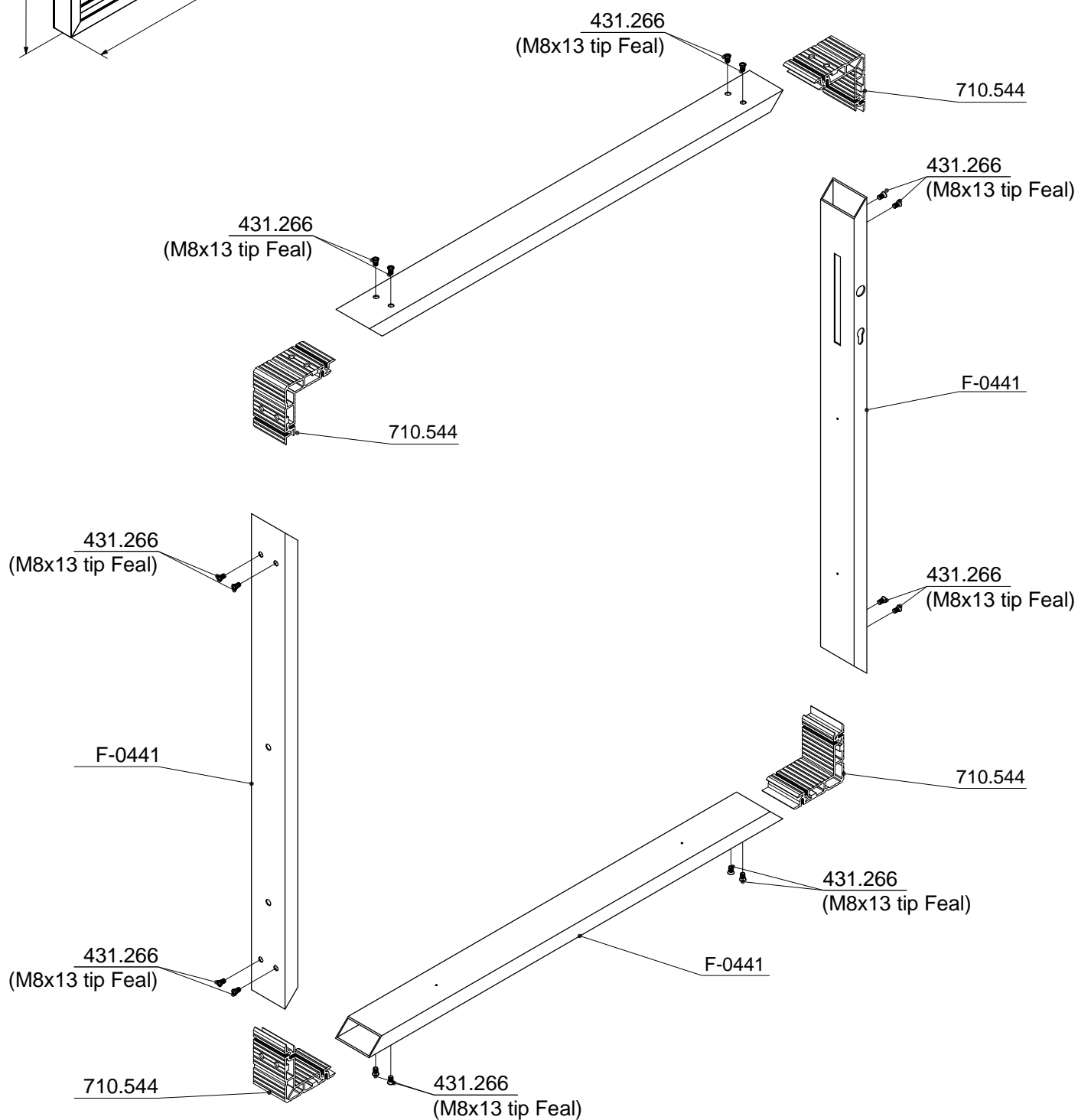
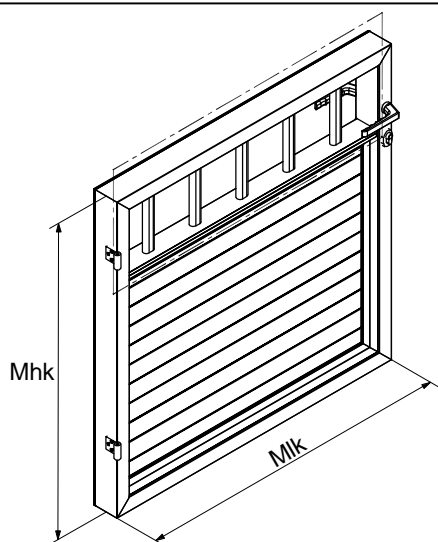

### OF-80 Tip KC-86

#### 22. Postupak montaže moždanika rama F-0441:

- 22.1. Ljepimo trenutnim ljepilom PVC distancere 370.034 po unutarnjem plaštu kapije
- 22.2. U okvir rama profila F-1666 umetnemo moždanik rama F-0441 i vežemo vijcima 433.018 (3.9x19 DIN 7981)

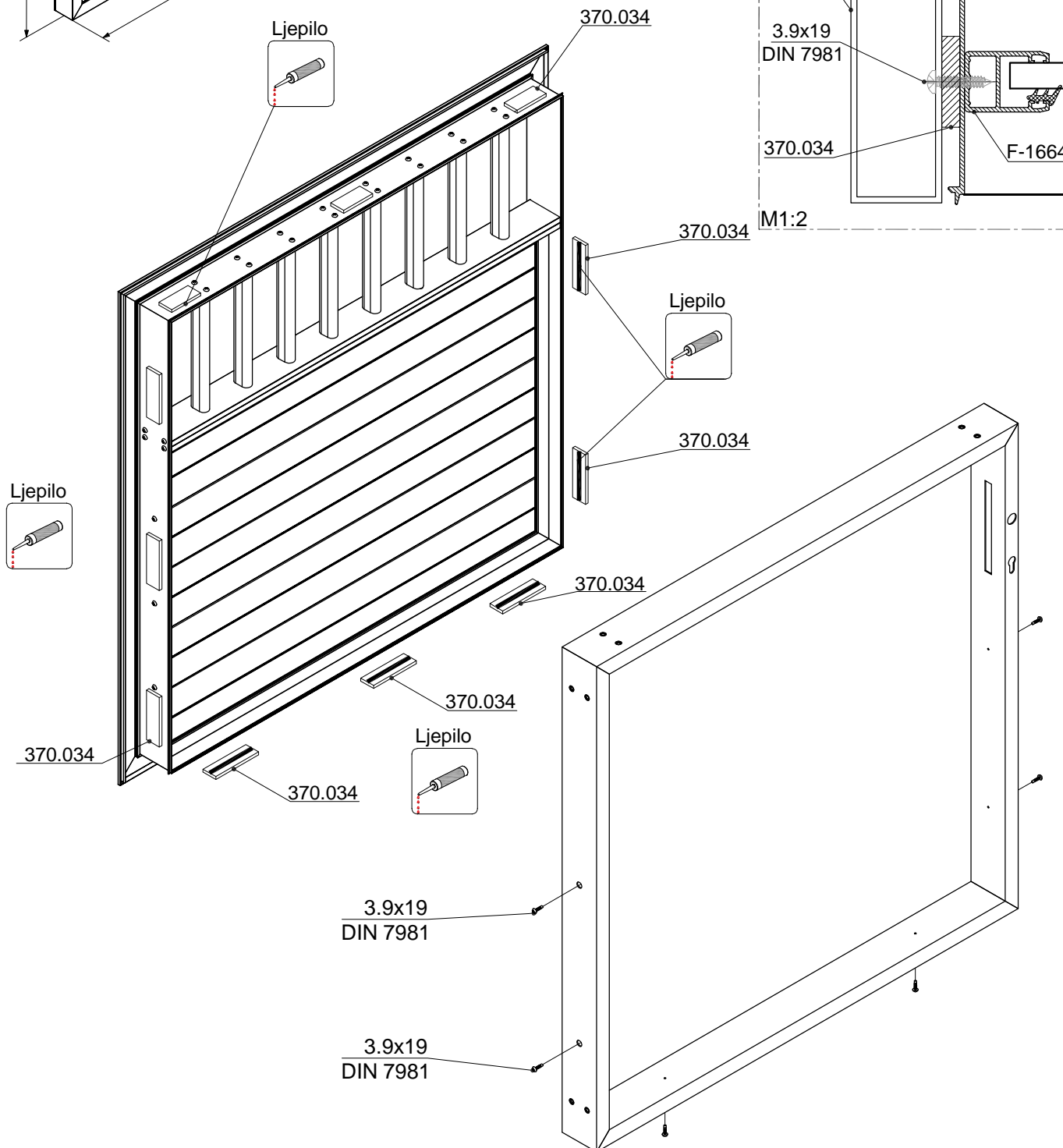
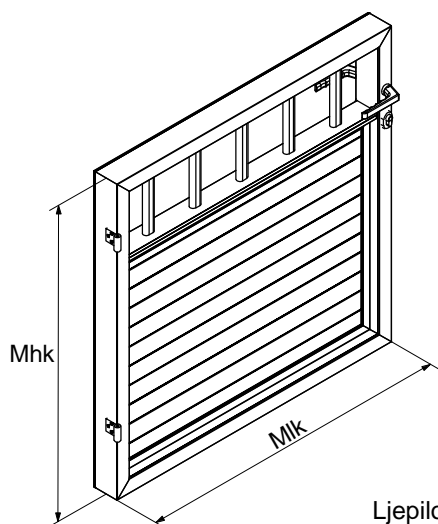

### OF-80 Tip KC-86

#### 23. Postupak montaže moždanika rama F-0441:

##### 23.1. Izgled montiranog moždanika

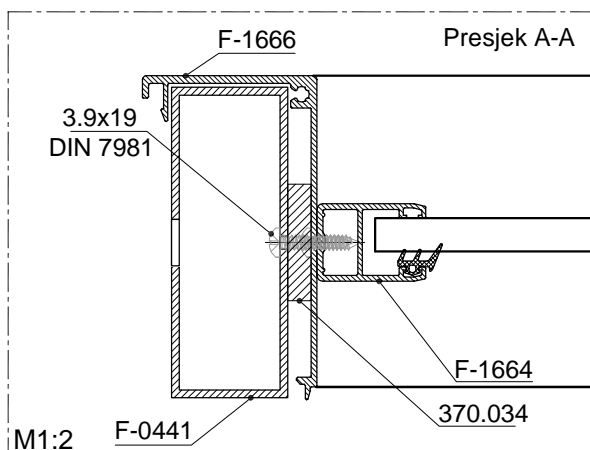
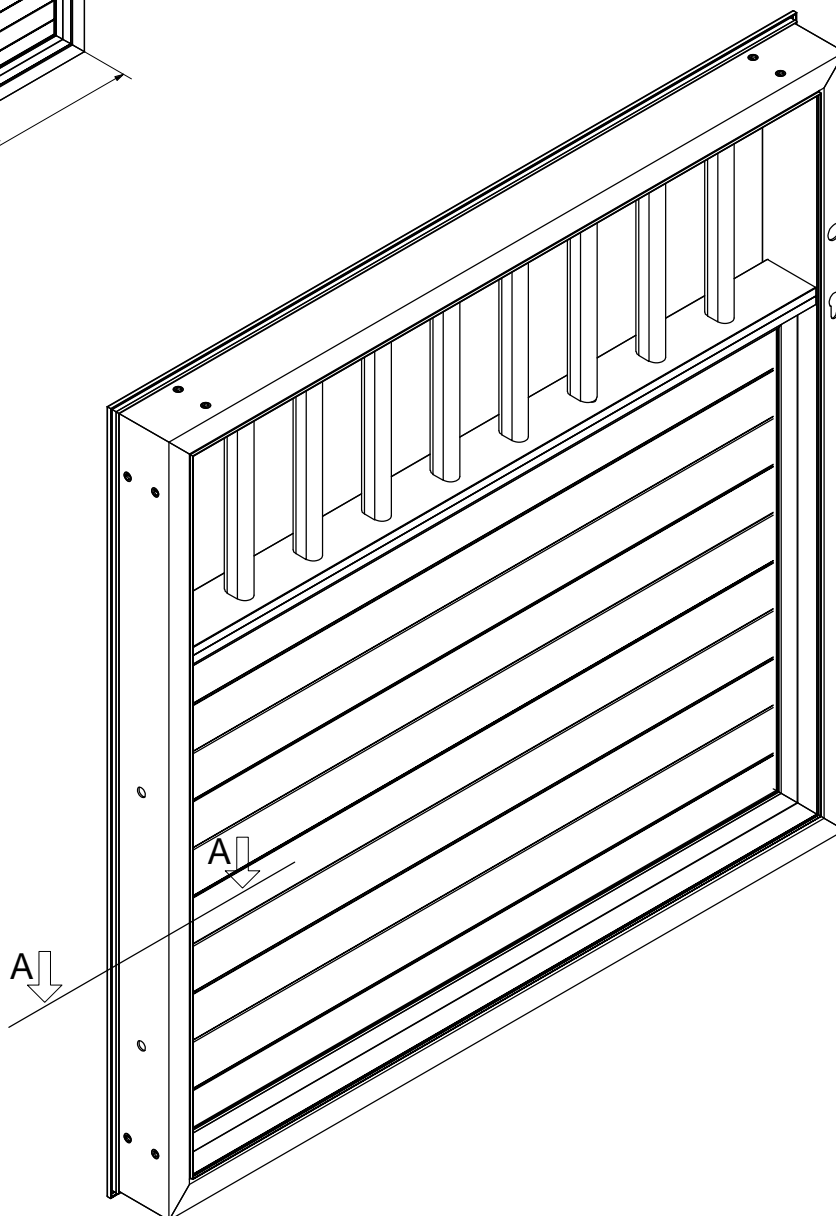
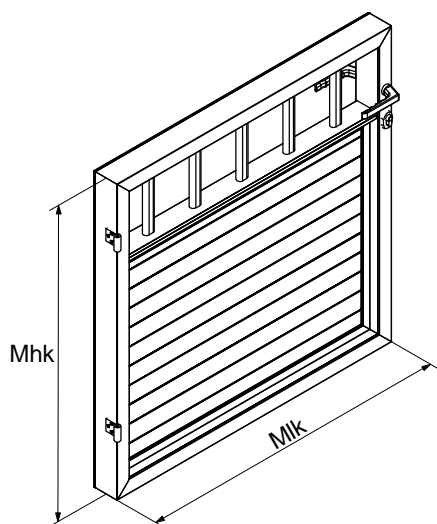

#### OF-80 Tip KC-86

#### 26. Postupak montaže vanjskog plašta kapije:

- 26.1. Na ram moždanika lijepimo PVC distancere 370.034
- 26.2. Na unutarnji plašt kapije klipsamo vanjski plašt kapije profila F-1666 prema crtežu

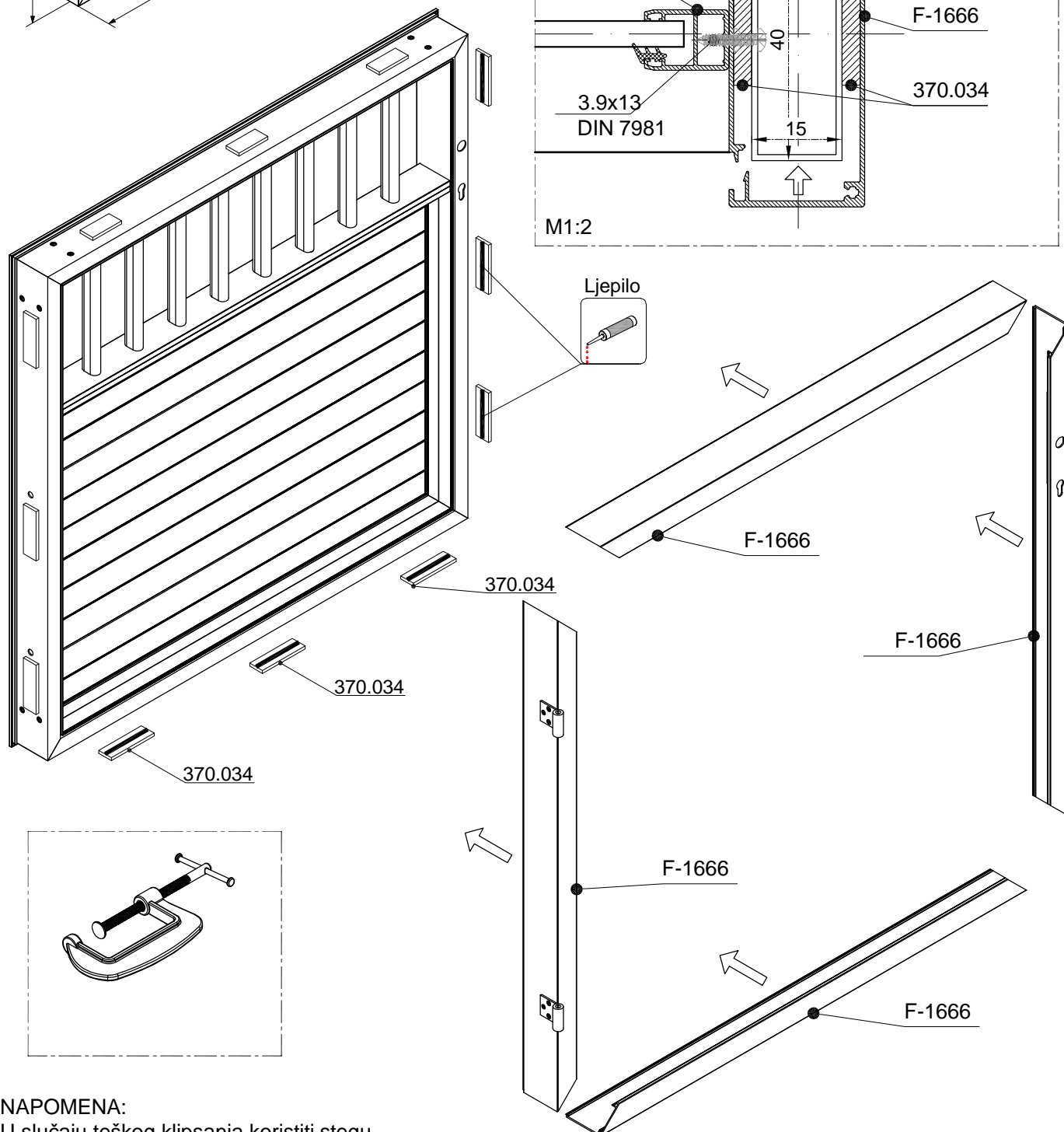
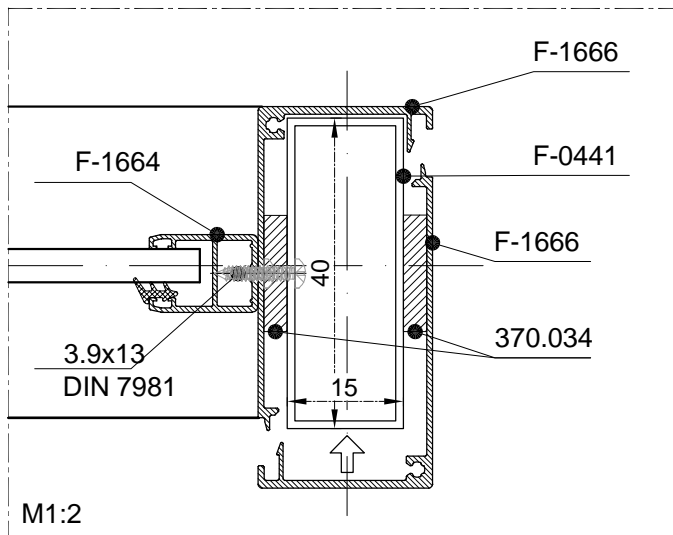
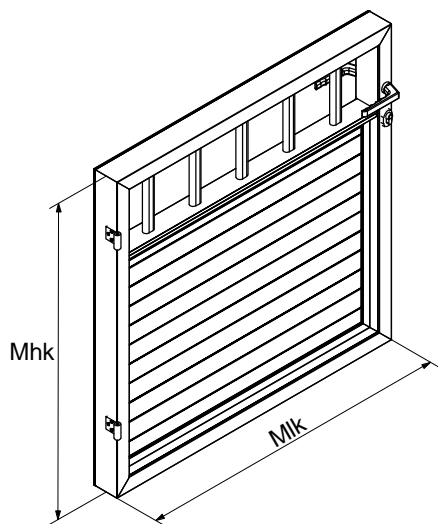

**NAPOMENA:**  
U slučaju teškog klipsanja koristiti stegu.

### OF-80 Tip KC-86

#### 27. Postupak montaže vanjskog plašta kapije:

- 27.1. Na unutarnji plašt kapije klipsamo vanjski plašt kapije profila F-1666 prema crtežu
- 27.2. U slučaju težeg klipsanja koristimo stegu

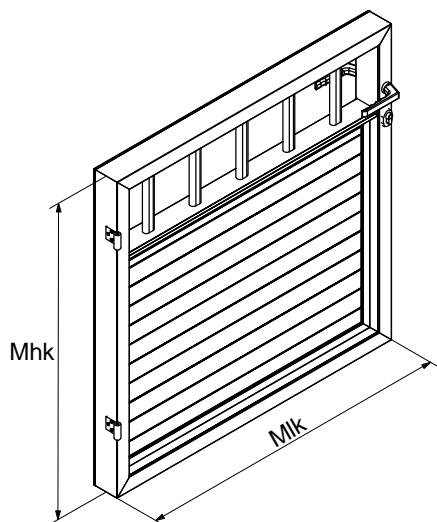

M1:2

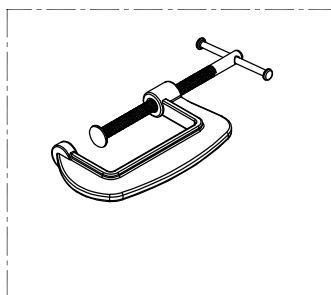
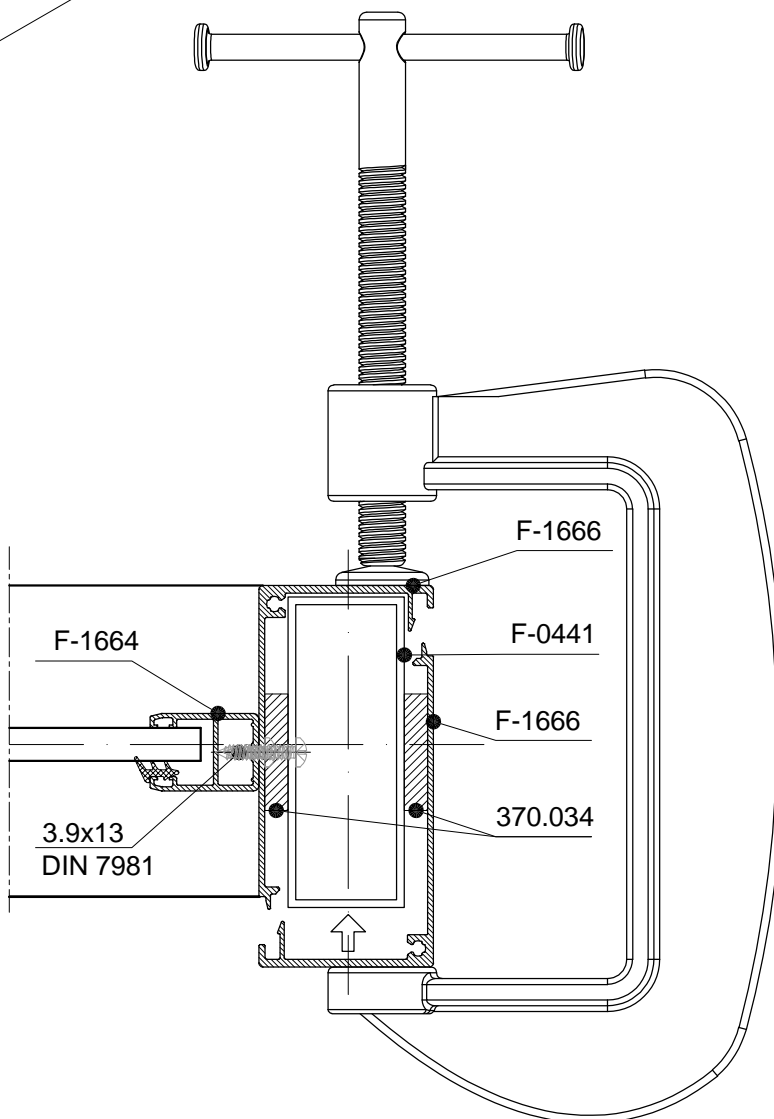

**NAPOMENA:**

U slučaju težeg klipsanja koristiti stegu.

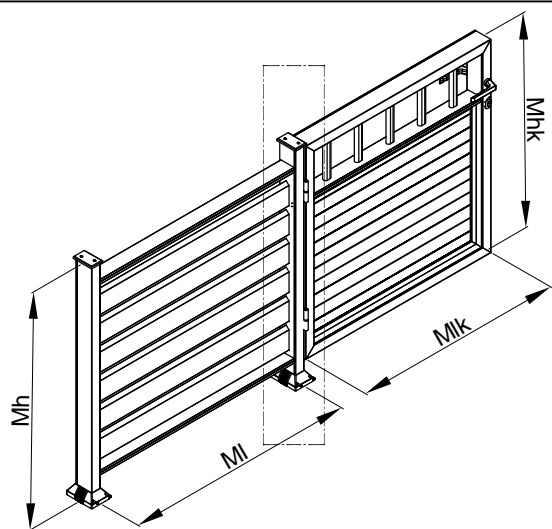

### OF-80 Tip KC-86

24. Položaj ugradnje baglama:

24.1. Montirati baglame na kapiju i ogradu prema crtežu.

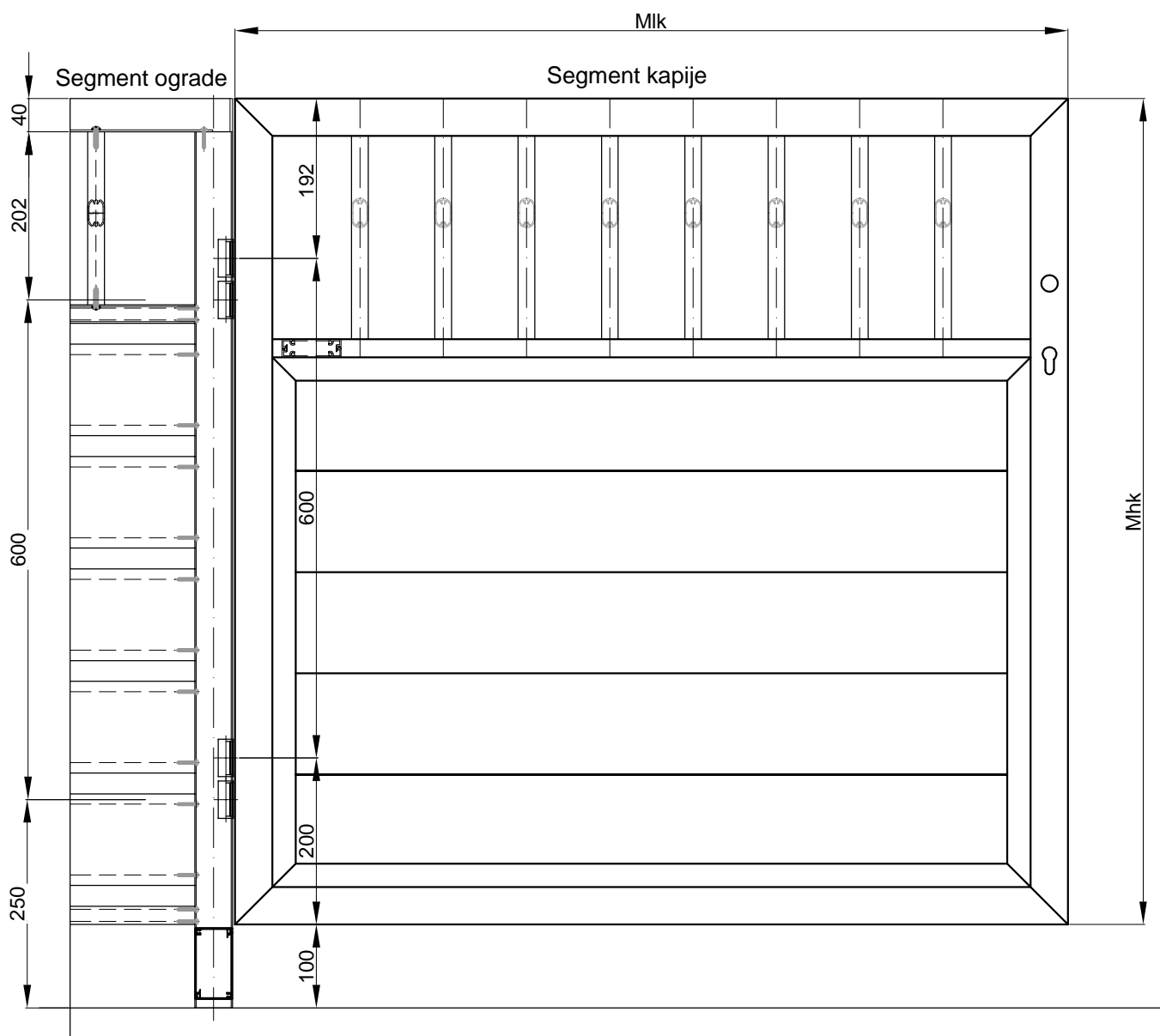

#### OF-80 Tip KC-86

#### 25. Postupak ugradnje baglama na segment ograde:

25.1. Baglame (111.027) vežemo za moždanik kroz profile F-1666 vijkom 4.8x32 DIN 7982

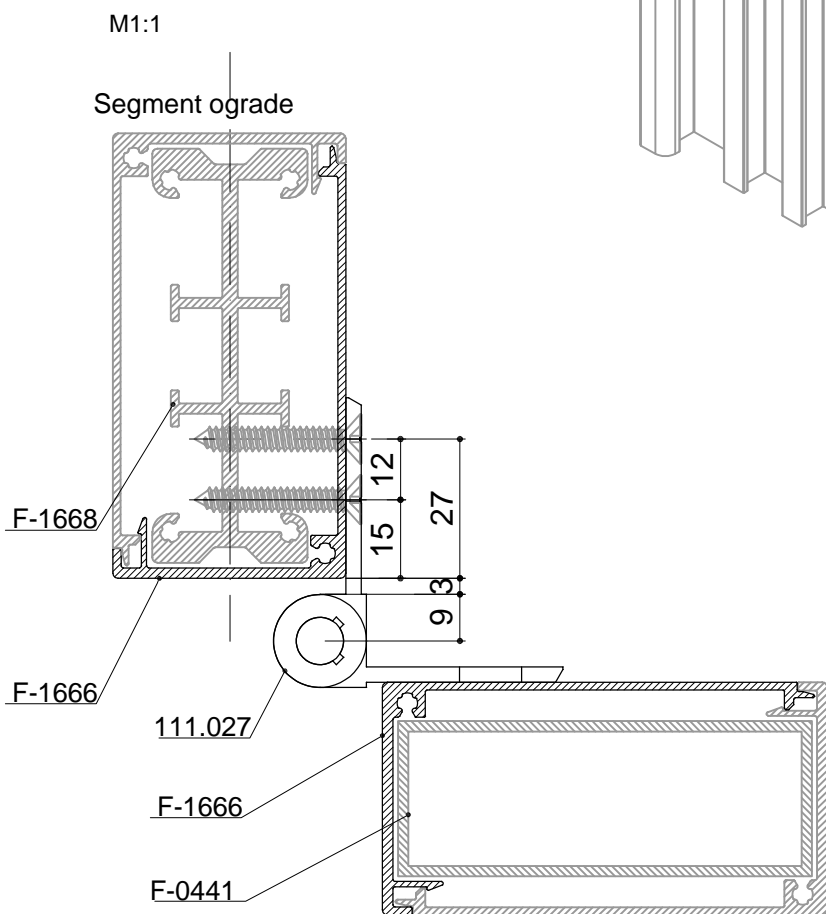
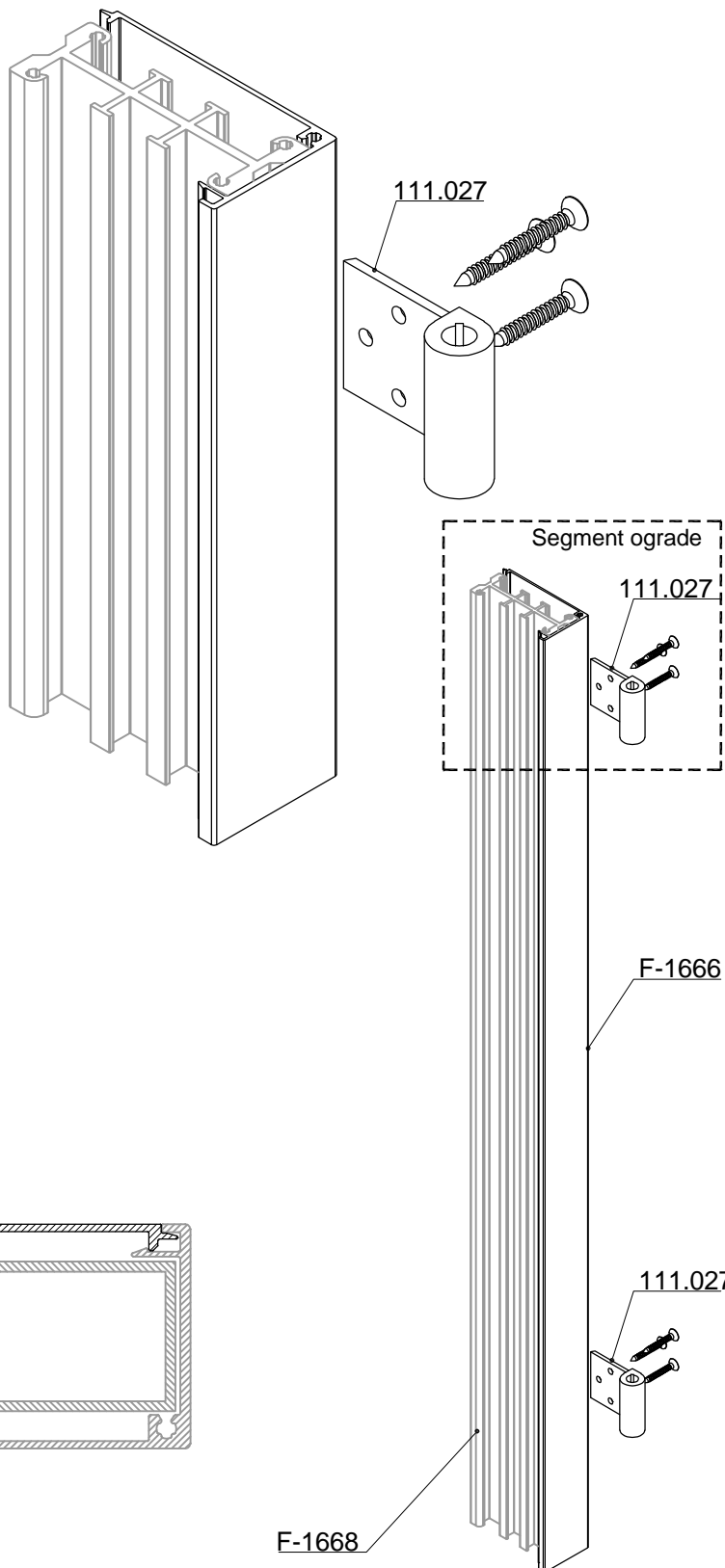
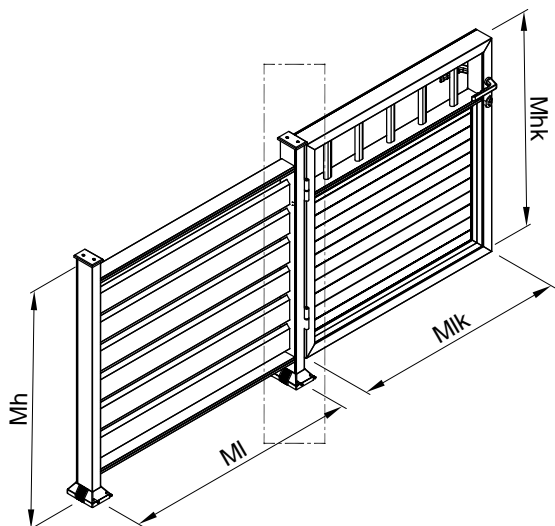

### OF-80 Tip KC-86

#### 25. Postupak ugradnje baglama na kapiju:

25.1. Baglame (111.027) vežemo za moždanik kroz profile F-1666 vijkom 4.8x32 DIN 7982

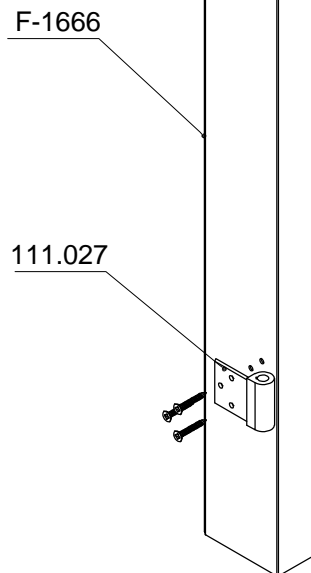
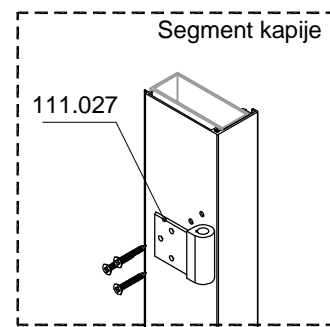
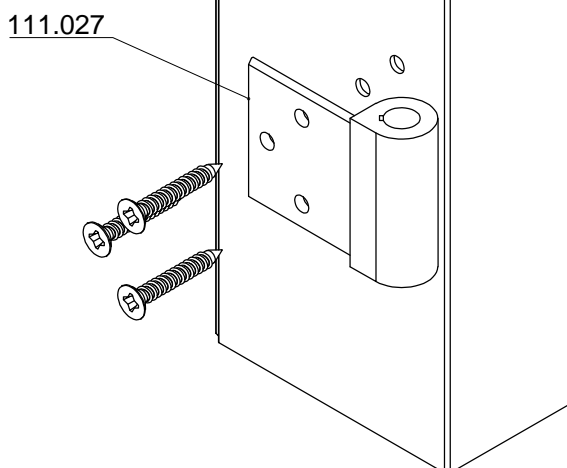
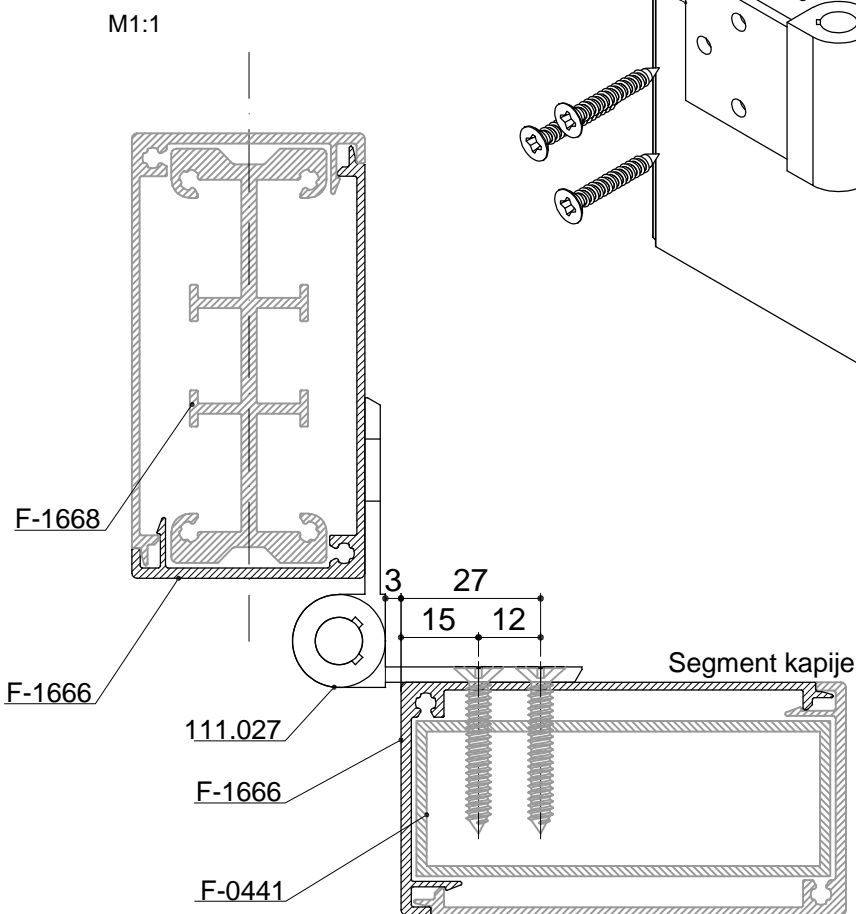
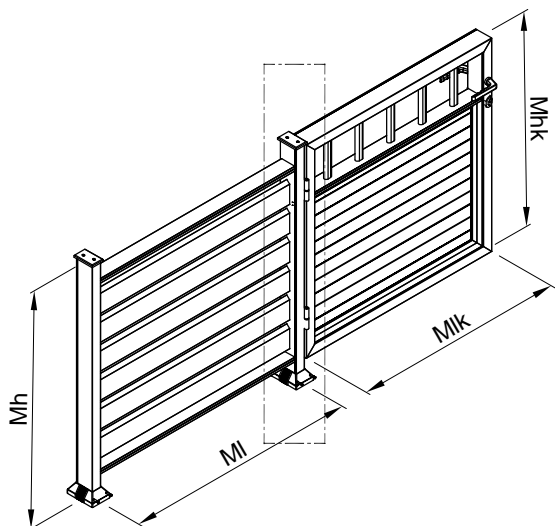

#### OF-80 Tip KC-86

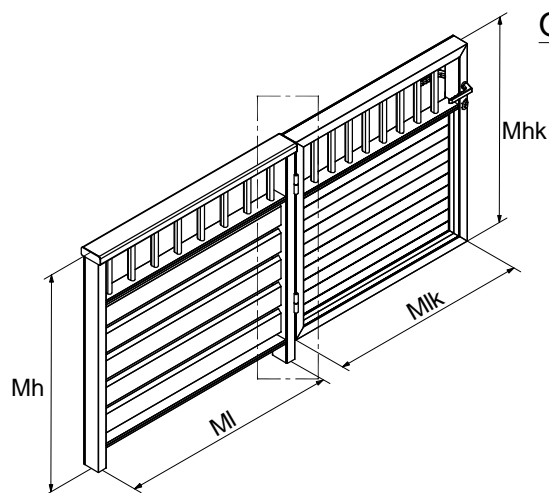

Mhk 28. Postupak ugradnje baglama na kapiju:

28.1. Baglame 111.027 pričvrstiti na kapiju vijcima 433.133 (4.8x32 DIN 7982) prema crtežu.

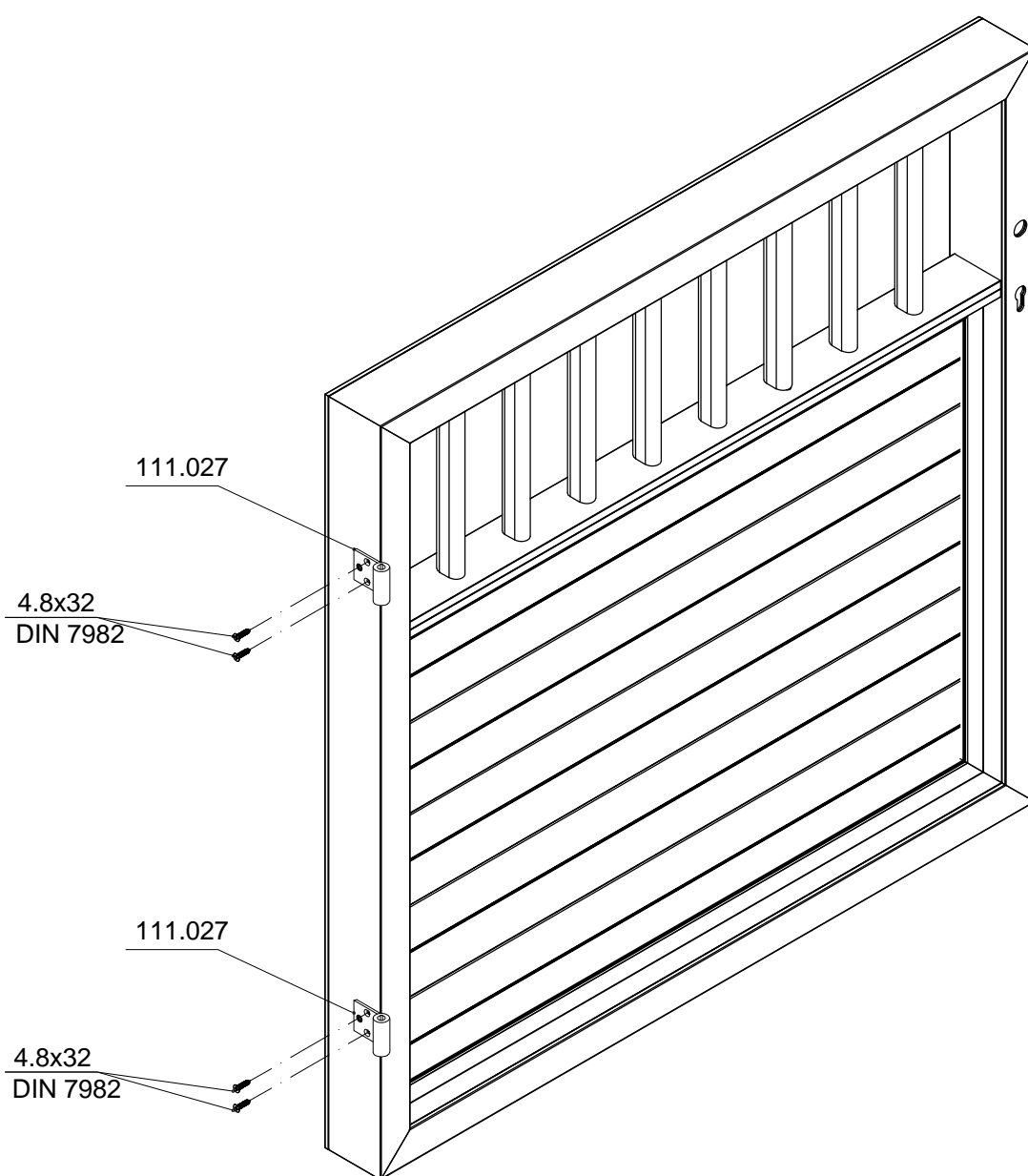

### OF-80 Tip KC-86

#### 30. Postupak montaže brave na kapiju:

##### 30.1. Montiramo bravu prema shemi

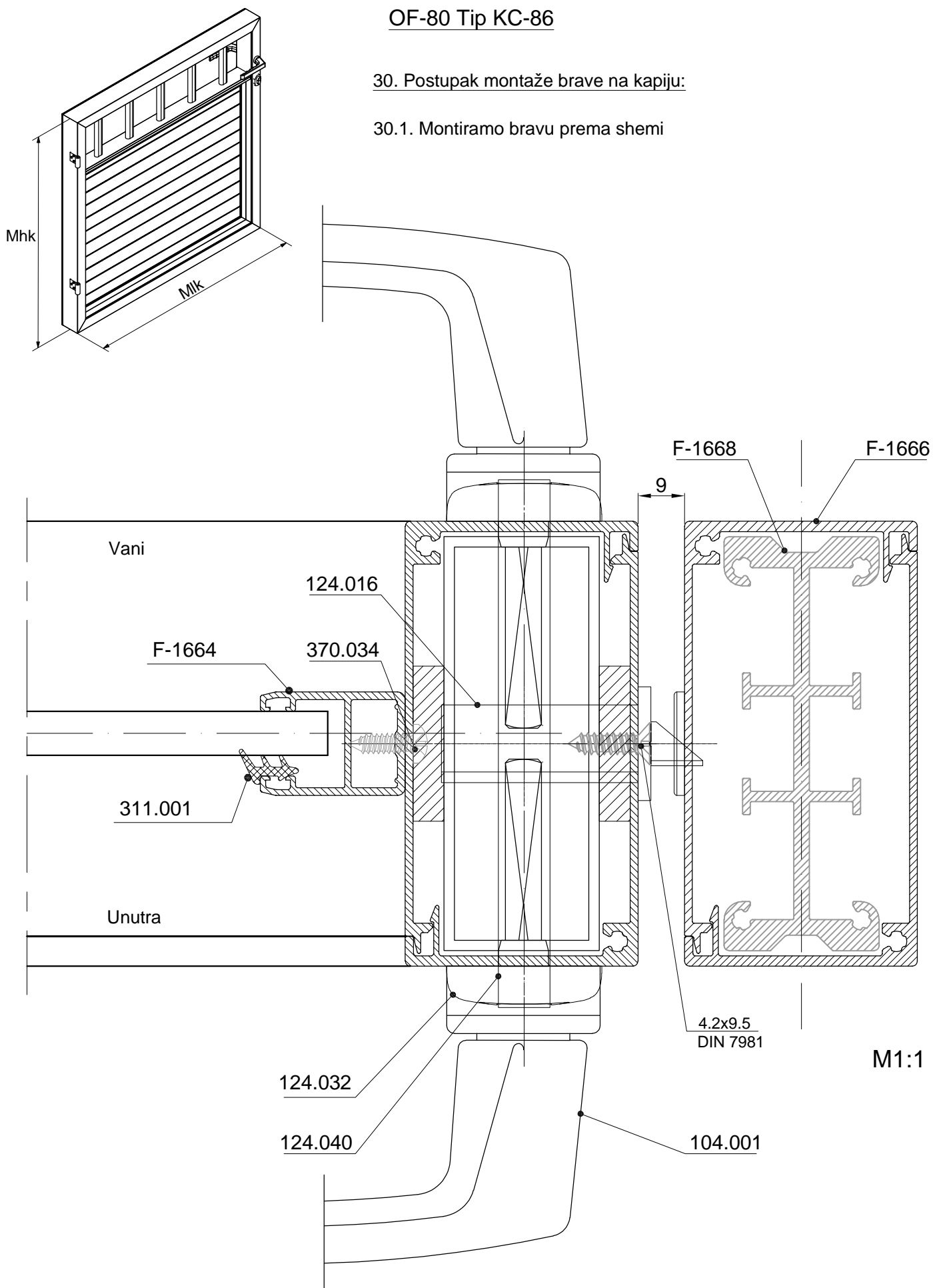

### OF-80 Tip KC-86

#### 29. Postupak montaže brave na kapiju:

##### 29.1. Montiramo bravu prema shemi

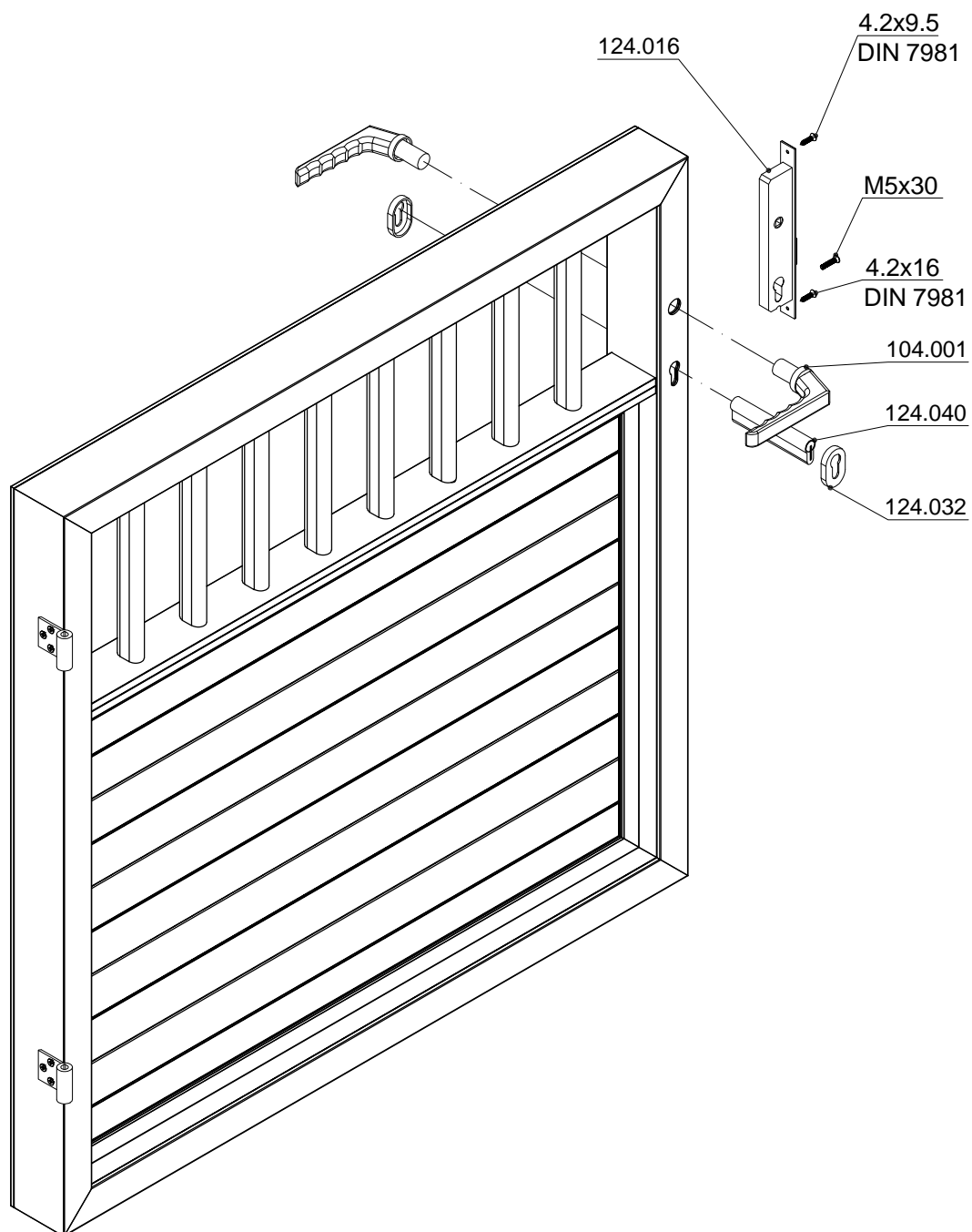
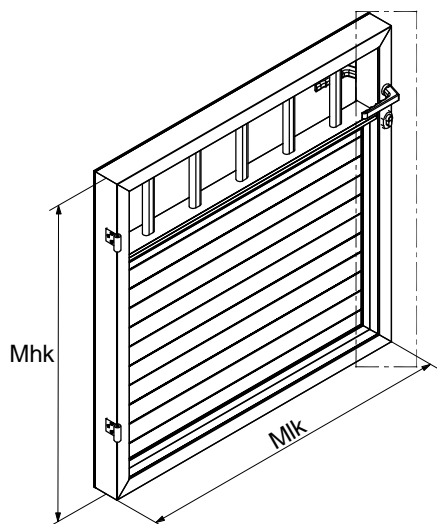

### OF-80 Tip KC-86

31. Postupak montaže brave na kapiju:

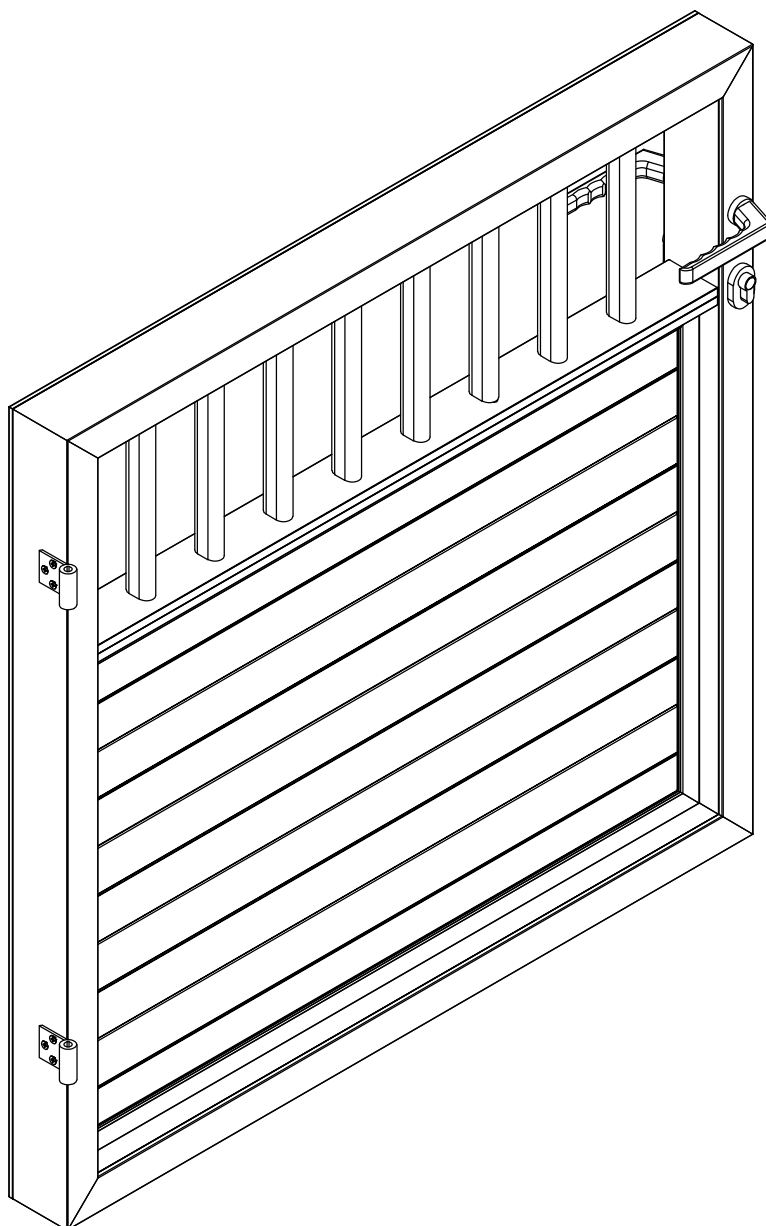
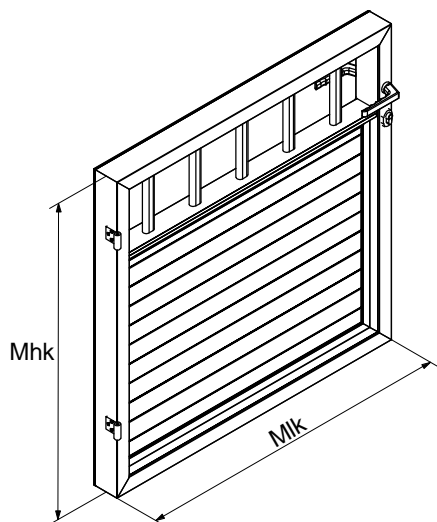

OF-80 Tip KC-8632. Postupak montaže kapije:

## 32.1. Montiramo kapiju na segment ograde

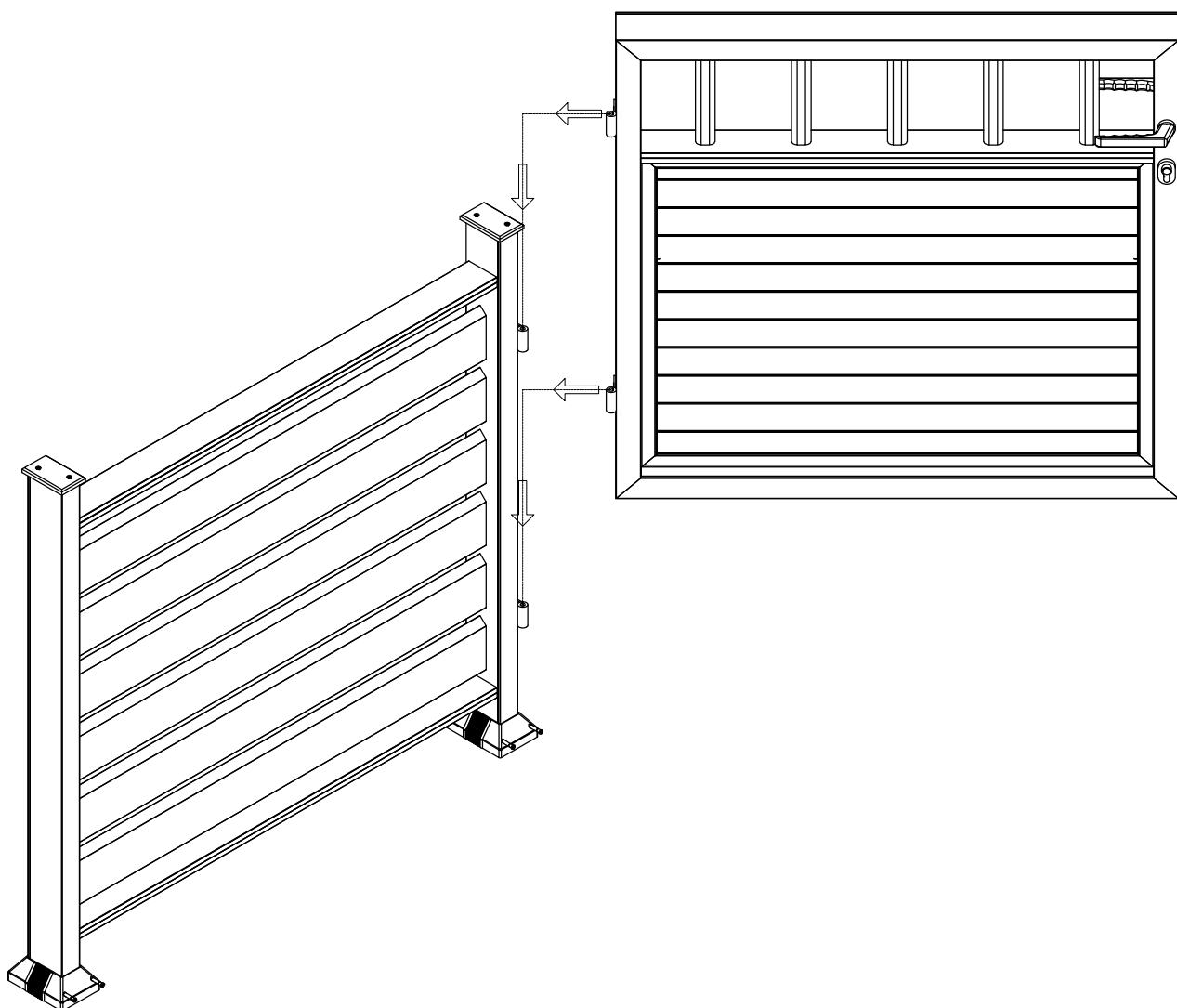
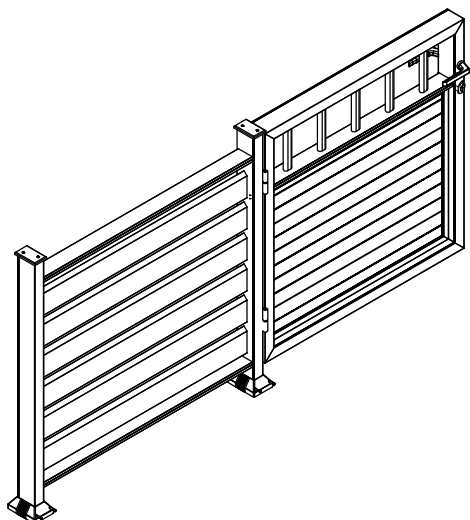

# OBRADA I MONTAŽA KAPIJE TIP KC-45

### OF-80 Tip KC-45

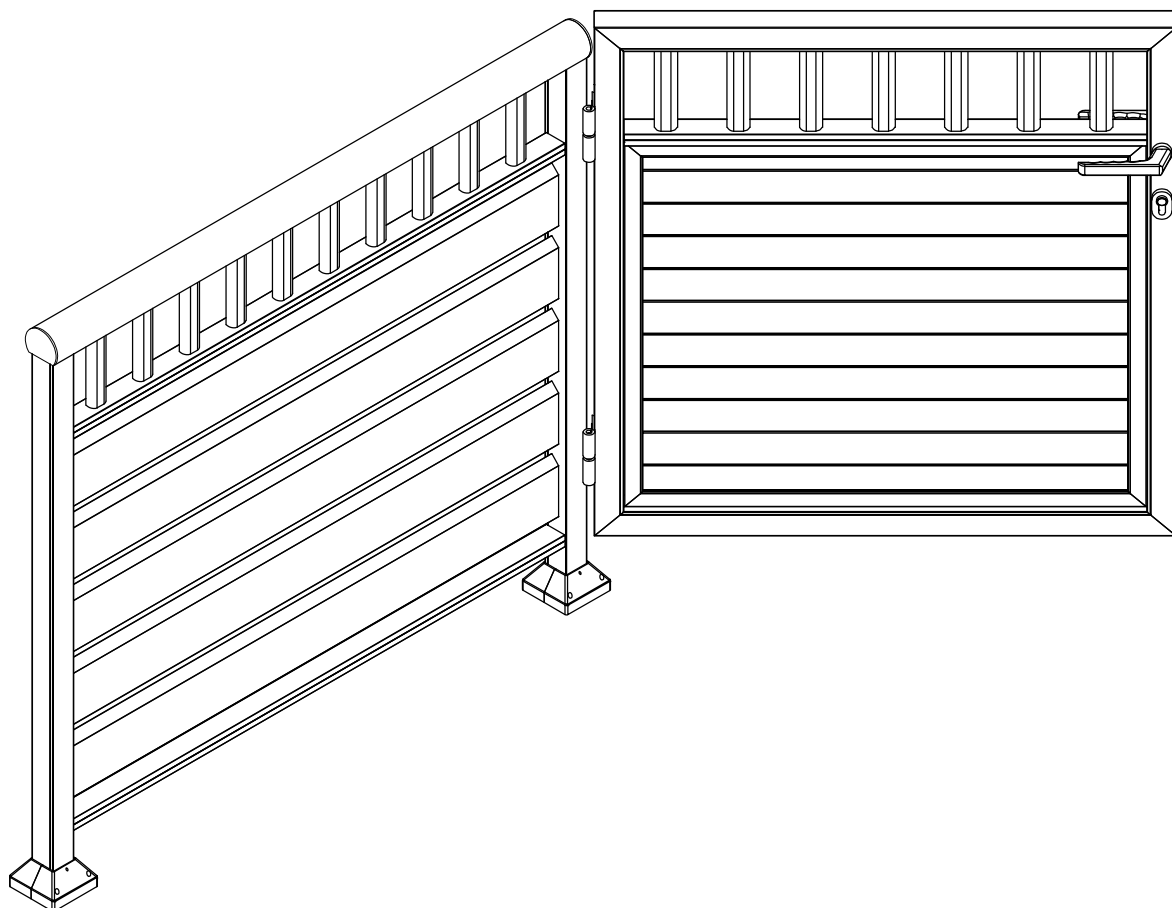
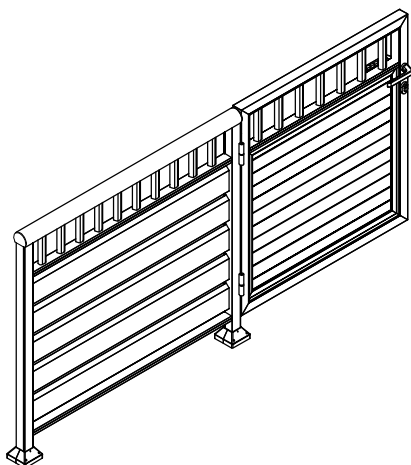

### OF-80 Tip KC-45

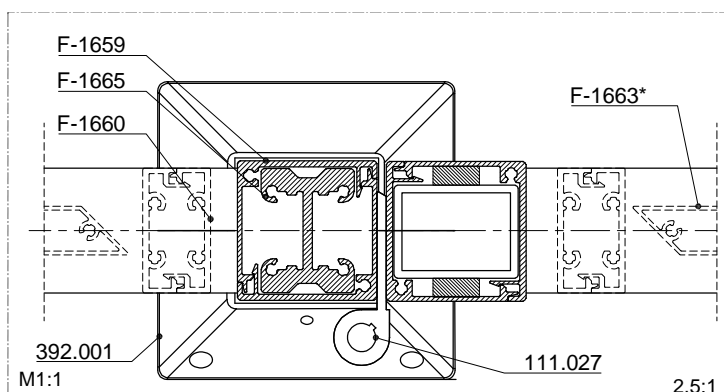
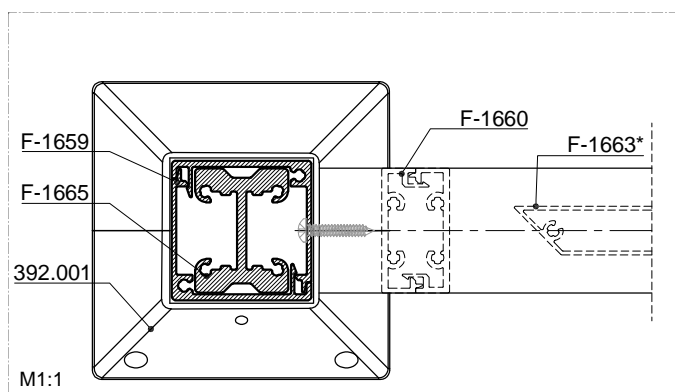
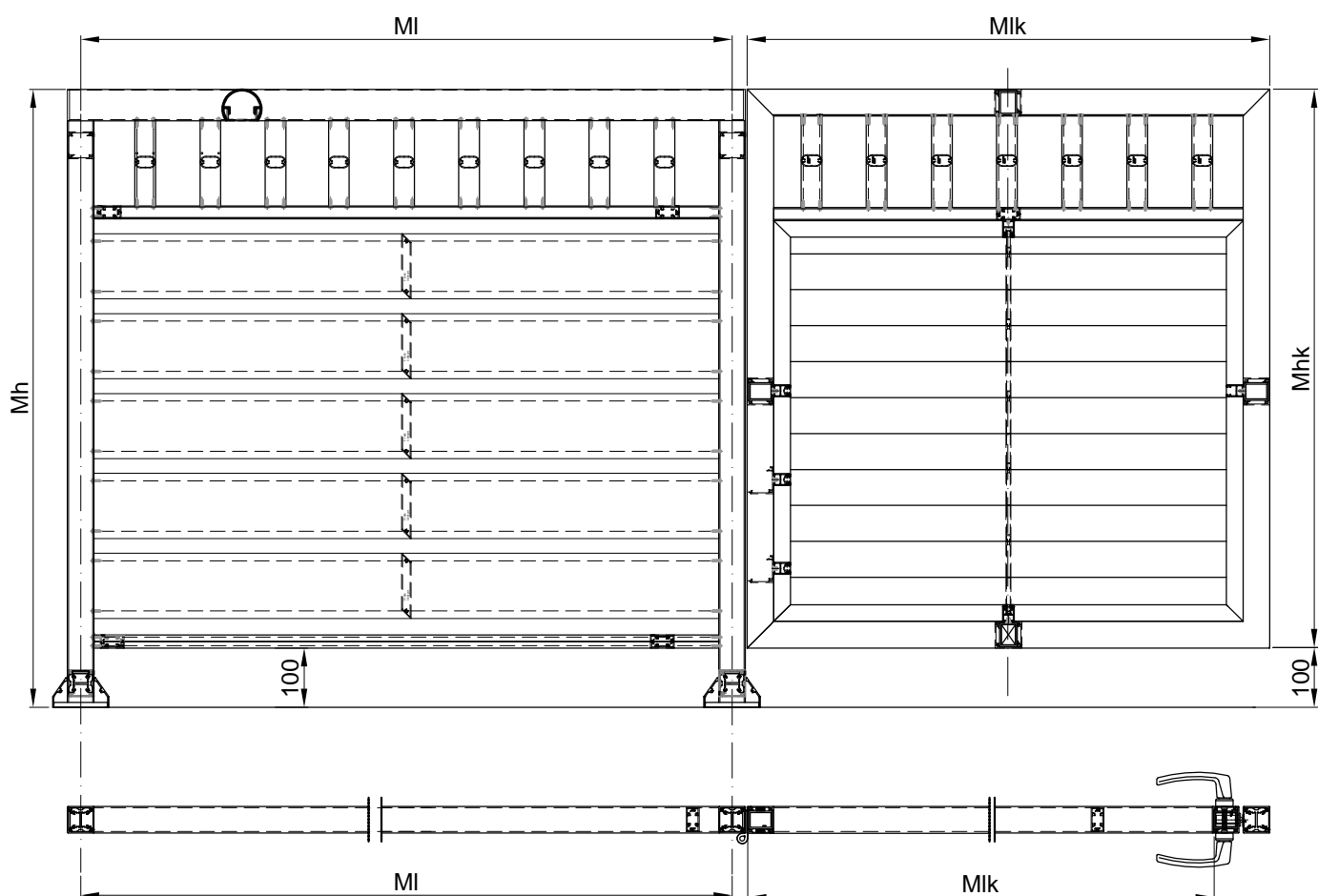
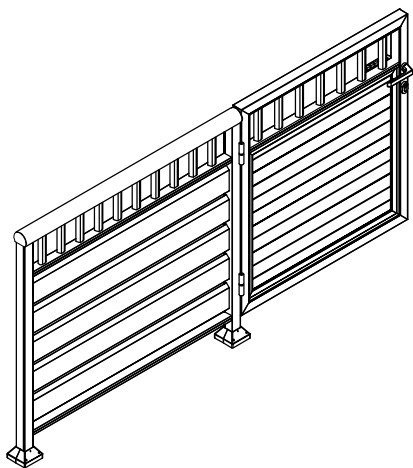

### OF-80 Tip KC-45

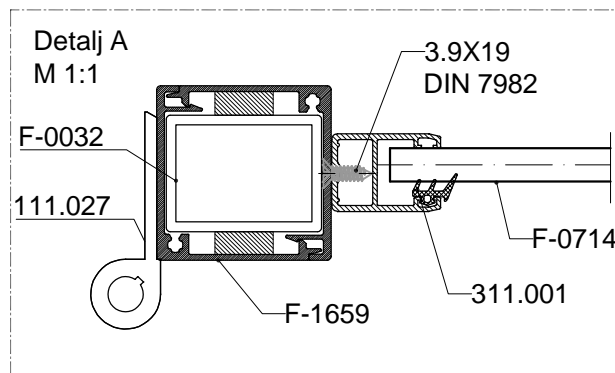
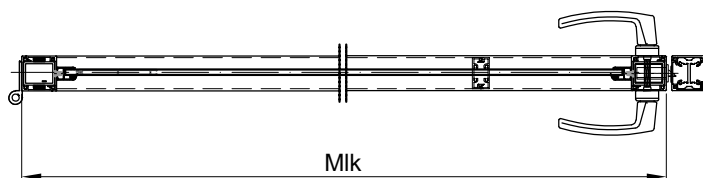
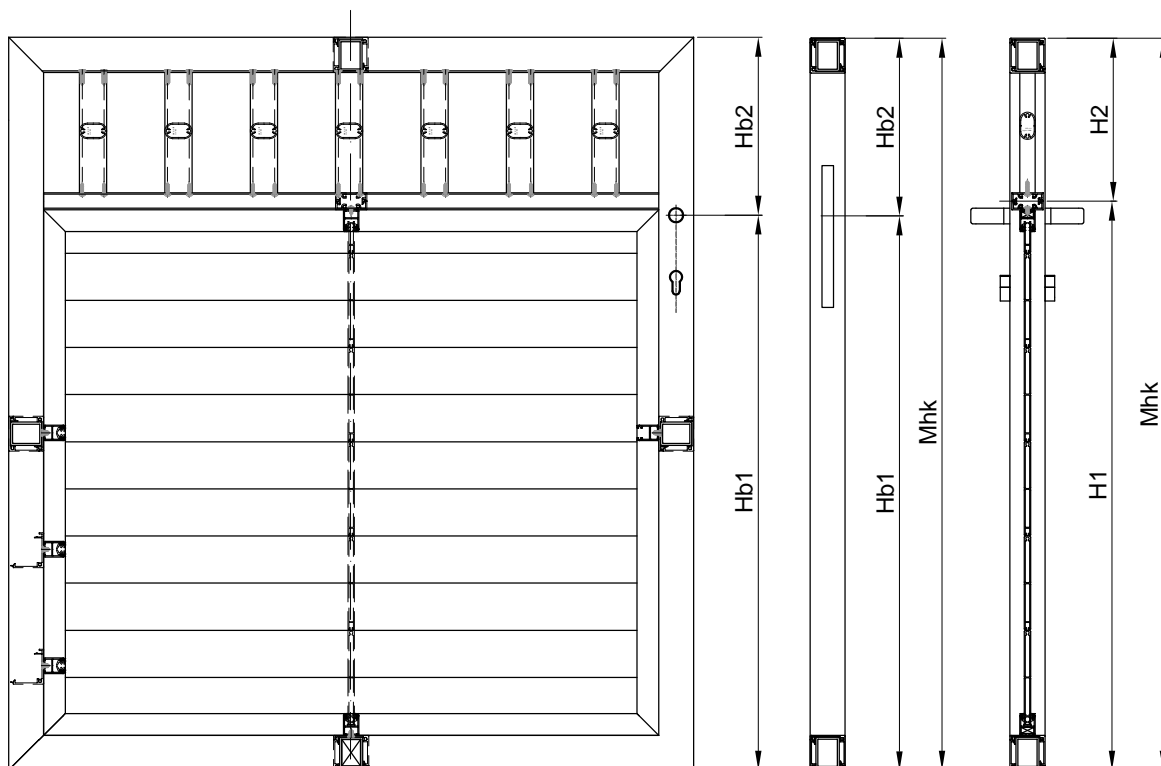
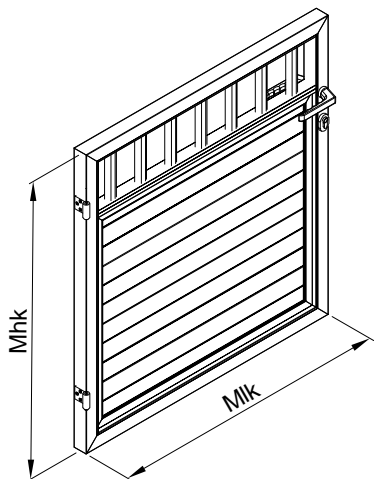

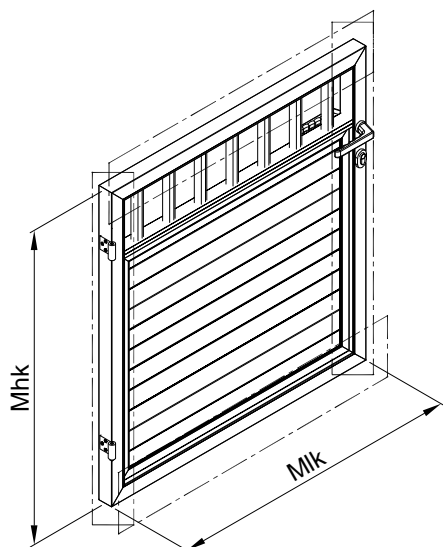

### OF-80 Tip KC-45

npr.: za  $Mlk=1000$  mm i  $Mhk=MH-100=944$  mm

$H1=Mhk-H2=733$  mm

$H2=Mhk-H1=211$  mm

$Hb1=Mhk-Hb2=714$  mm

$Hb2=Mhk-Hb1=230$  mm

#### 1. Postupak pilanja profila F-1659:

- 1.1. Ispilati profile F-1659 pod kutem  $45^\circ$  na mjere  $l=Mhk$  mm prema crtežu
- 1.2. Ispilati profile F-1659 pod kutem  $45^\circ$  na mjere  $l=MLk$  mm prema crtežu

### Unutarnji profili

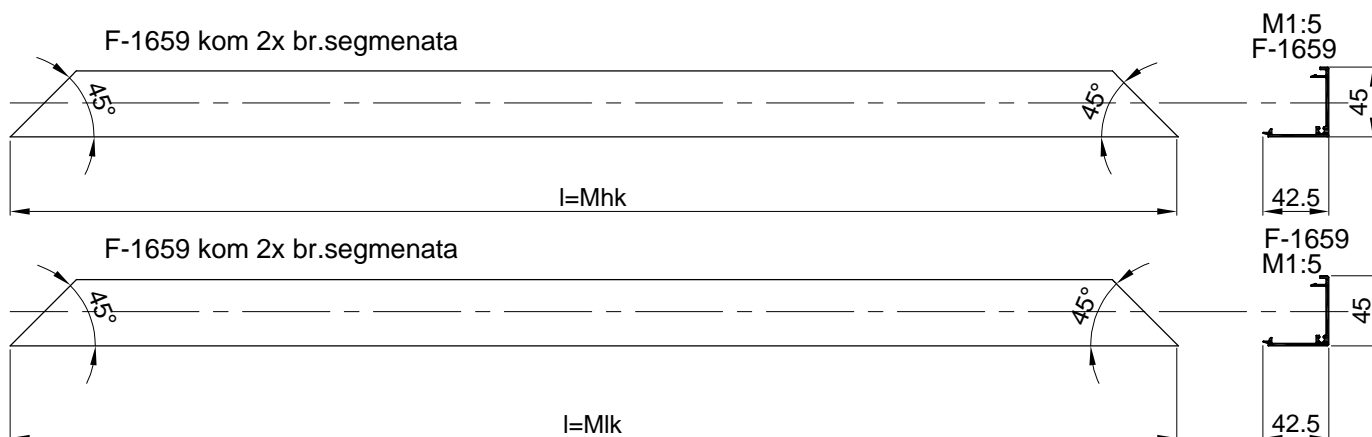

### Vanjski profili

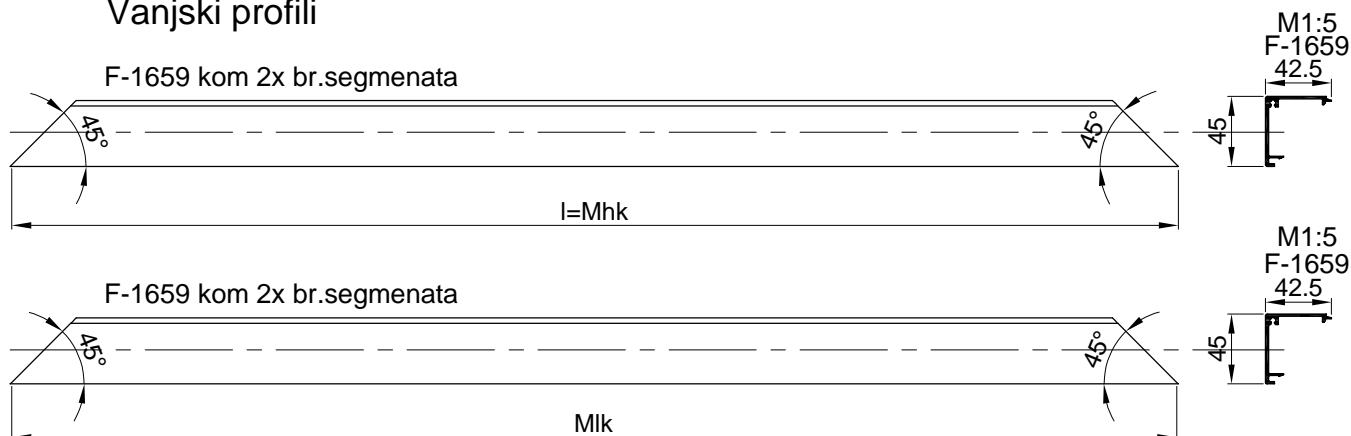

#### Napomena:

Iz jednog podešavanja pile, sve profile F-1659 ispilati na podešenu dužinu.

Ukoliko postoji više segmenata sve profile ispilati iz jednog podešavanja pile prema dimenzijama

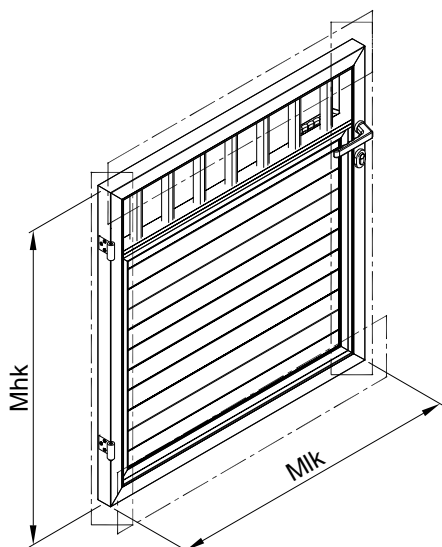

#### 2. Postupak obrade profila F-1664:

- 2.1. Pisanje profila F-1659 na mjere  $l=Mh-61.2$
- 2.2. Pisanje profila F-1664 pod kutem  $45^\circ$  na mjere  $l=Mlk-90$
- 2.3. Pisanje profila F-1664 pod kutem  $45^\circ$  na mjere  $l=H1-56$
- 2.4. Pisanje profila F-0714 na mjere  $l=Mlk-120$

F-1659 kom 2

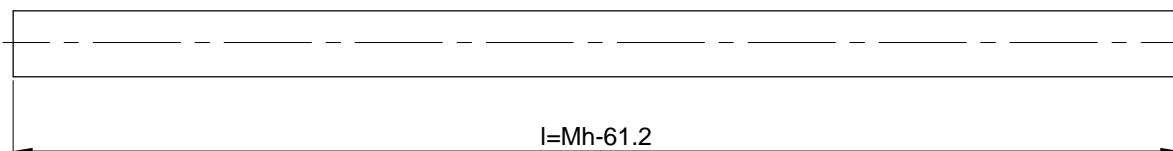

F-1659  
M1:5

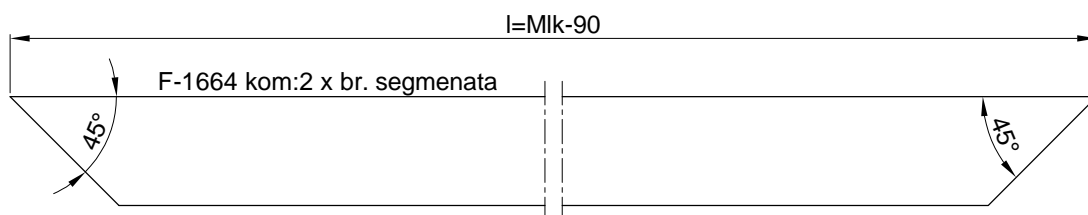
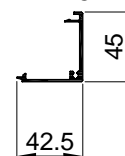

F-1664  
M 1:2

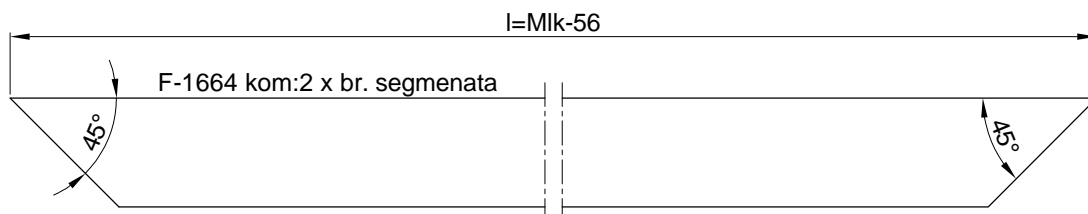
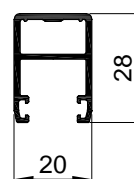

F-1664  
M 1:2

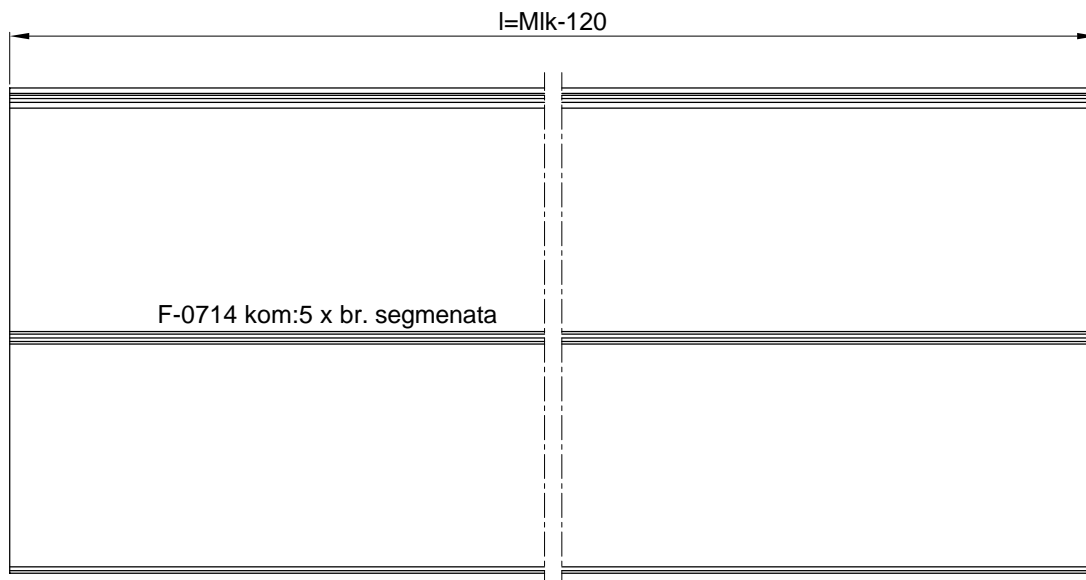
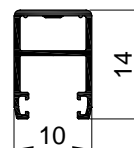

F-0714  
M 1:2

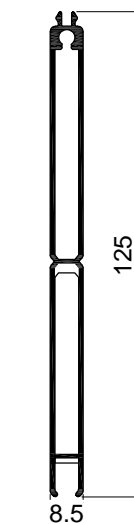

### OF-80 Tip KC-45

#### 3. Postupak obrade profila F-0714:

- 3.1. Pisanje profila F-1660 na mjere  $l=Mik-90$
- 3.2. Pisanje profila F-0032 na mjere  $l=Mik-5$
- 3.3. Pisanje profila F-0032 na mjere  $l=Mhk-5$
- 3.4. Pisanje profila OG-111 na mjere  $l=H2-56$

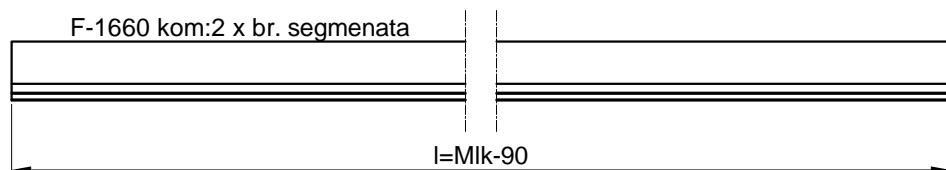
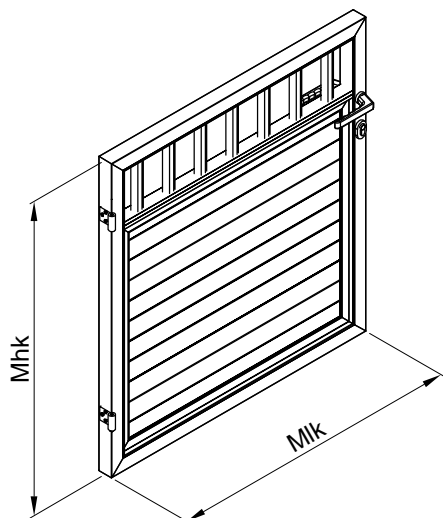

F-1667  
M 1:2

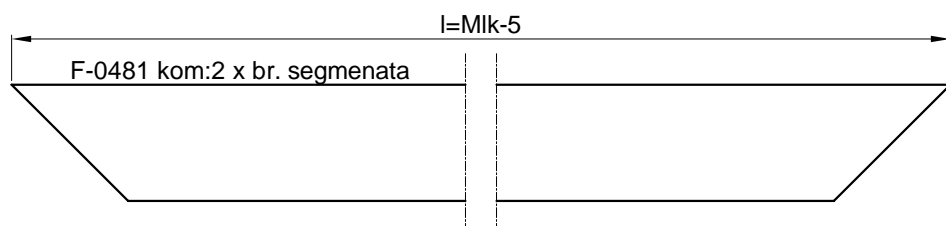
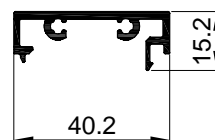

F-0032  
M 1:2

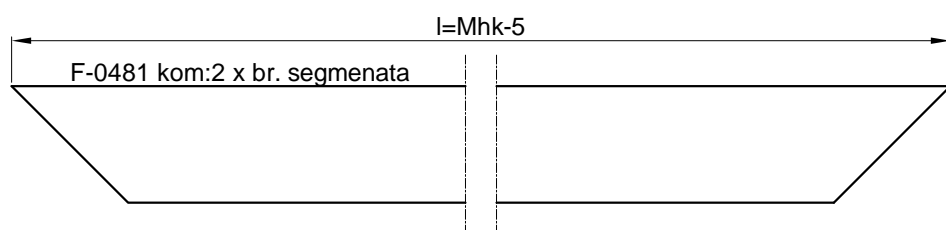
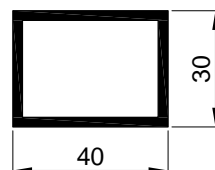

F-0481  
M 1:2

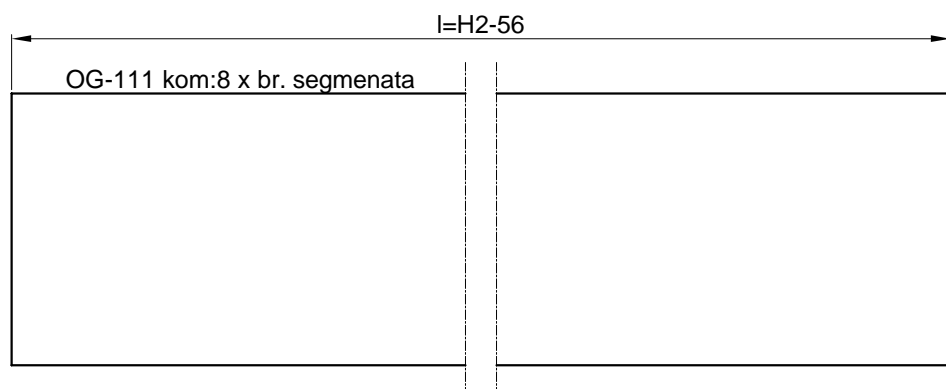
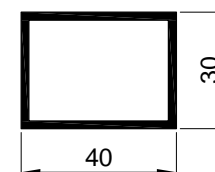

OG-111  
M 1:1

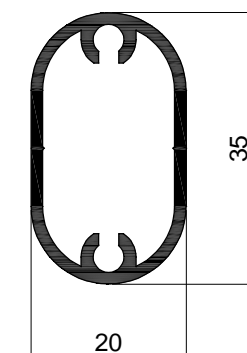

### OF-80 Tip KC-45

#### 4. Postupak obrade profila F-1664:

##### 4.1. Obraditi profile F-1664 za kutne spojnice 725.213 prema crtežu

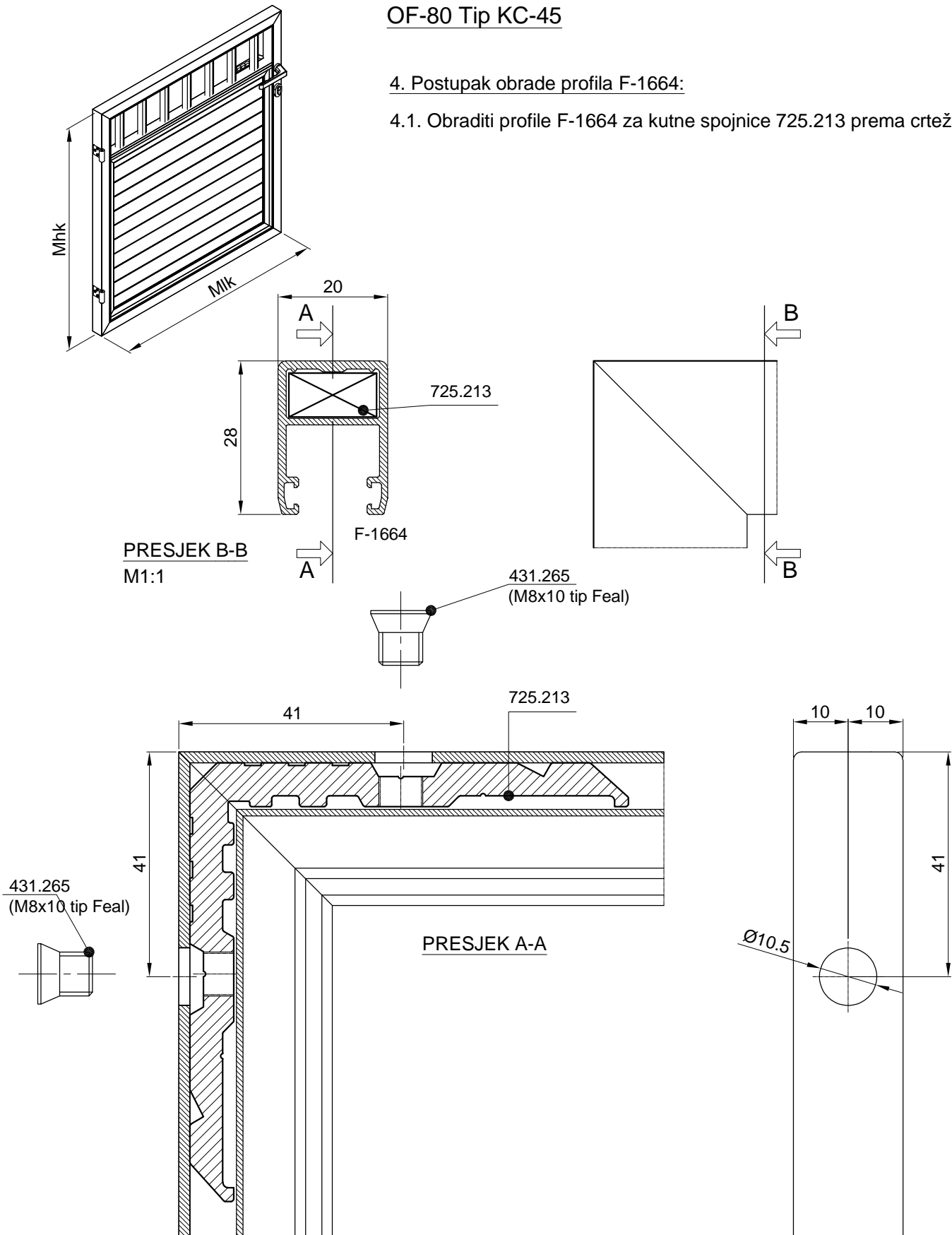

725.213 (F-1628)

NAPOMENA: SPAJANJE PROFILA KUTNIM  
SPOJNICAMA (vijčana veza)

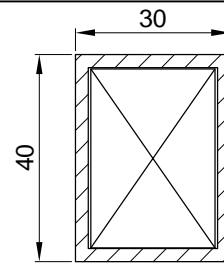

Obrada profila  
F-0032 za kutnu  
spojnicu 710.073

M1:1

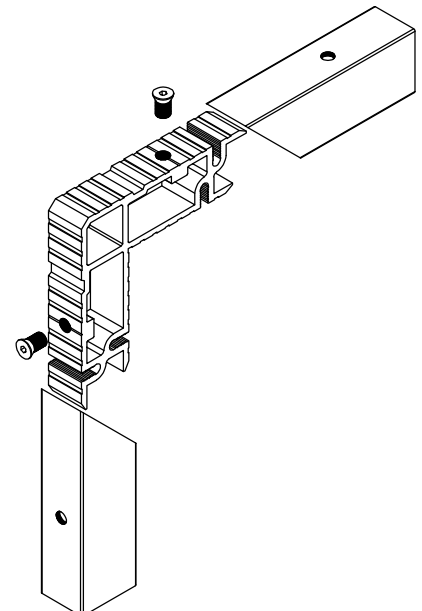
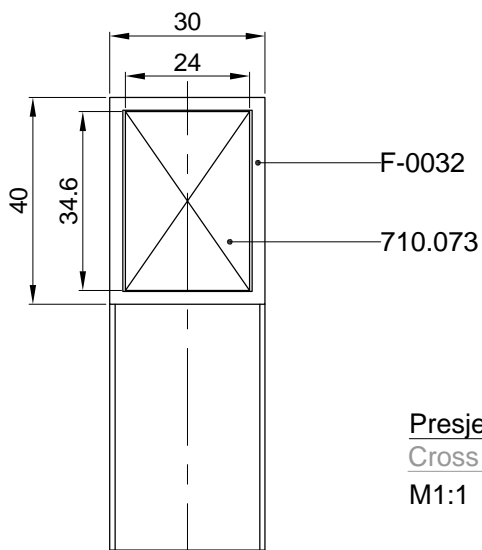
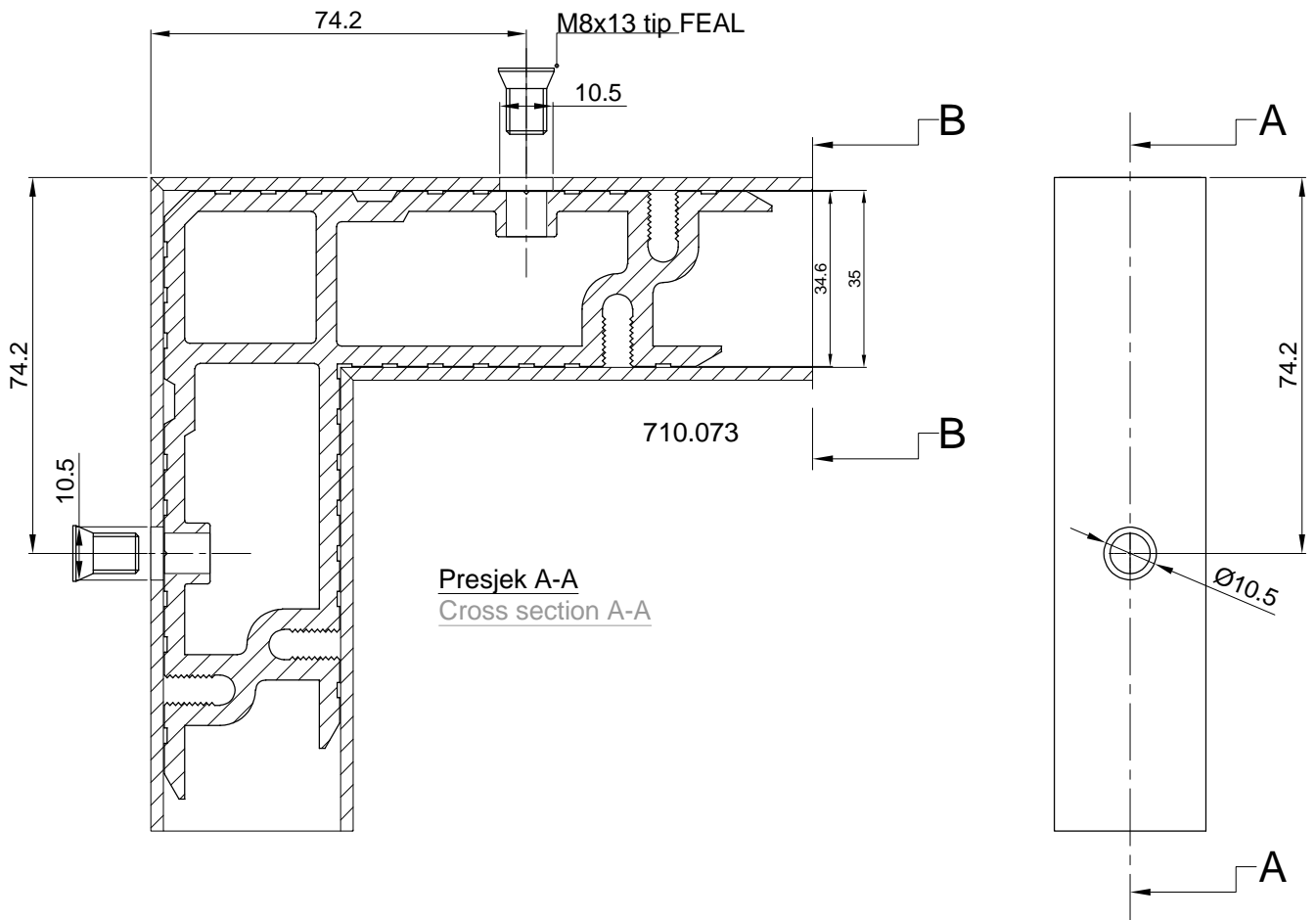

#### OF-80 Tip KC-45

#### 4. Postupak obrade profila F-1659 :

4.1. Izbušiti rupe  $\varnothing 5$  na vanjskom profilu F-1659 za prihvat baglame prema crtežu

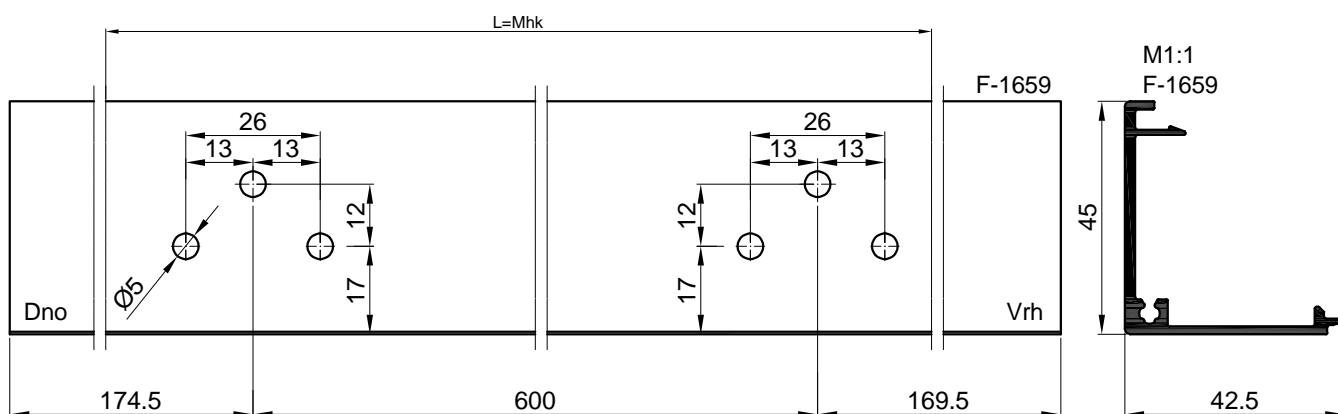
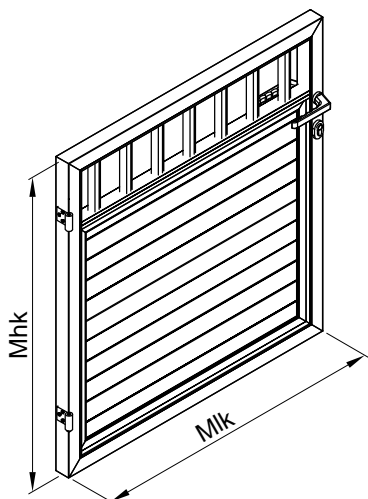

**NAPOMENA:**

Može se koristiti baglama kao šablon na plaštu i moždaniku



### OF-80 Tip KC-45

#### 6. Postupak obrade profila F-1659

- 6.1. Obraditi vanjske profile F-1659 za prihvat ručke prema crtežu
- 6.2. Izbušiti rupe  $\varnothing 4$  na unutarnje vertikalne profile F-1659 prema crtežu

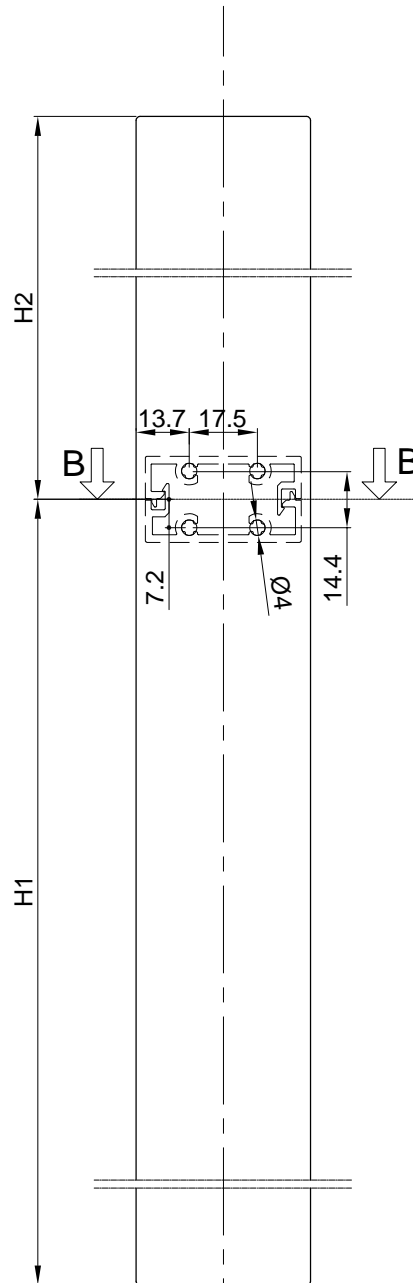
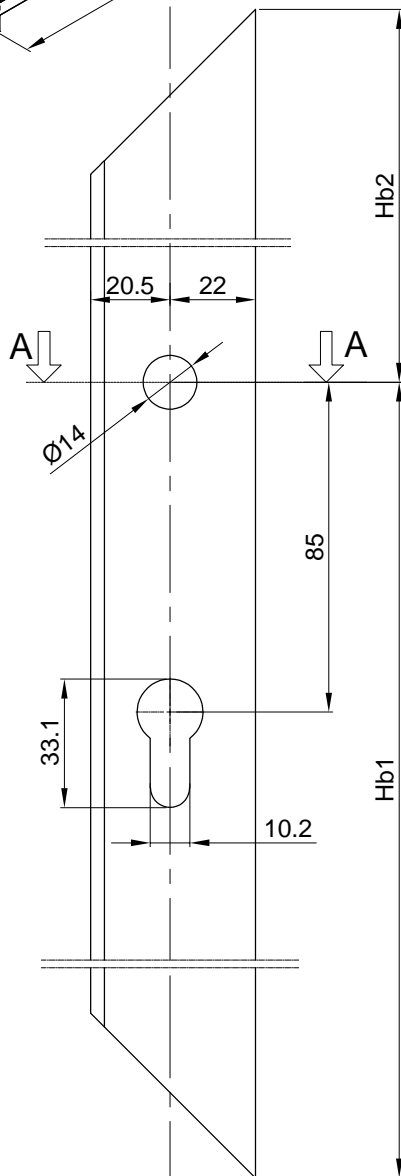
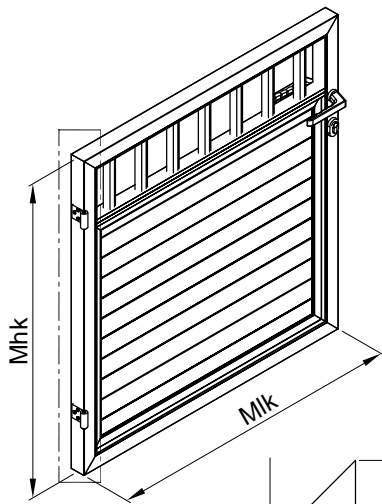

Vanjski profil  
F-1659

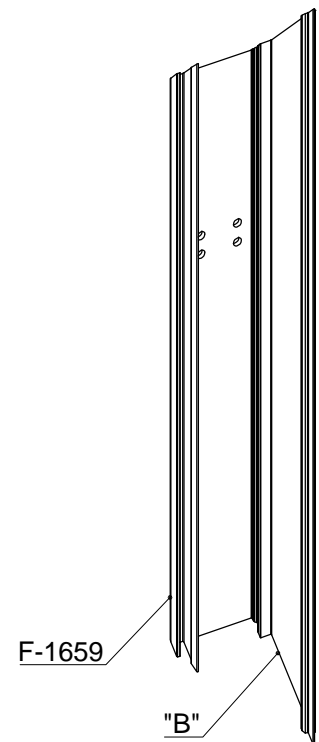
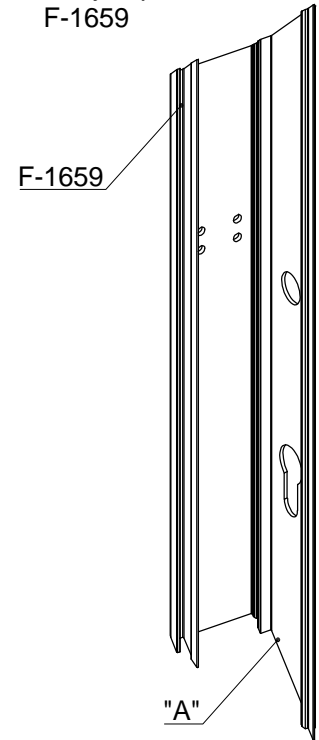

Presjek A-A  
M 1:2  
F-1659

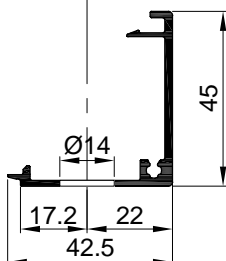

Presjek B-B  
M 1:2  
F-1659

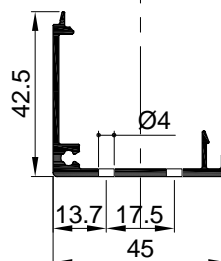

### OF-80 Tip KC-45

#### 7. Postupak obrade profila F-0032

7.1. Obraditi vertikalni moždanik F-0032 za prihvat brave i ručke prema crtežu

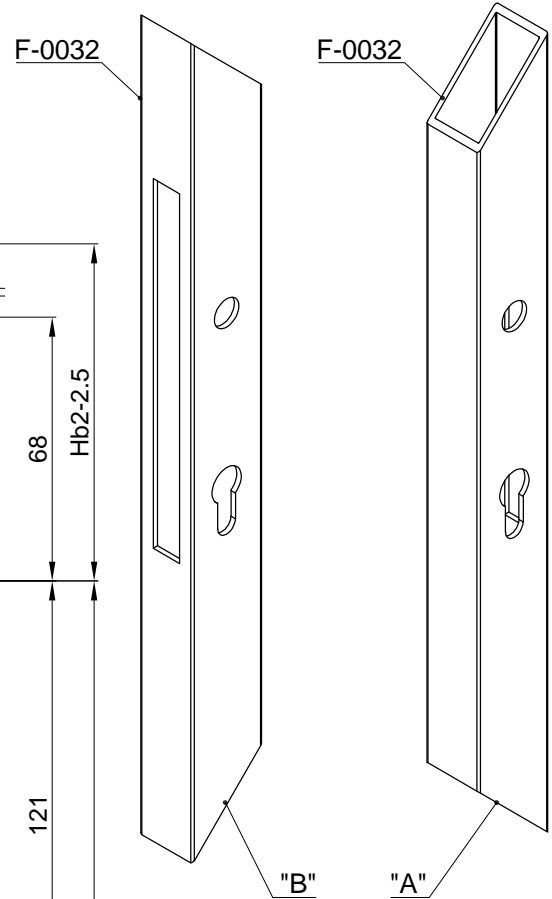
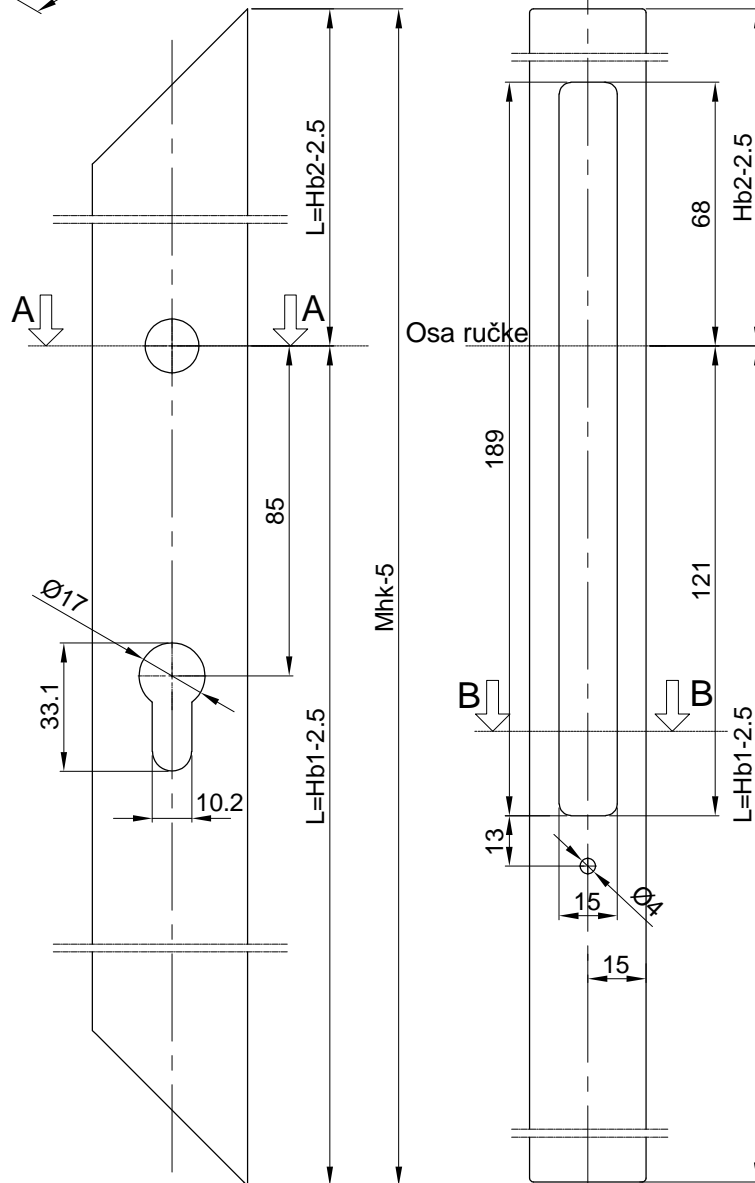
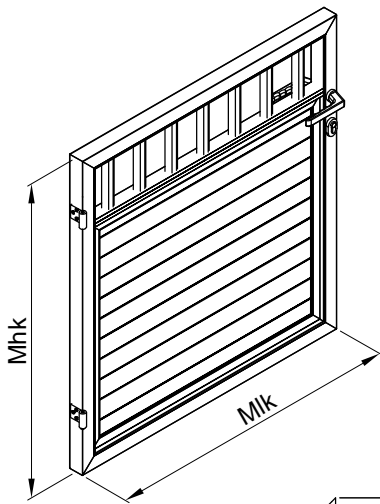

Presjek A-A  
M 1:2  
F-0032

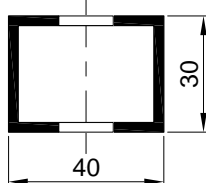

Presjek B-B  
M 1:2  
F-0032

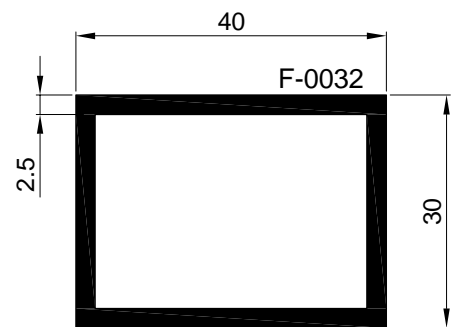
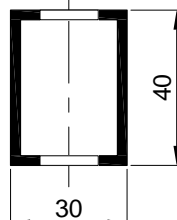

M 1:1

#### OF-80 Tip KC-45

#### 8. Postupak obrade profila F-1659

##### 8.1. Obraditi vanjske profile F-1659 za prihvat brave prema crtežu

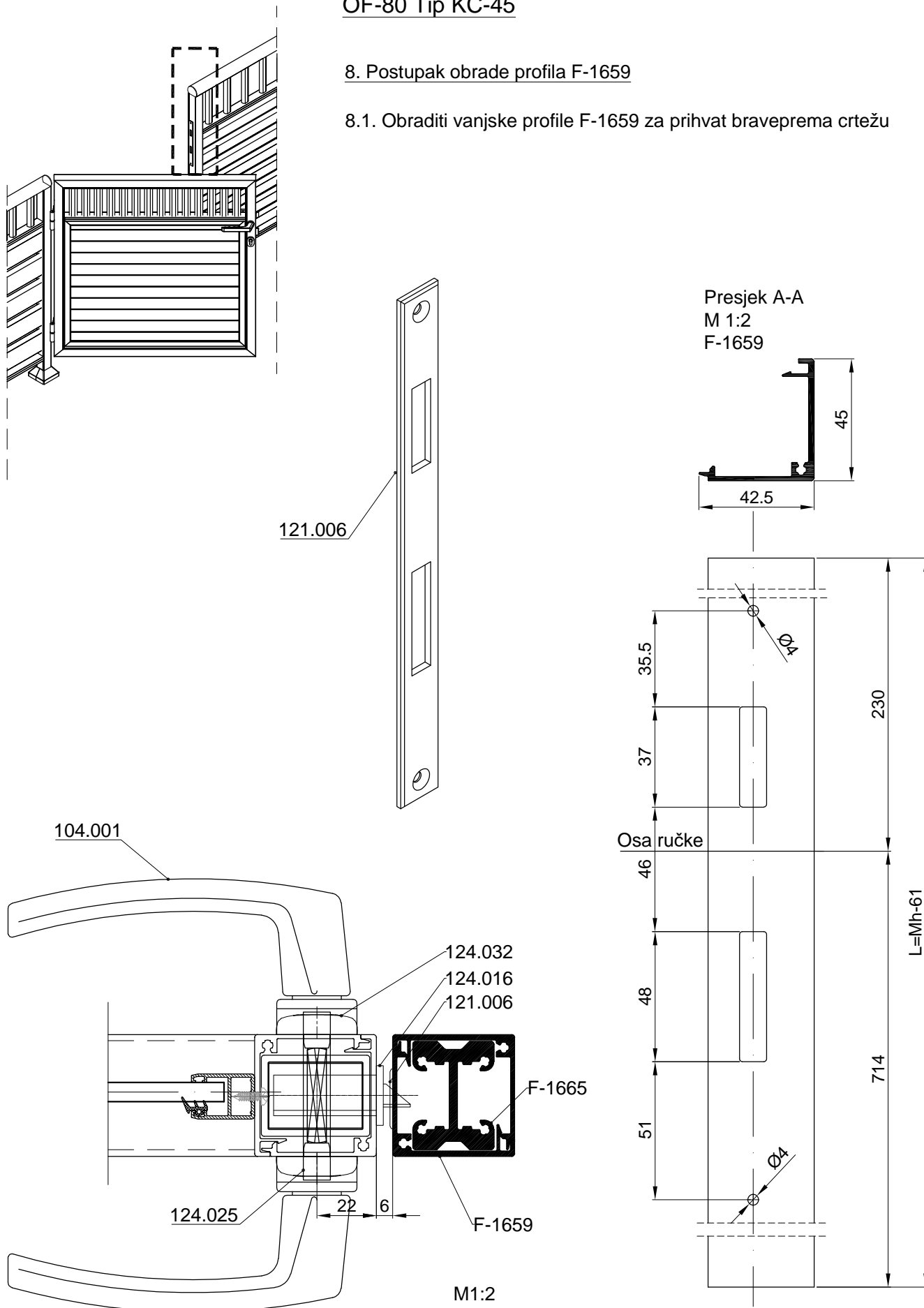

### OF-80 Tip KC-45

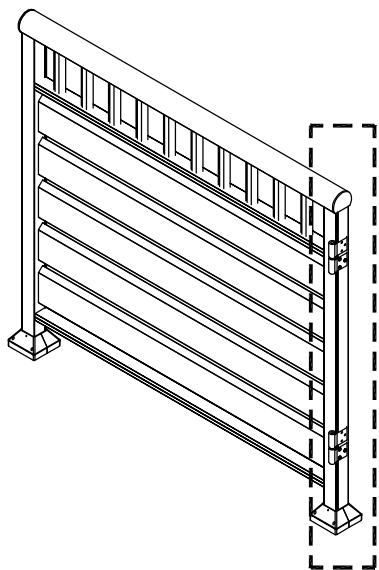

#### 9. Postupak obrade profila F-1659

9.1. Izbušiti rupe Ø5 na vanjskom profilu F-1659 za prihvat baglame prema crtežu

**NAPOMENA:**  
Može se koristiti baglama kao šablon na plaštu i moždaniku

Presjek A-A  
M 1:2  
F-1659

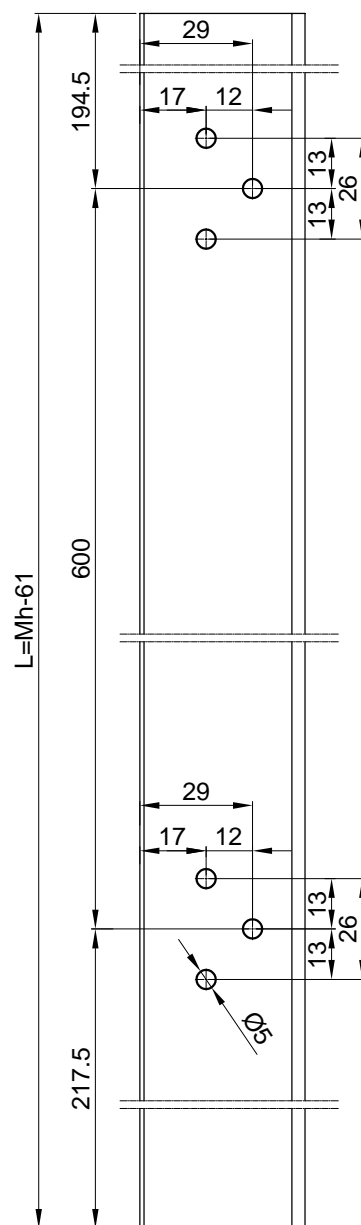
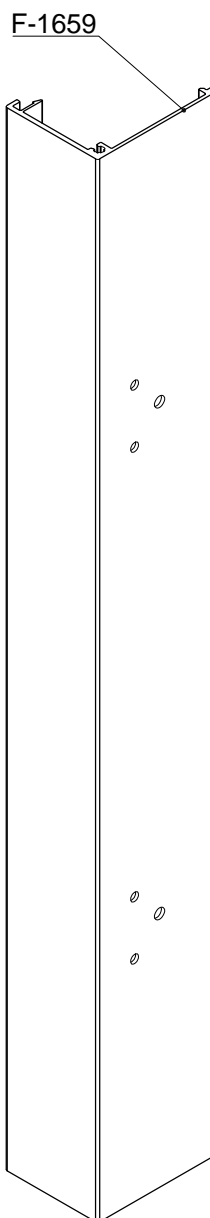
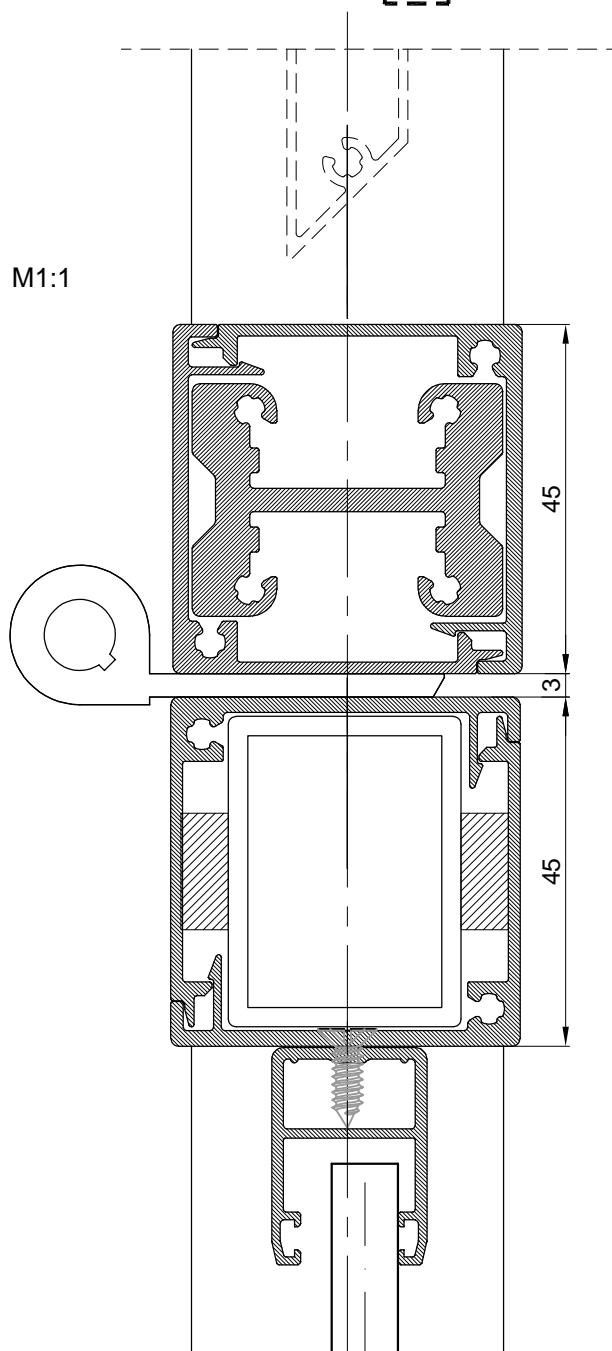
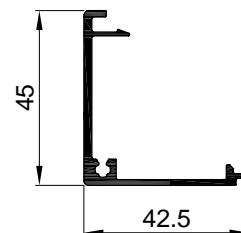

### OF-80 Tip KC-86

#### 10. Postupak montaže okvira profila F-1664:

- 10.1. Umetnuti brtve 321.002 u profile F-1664
- 10.2. Napraviti ram od profila F-1664 prema shemi

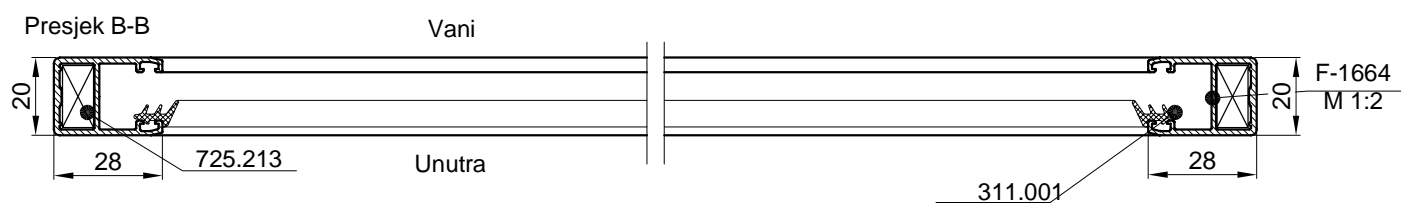
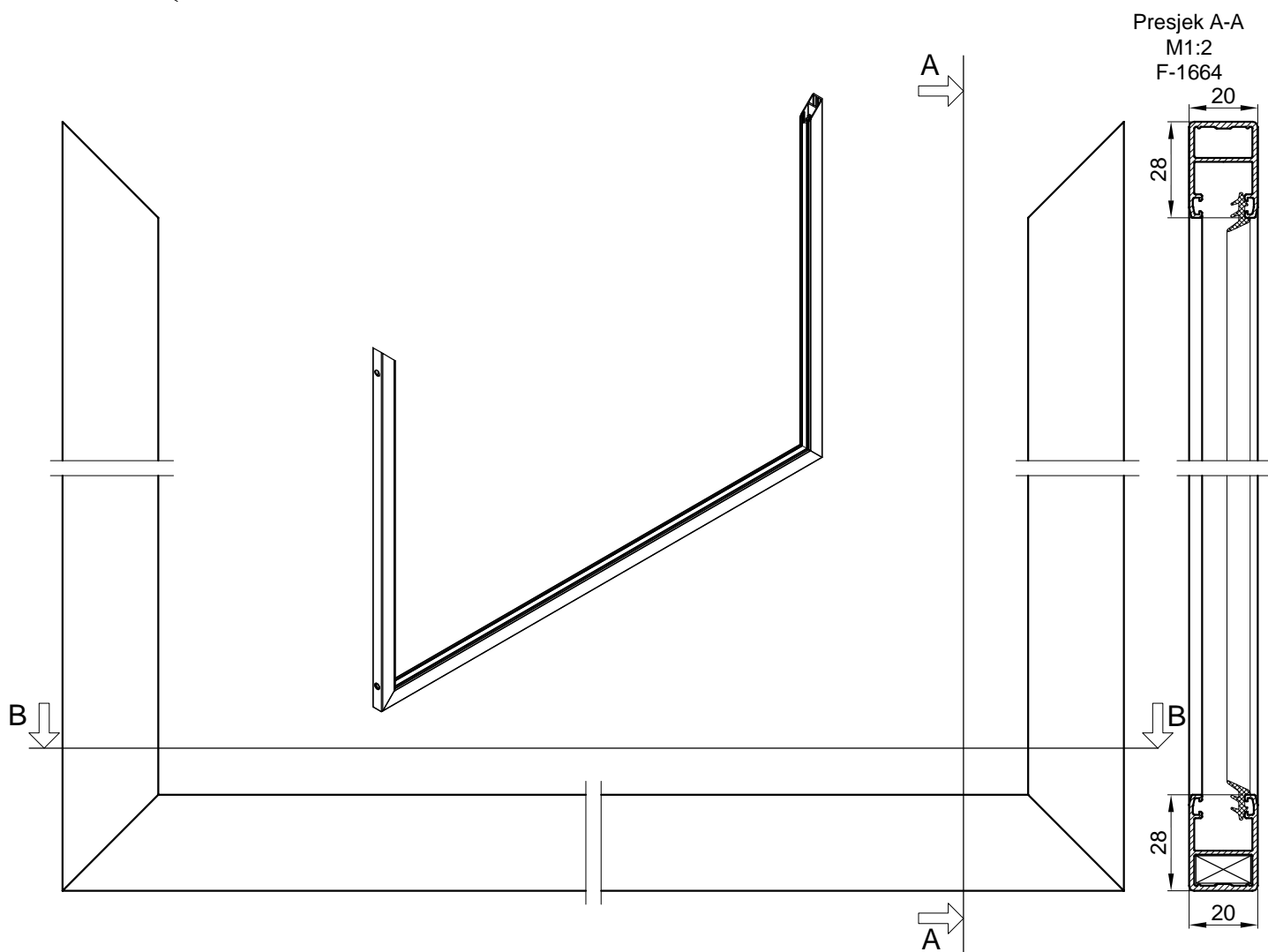
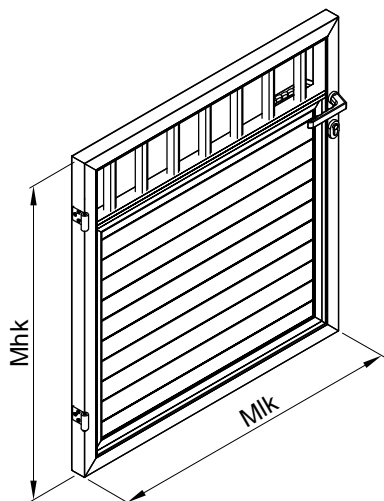

### OF-80 Tip KC-86

#### 11. Postupak umetanja ispune profila F-0714:

11.1. Umetnuti profile ispune F-0714 u okvir od profila F-1664 prema shemi

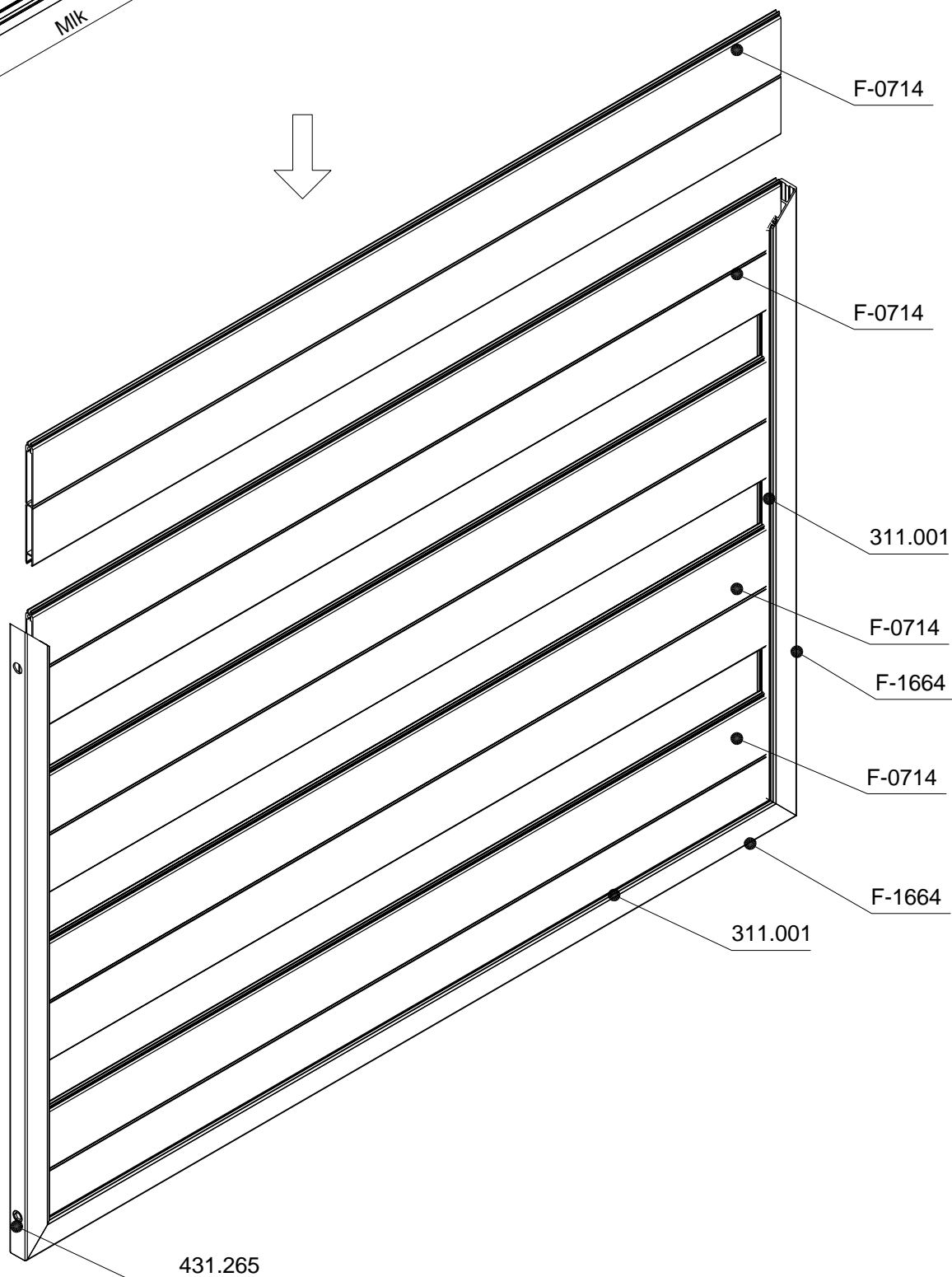
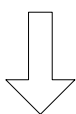
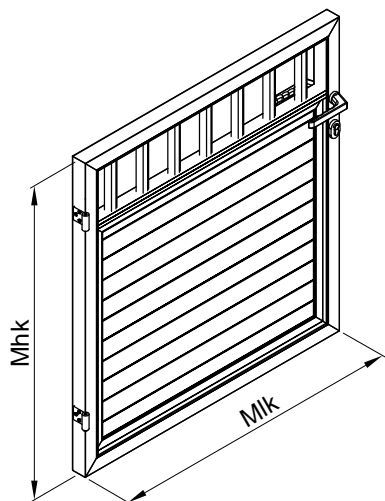

### OF-80 Tip KC-86

#### 12. Postupak završetka spajanja rama profila F-1664:

12.1. Spojiti gornji horizontalni pojas rama s donjim dijelom rama prema shemi

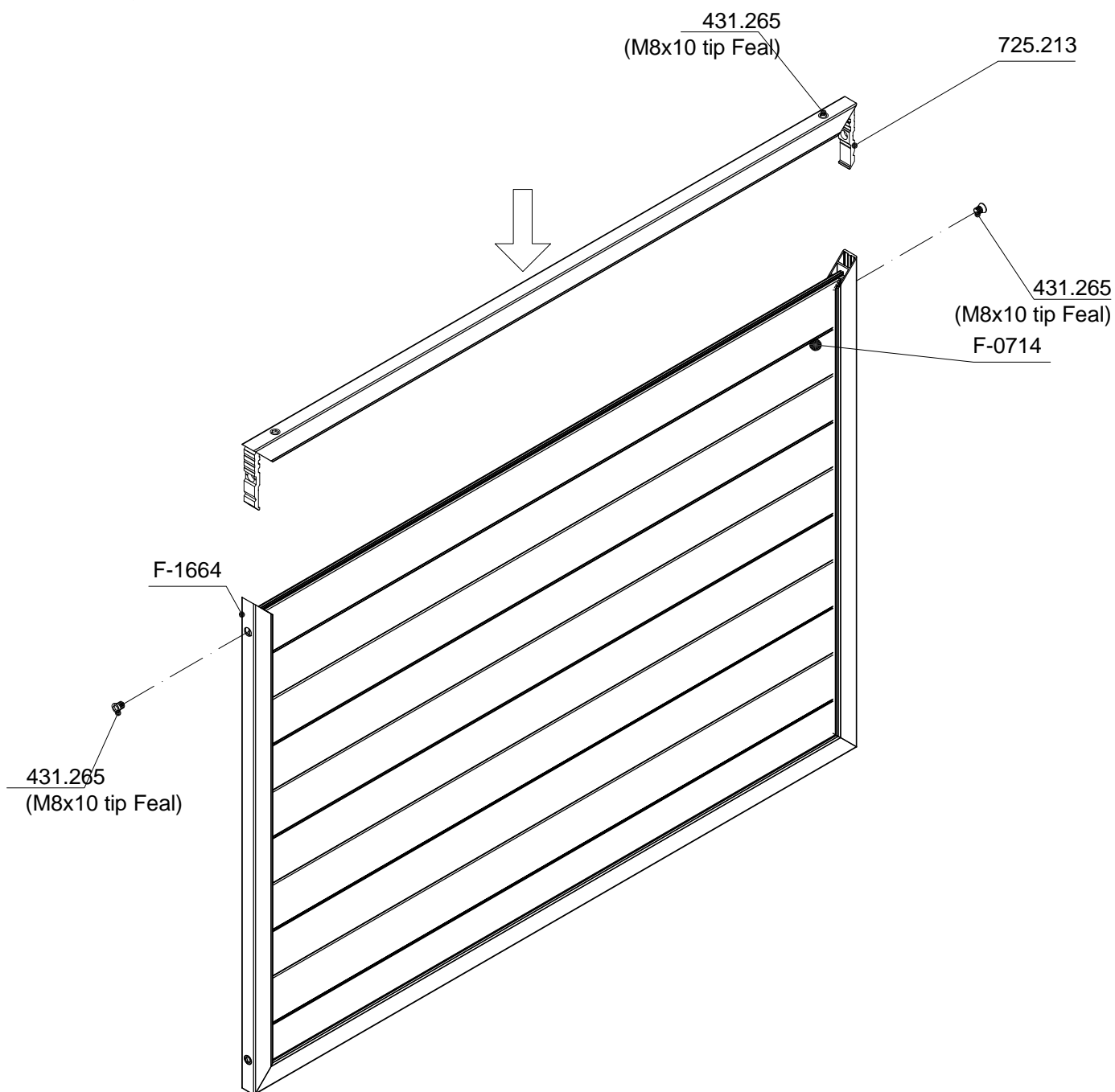
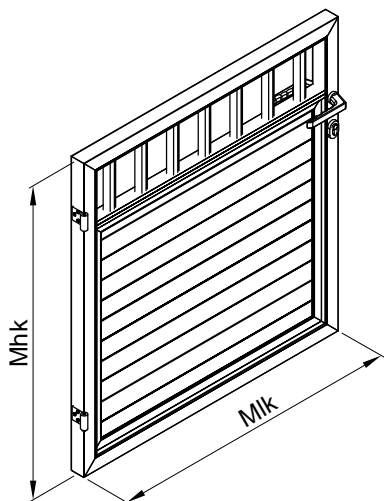

### OF-80 Tip KC-45

#### 13. Postupak montaže profila F-1659:

13.1. Unutarnji plašt kapije profili F-1659 vežemo za ispunu F-1664 pomoću vijaka 433.106 (3.9x13 DIN 7982) prema shemi

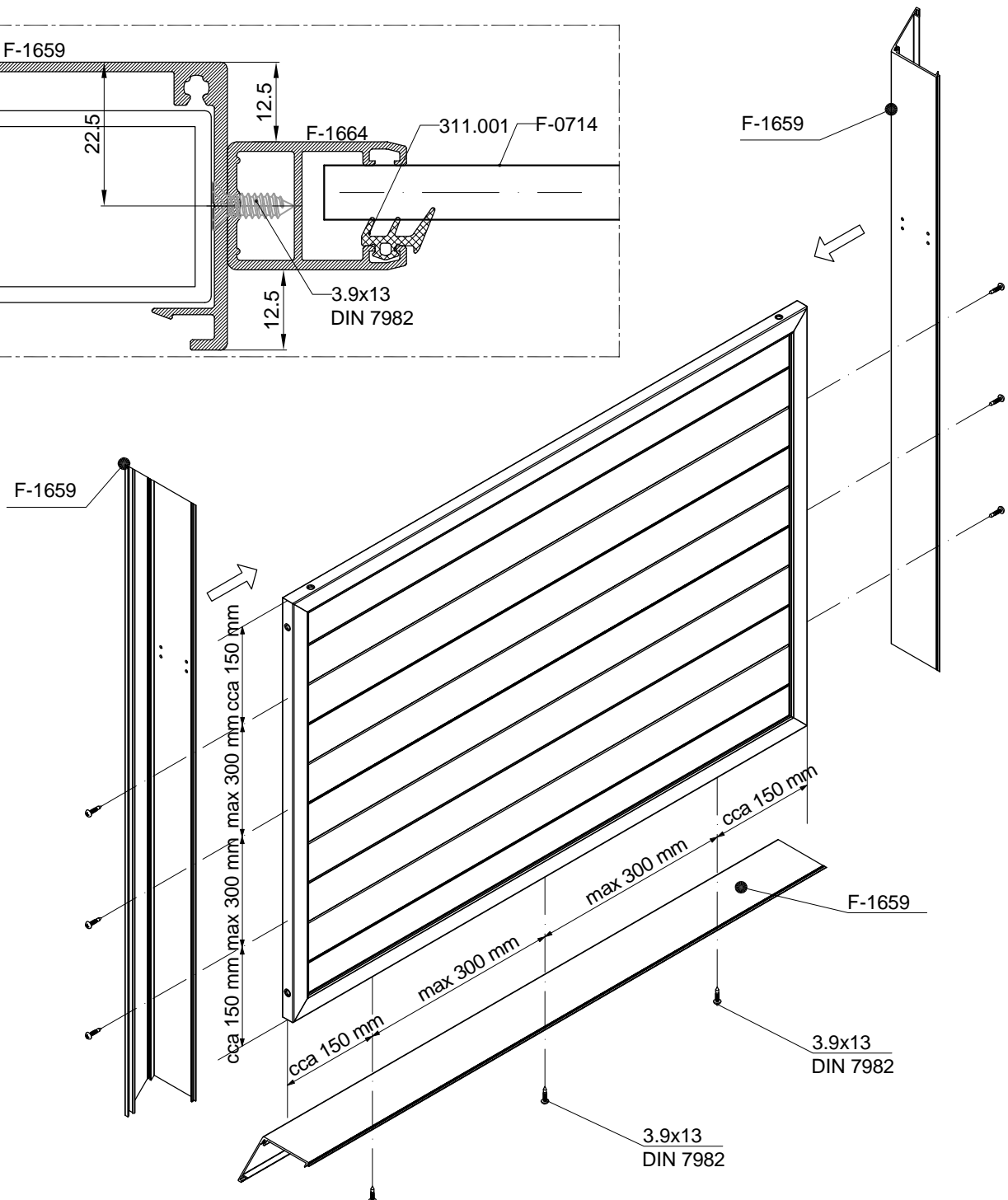
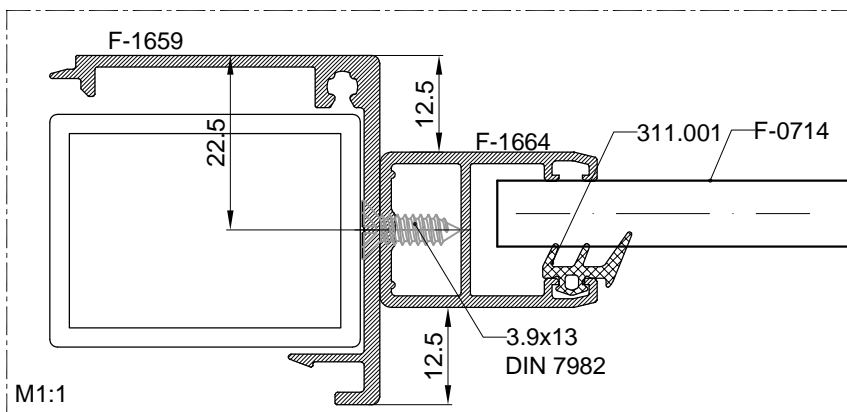
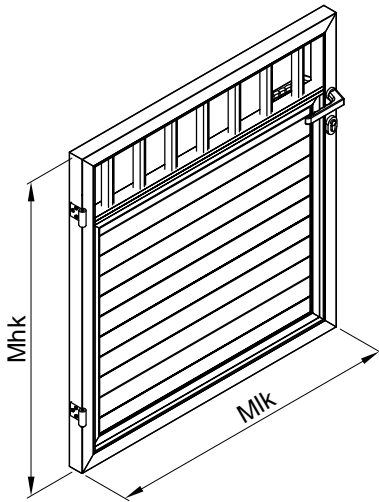

## OF-80 Tip KC-45

14. Postupak spajanja gornjeg dijela segmenta kapije s donjim dijelom segmenta kapije:

14.1. Umetanje gornjeg dijela kapije u okvir prema shemi

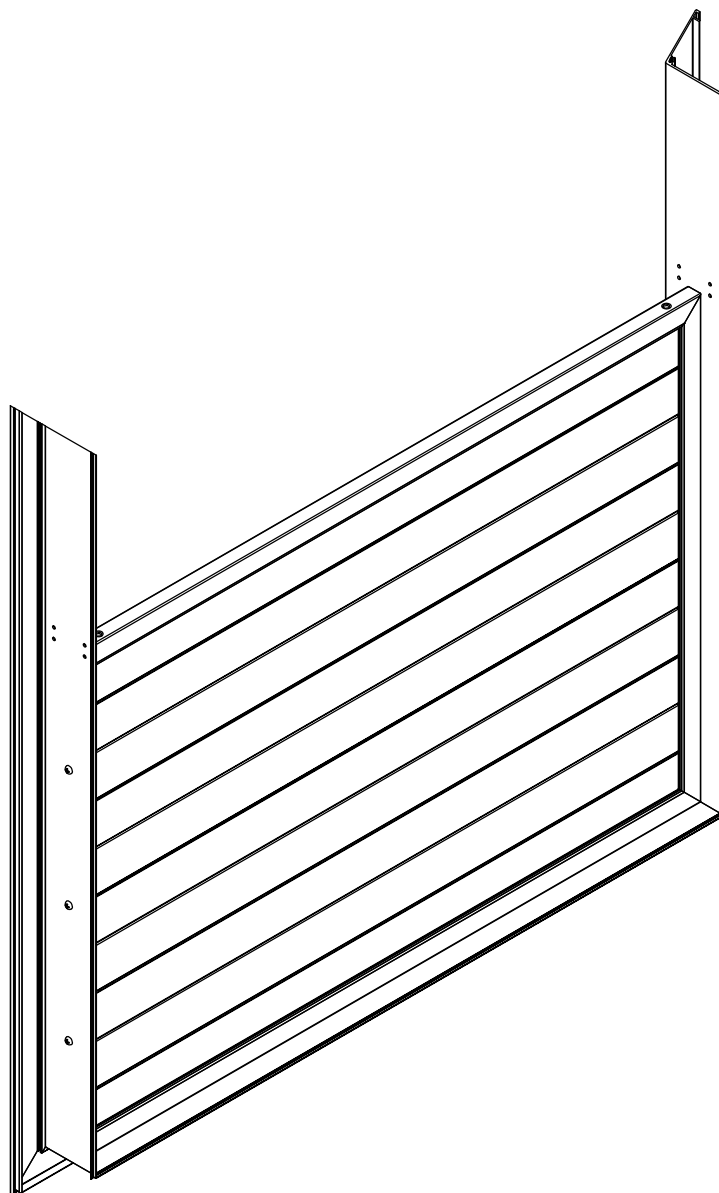
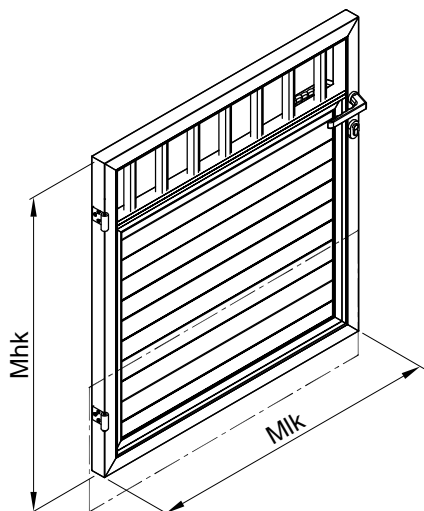

### OF-80 Tip KC-45

#### 15. Postupak montaže profila F-1659:

15.1. Unutarnji plašt kapije profili F-1666 vežemo za ispunu F-1664 pomoću vijaka 433.106 (3.9x13 DIN 7982) prema shemi

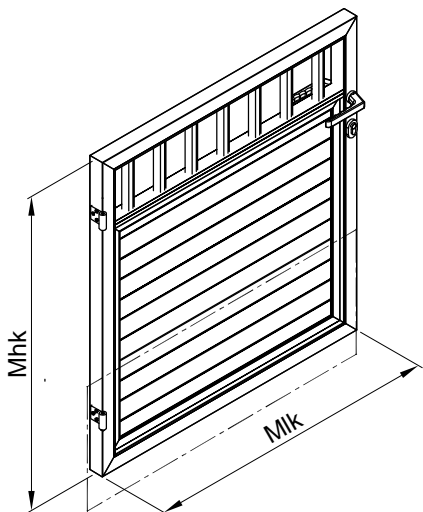

Presjek A-A  
M1:2  
F-1660

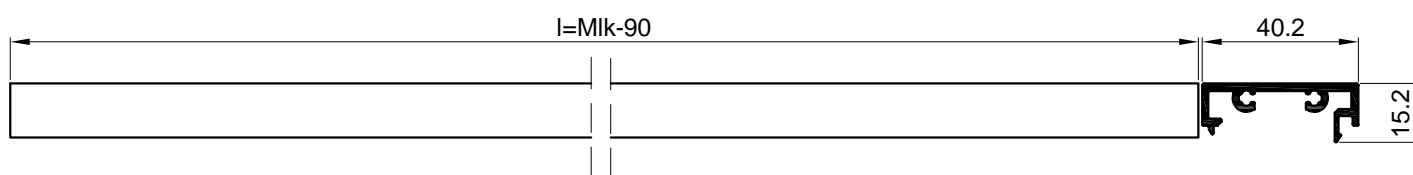

Presjek A-A  
M1:2  
F-1660

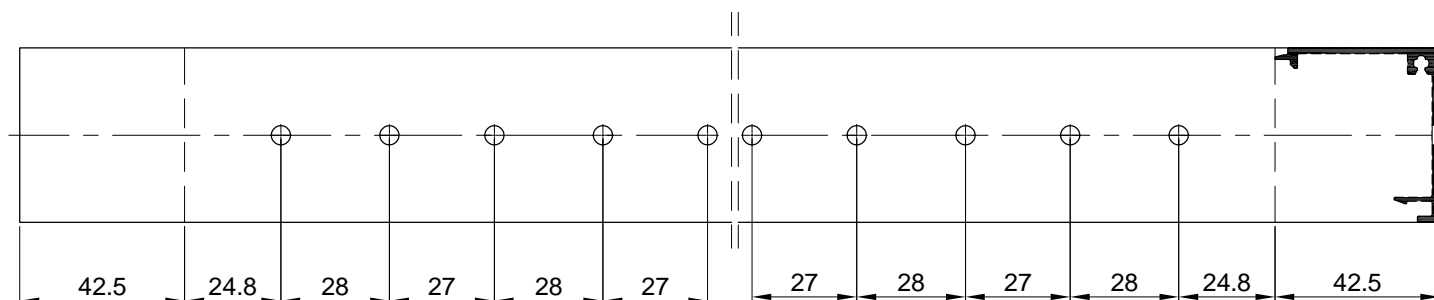
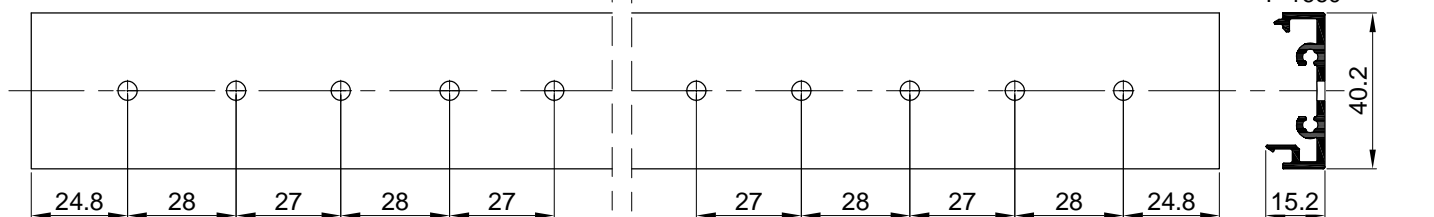

Presjek A-A  
M1:2  
F-1659

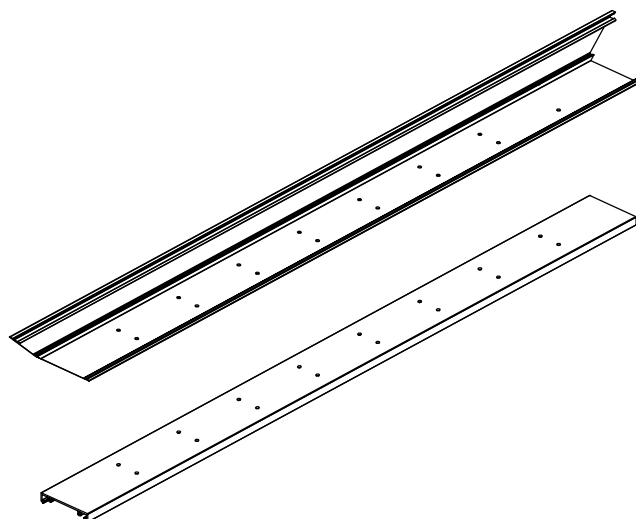

### OF-80 Tip KC-45

#### 16. Postupak spajanja profila F-1659, F-1660 i OG-111:

##### 16.1. Montaža profila OG-111 između profila F-1659 i F-1660 prema shemi

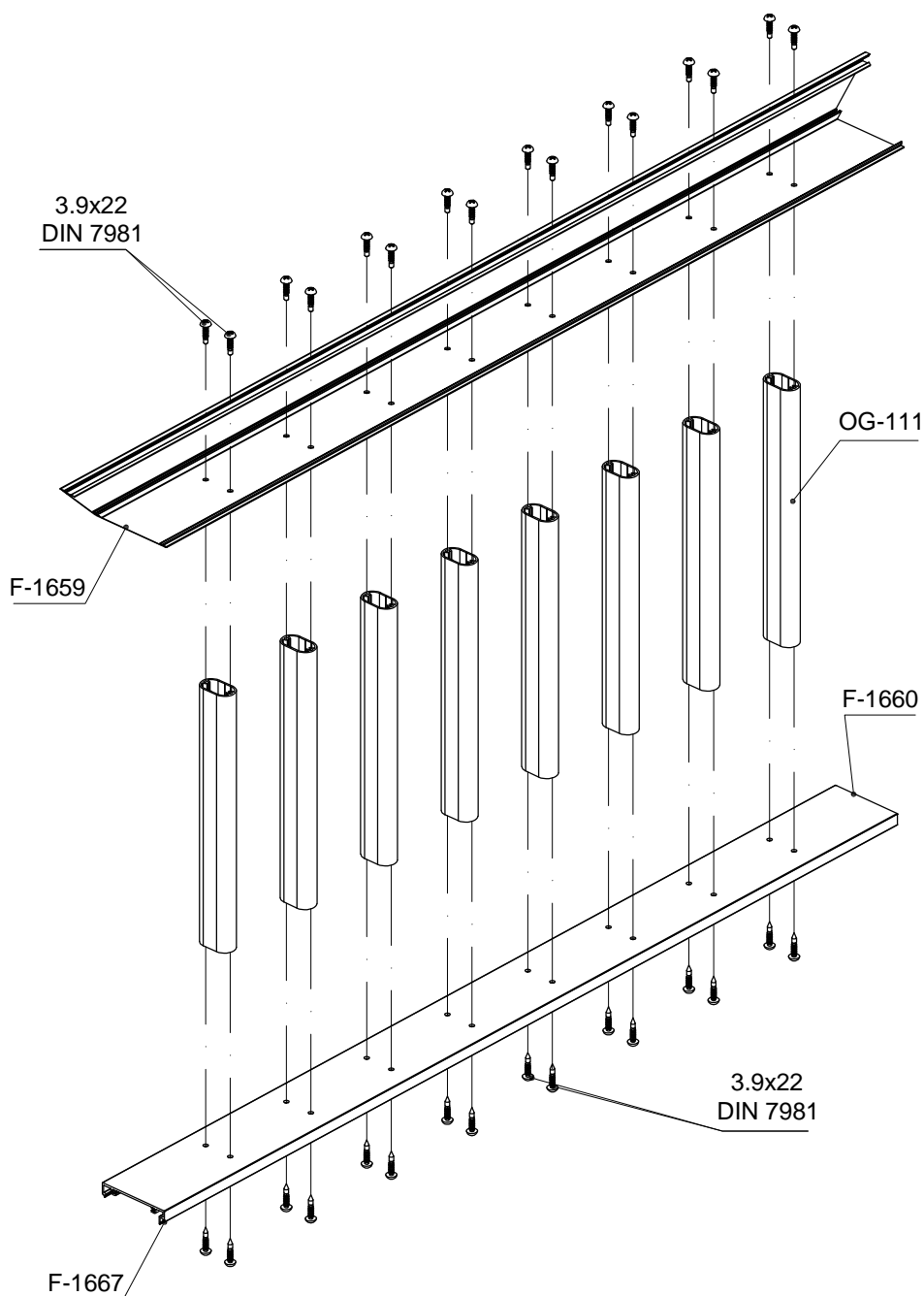
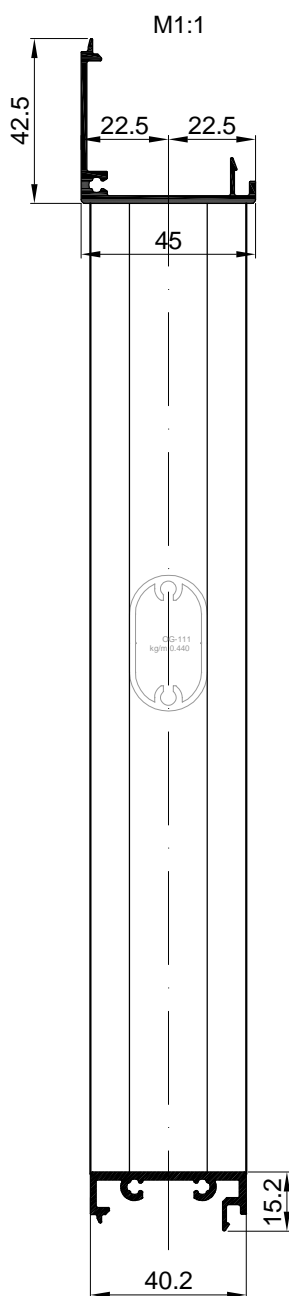
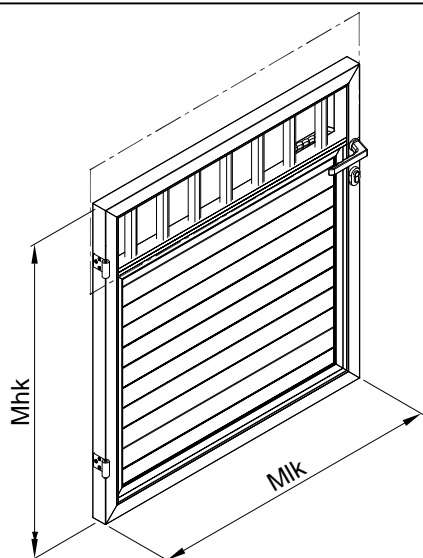

#### OF-80 Tip KC-45

17. Postupak spajanja gornjeg dijela segmenta kapije s donjim dijelom segmenta kapije:

17.1. Umetanje gornjeg dijela kapije u okvir i spajanje vijcima (3.9x22 DIN 7982) prema shemi.

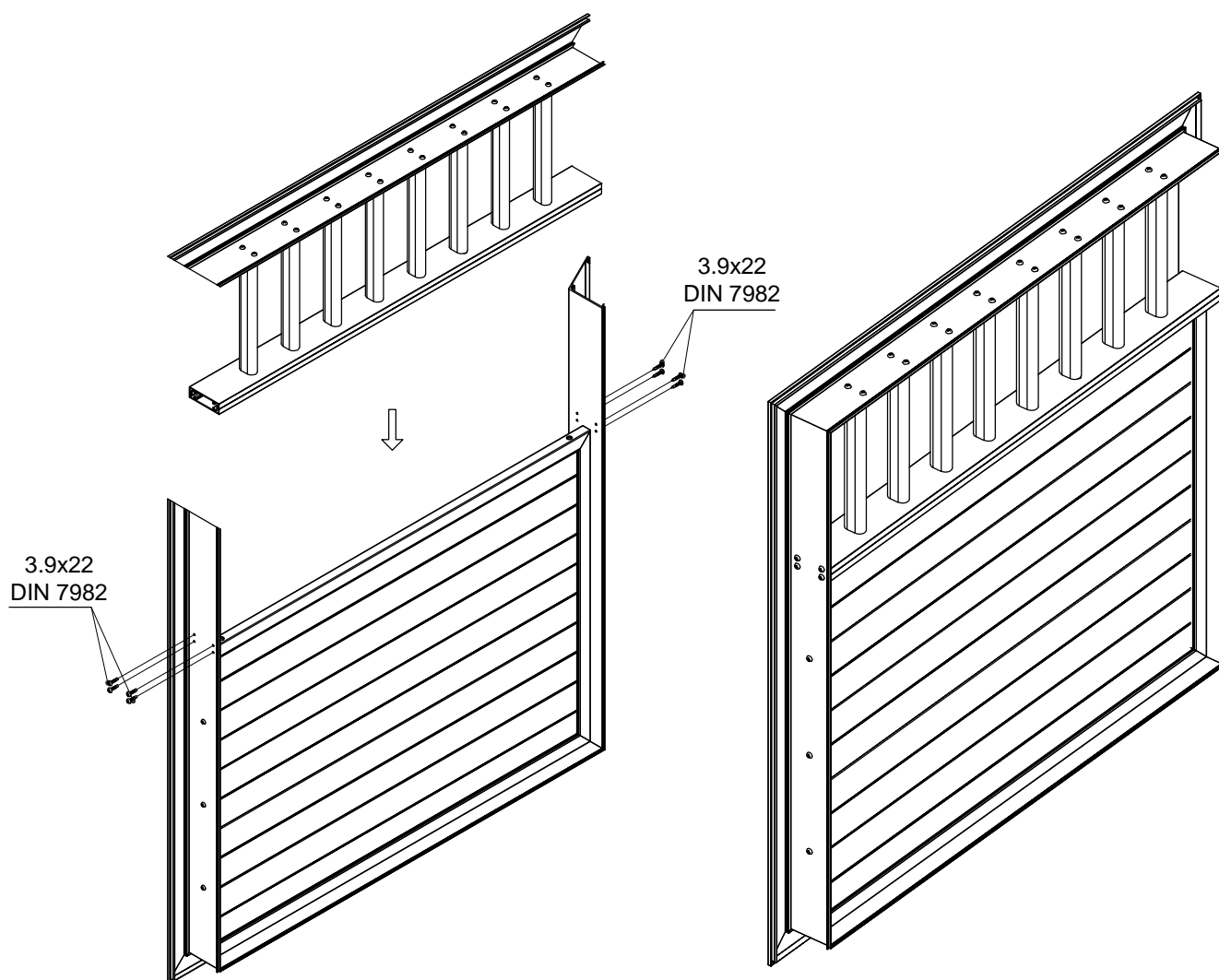
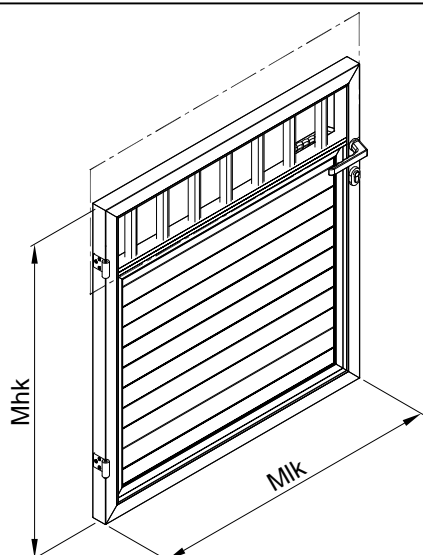

### OF-80 Tip KC-45

18. Postupak spajanja rama moždanika F-0032  
 Umetanje kutnih spojnica 710.073 u komora moždanika.

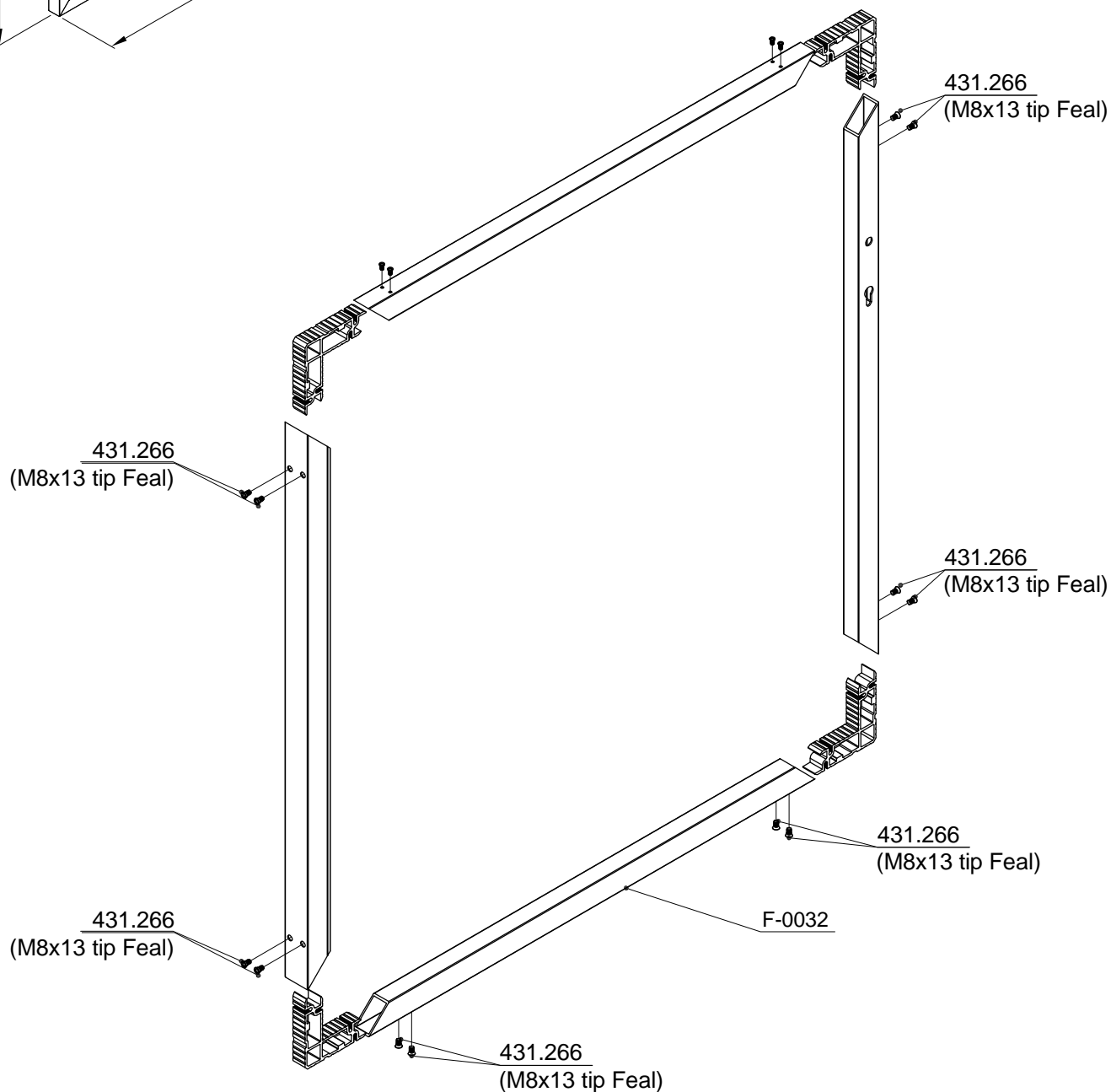
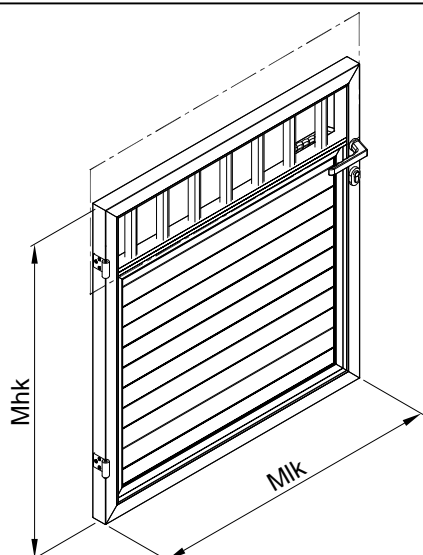

#### OF-80 Tip KC-45

##### 19. Postupak montaže moždanika rama F-0032:

19.1. Na sklopljeni segment montiramo moždanik F-0032 prema crtežu.

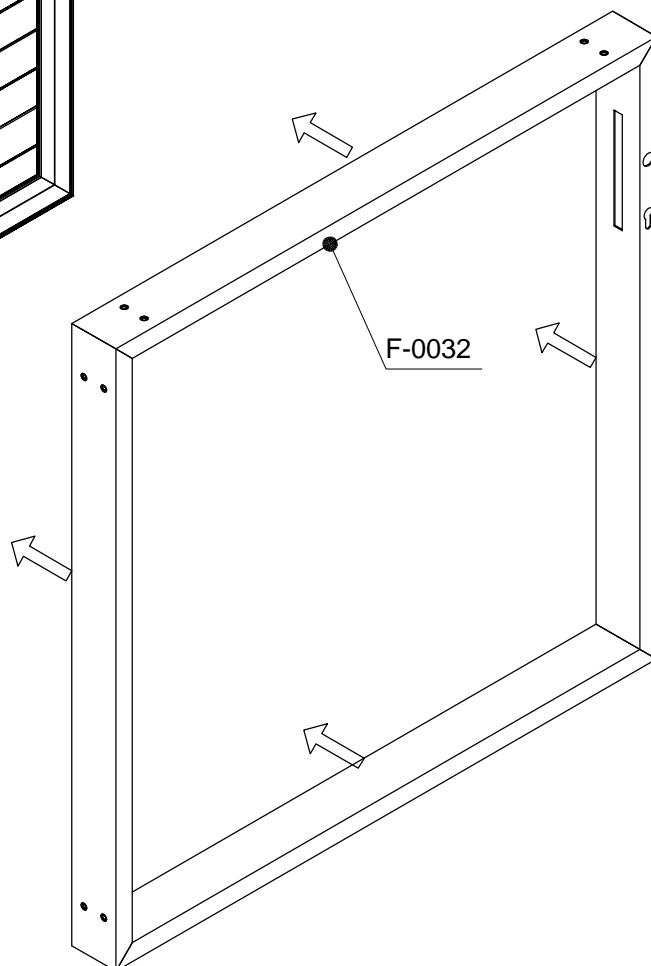
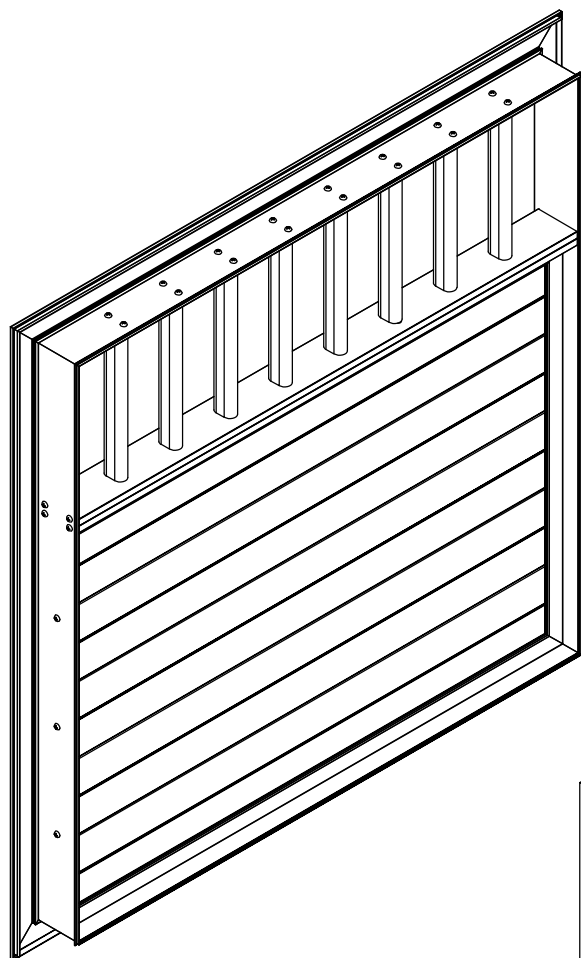
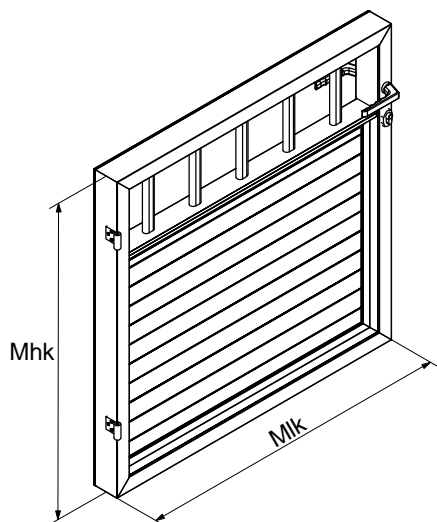

#### OF-80 Tip KC-45

#### 20. Postupak montaže vanjskog plašta kapije:

20.1. Na unutarnji plašt kapije klipsamo vanjski plašt kapije profila F-1659 prema crtežu

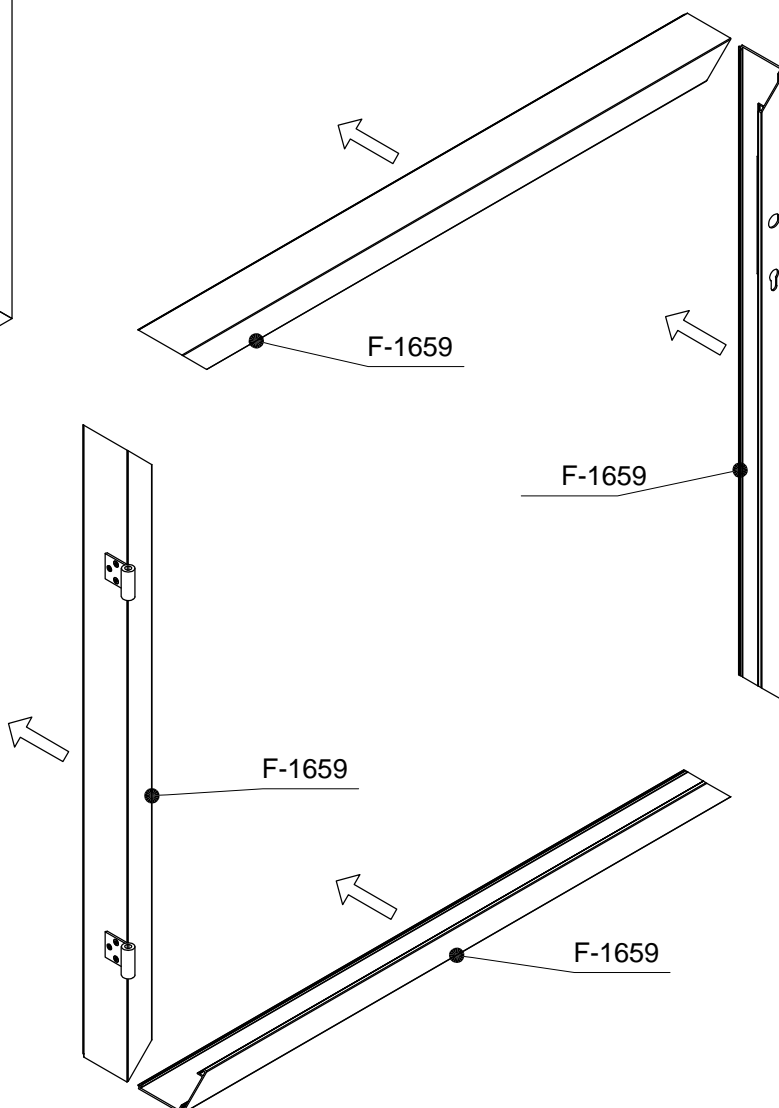
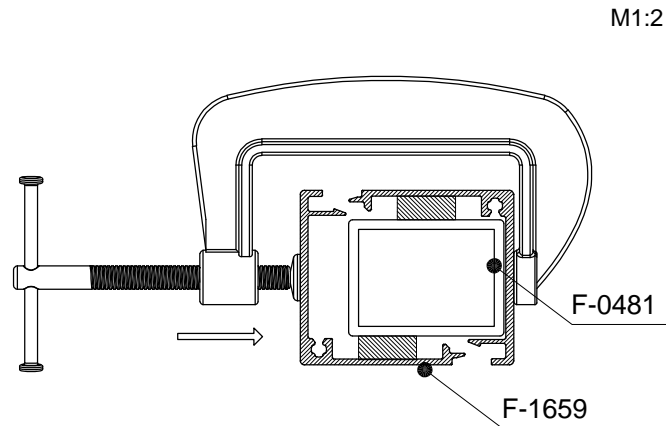
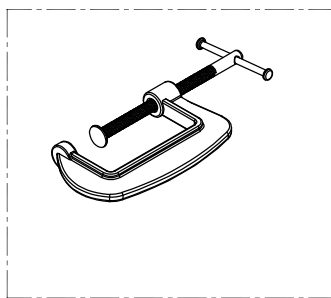
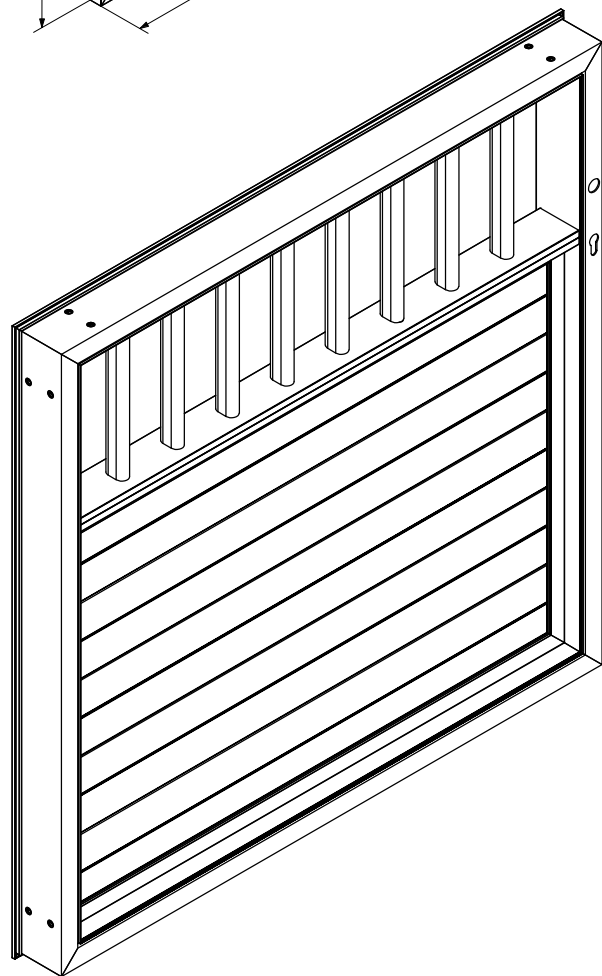
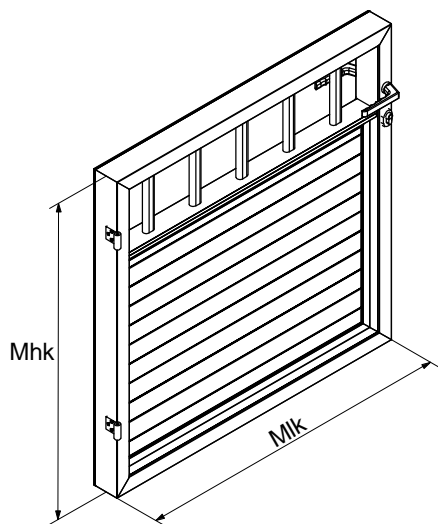

**NAPOMENA:**  
U slučaju teškog klipsanja koristiti stegu.

### OF-80 Tip KC-45

#### 21. Postupak ugradnje baglama na kapiju:

21.1. Baglame (111.027) vežemo za moždanik kroz profile F-1659 vijkom 4.8x32 DIN 7982

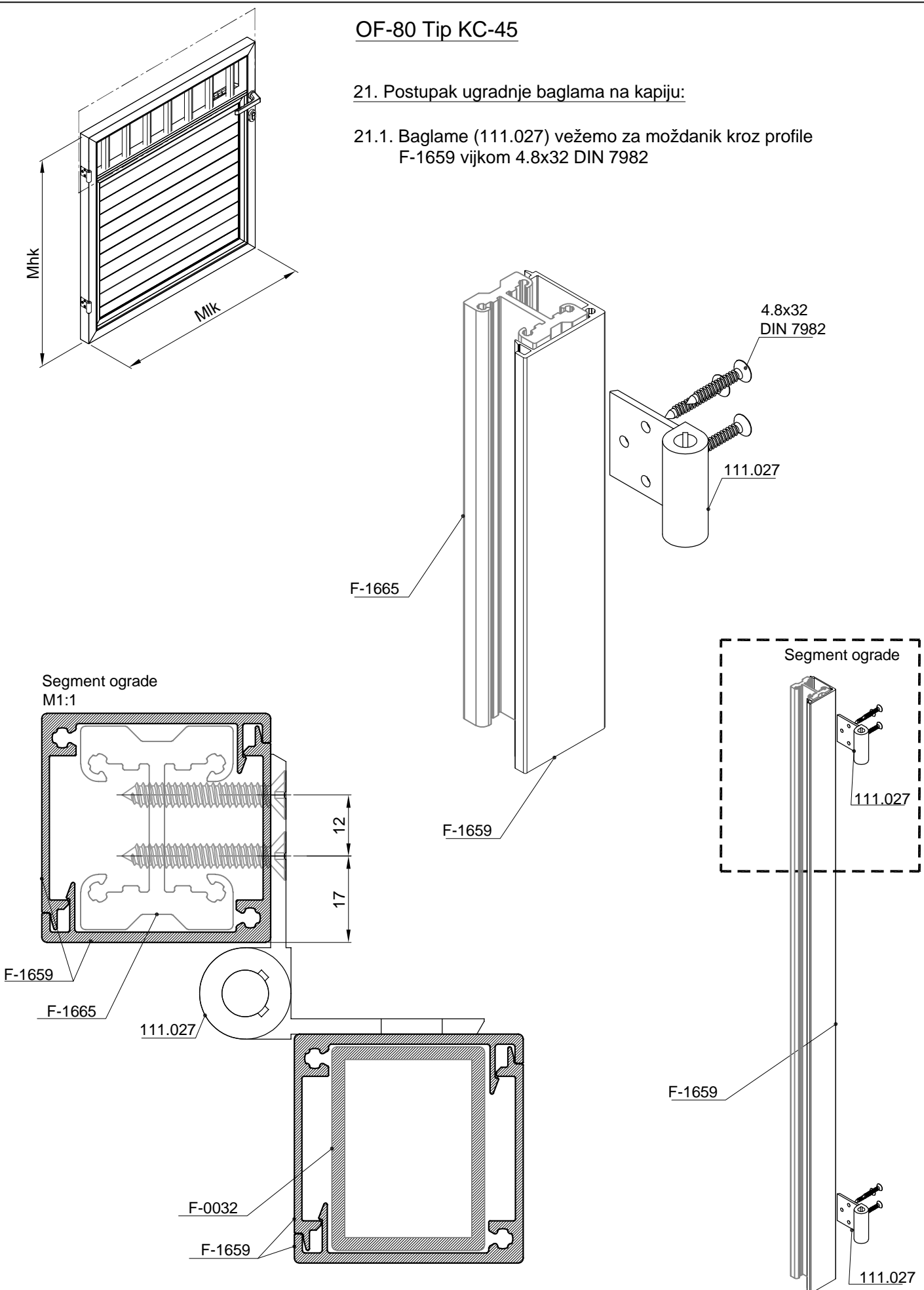

### OF-80 Tip KC-45

#### 22. Postupak ugradnje baglama na kapiju:

##### 22.1. Baglame (111.027) vežemo za pločicu kroz profile F-1666 vijkom 4.8x32 DIN 7982

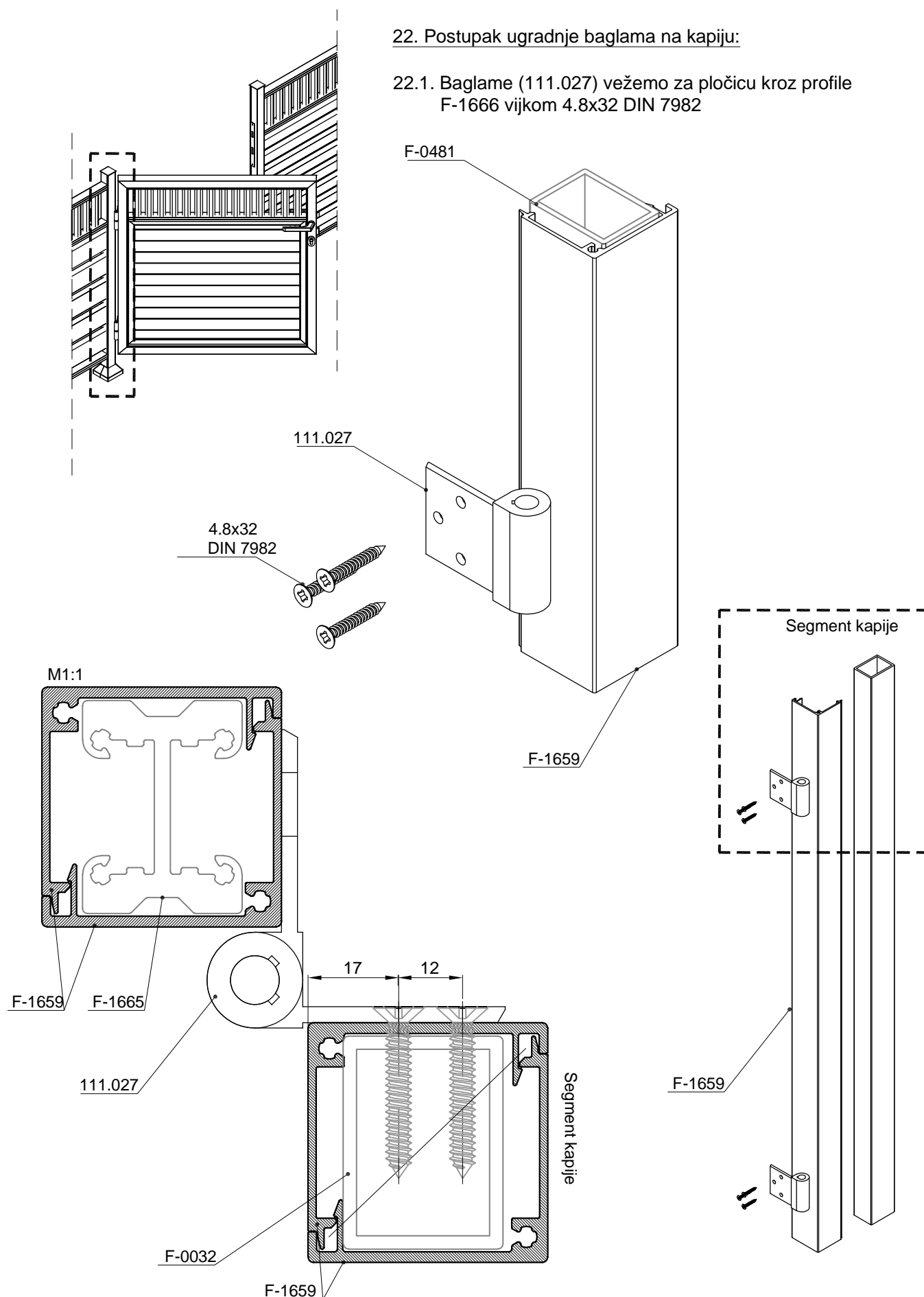

### OF-80 Tip KC-45

#### 23. Položaj ugradnje baglame

23.1. Montirati baglame na kapiju i ogradu prema crtežu

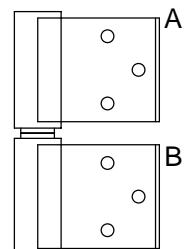
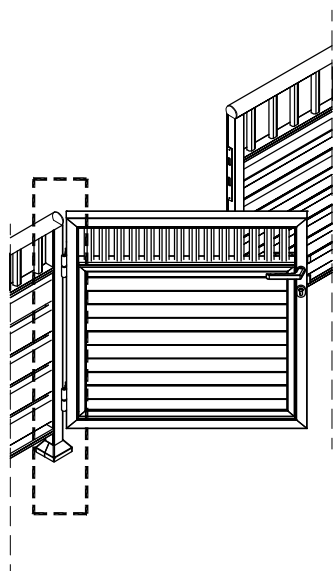

A-baglama na kapiji  
B-baglama na segmentu ogade

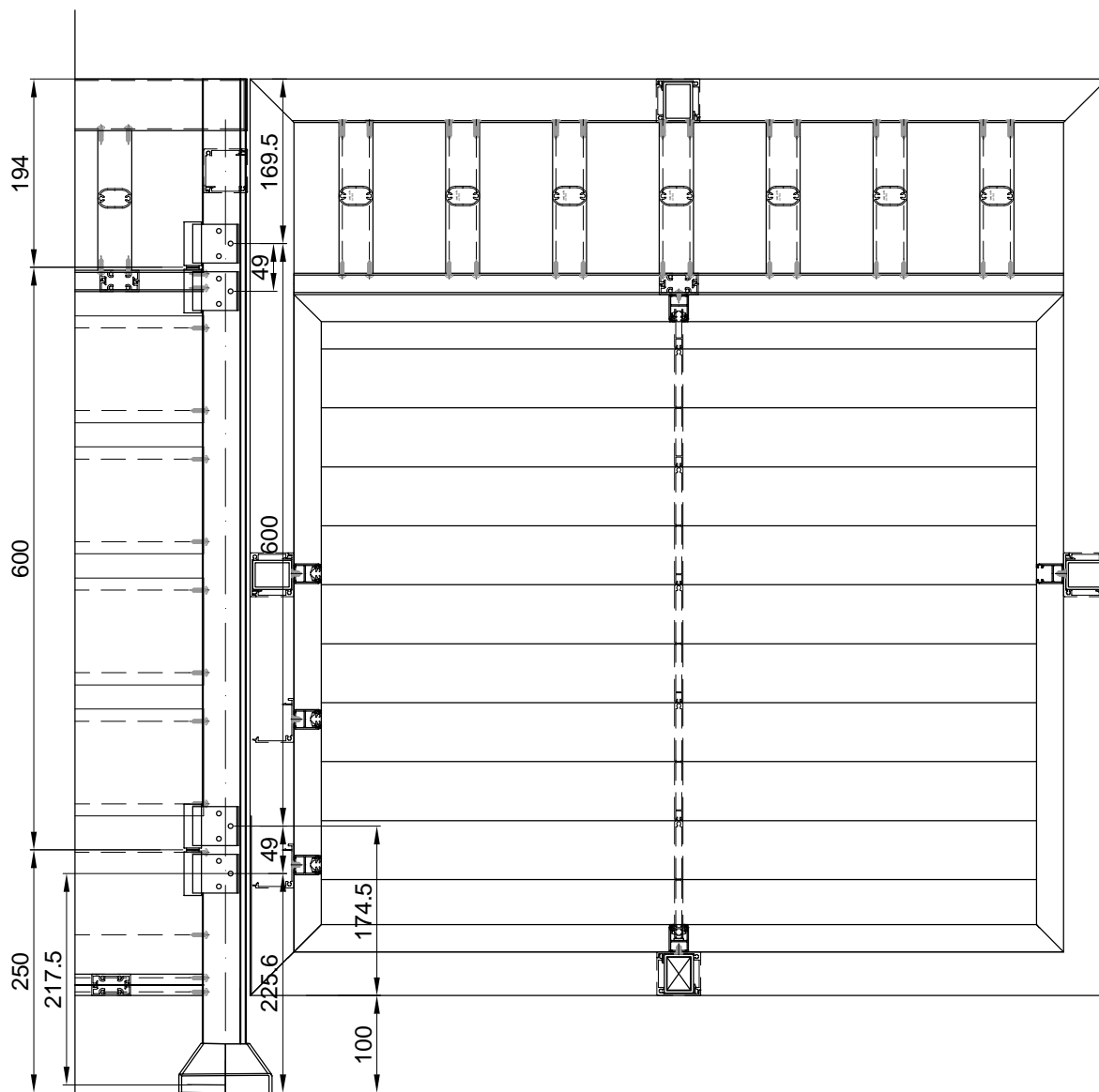

#### OF-80 Tip KC-45

24. Postupak montaže brave na kapiju:

24.1. Montiramo bravu prema shemi

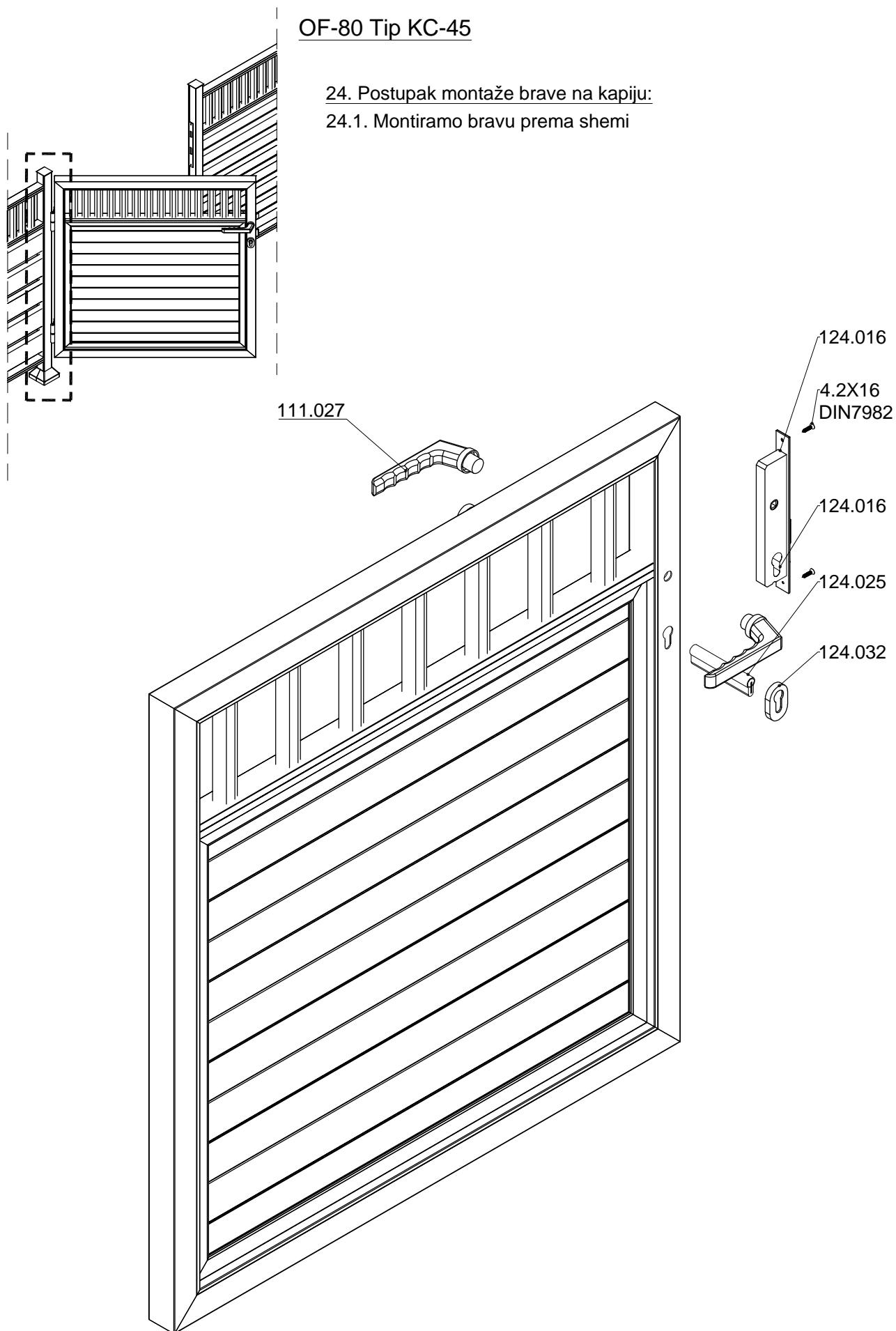

OF-80 Tip KC-45

25. Postupak montaže kapije:

25.1. Montiramo kapiju na segment ograde

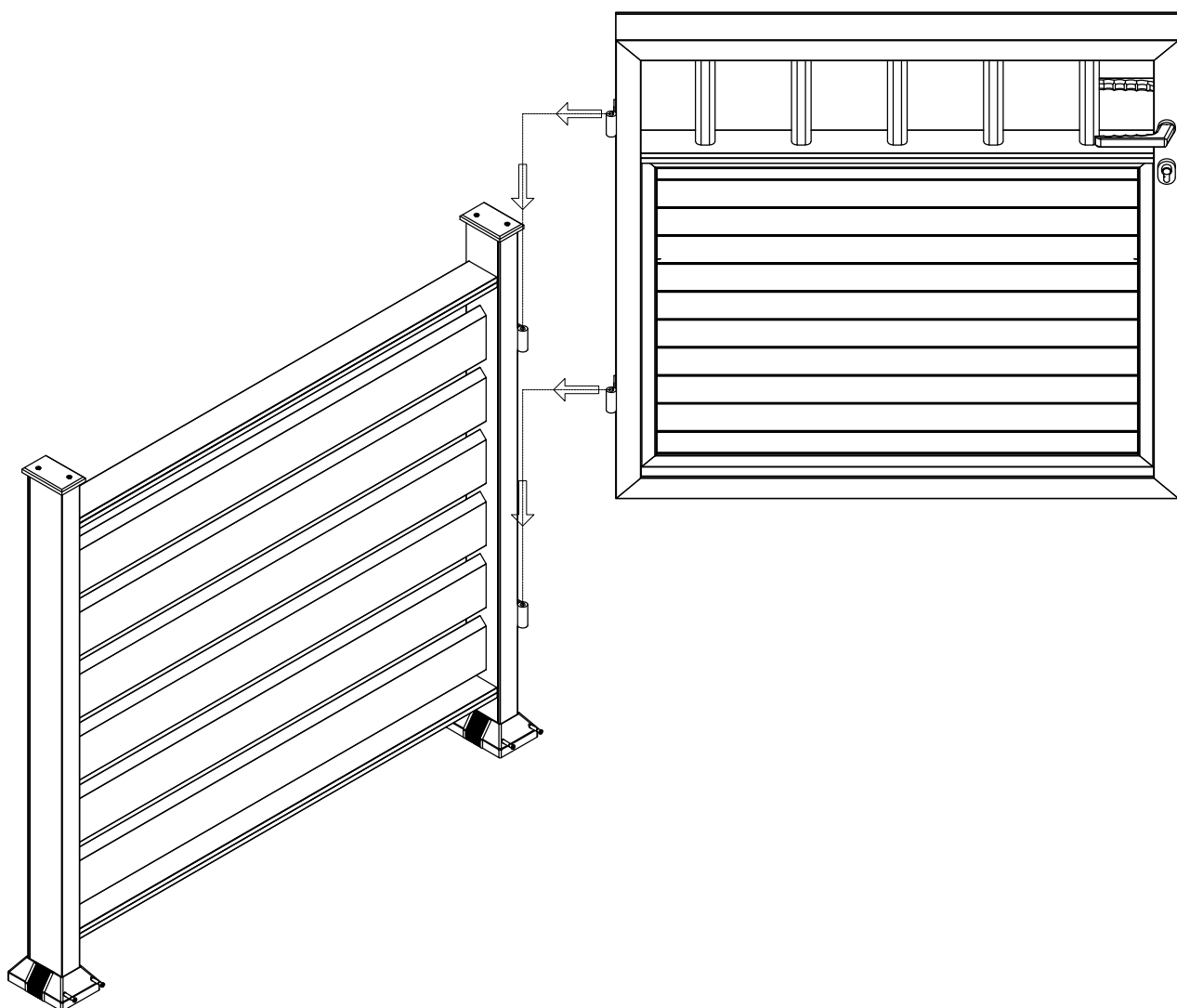
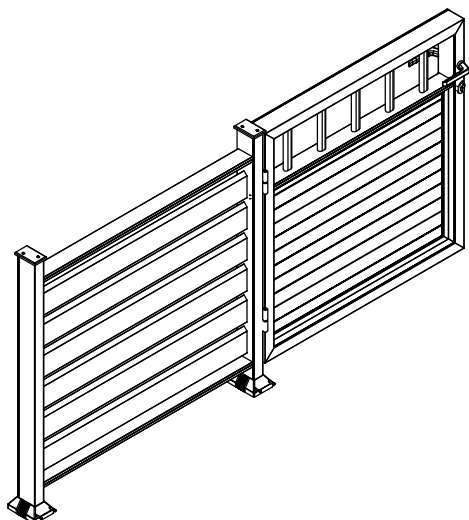

# FEAL



Skenirajte QR kod i registrirajte se na [partner.feal.ba](https://partner.feal.ba)

*Scan the QR code and register on [partner.feal.ba](https://partner.feal.ba)*

## OF 80

Kolovoz 2024./ August 2024

FEAL d.o.o.  
Trnska cesta 146  
88220 Široki Brijeg  
Bosna i Hercegovina  
Tel. +387 39 704-269; 705-807; 705-636  
Fax. +387 39 704-358  
[info@feal.ba](mailto:info@feal.ba)  
[www.feal.ba](http://www.feal.ba)