

FEAL

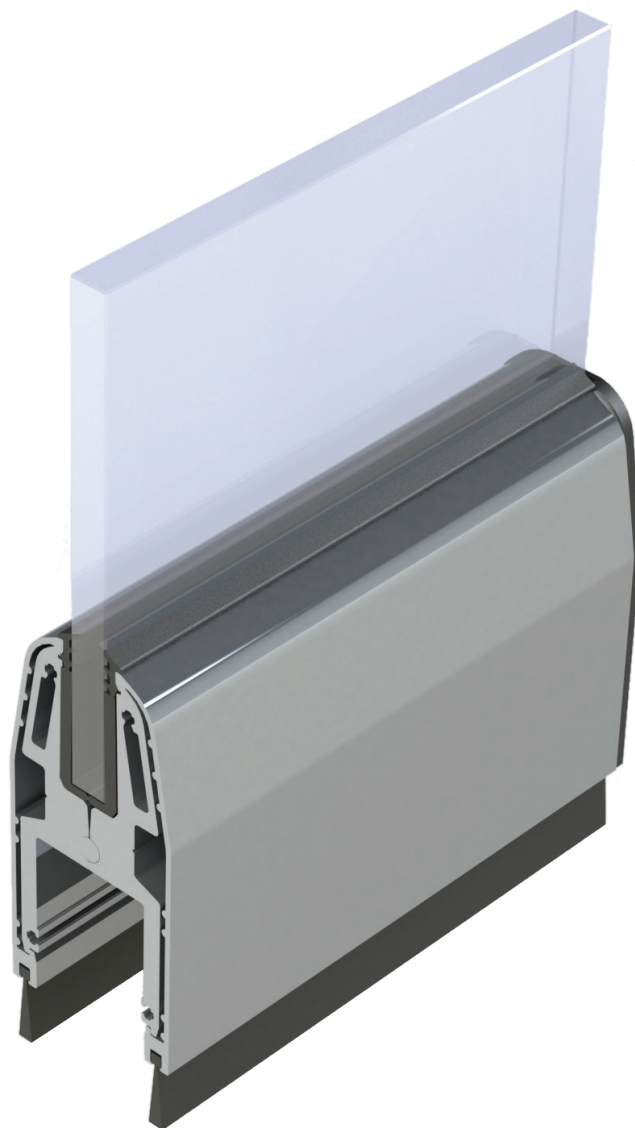

MF-45

STAKLENE MOBILNE STIJENE
GLASS MOBILE WALLS

SADRŽAJ

00	SADRŽAJ	706.00.000-000
01	ZNAČAJKE SISTEMA	706.01.000-000
03	PROFILI	706.03.000-005
04	VEZNI ELEMENTI	706.04.000-003
05	PVC ELEMENTI	706.05.000-003
06	MEHANIZMI	706.06.000-007
07	BRTVILA	706.07.000-003
08	DODACI	706.08.000-003
10	PRESJECI	706.10.000-023
11	OBRADA I MONTAŽA	706.11.000-045
12	REZNE LISTE	706.12.000-013

Značajke sistema

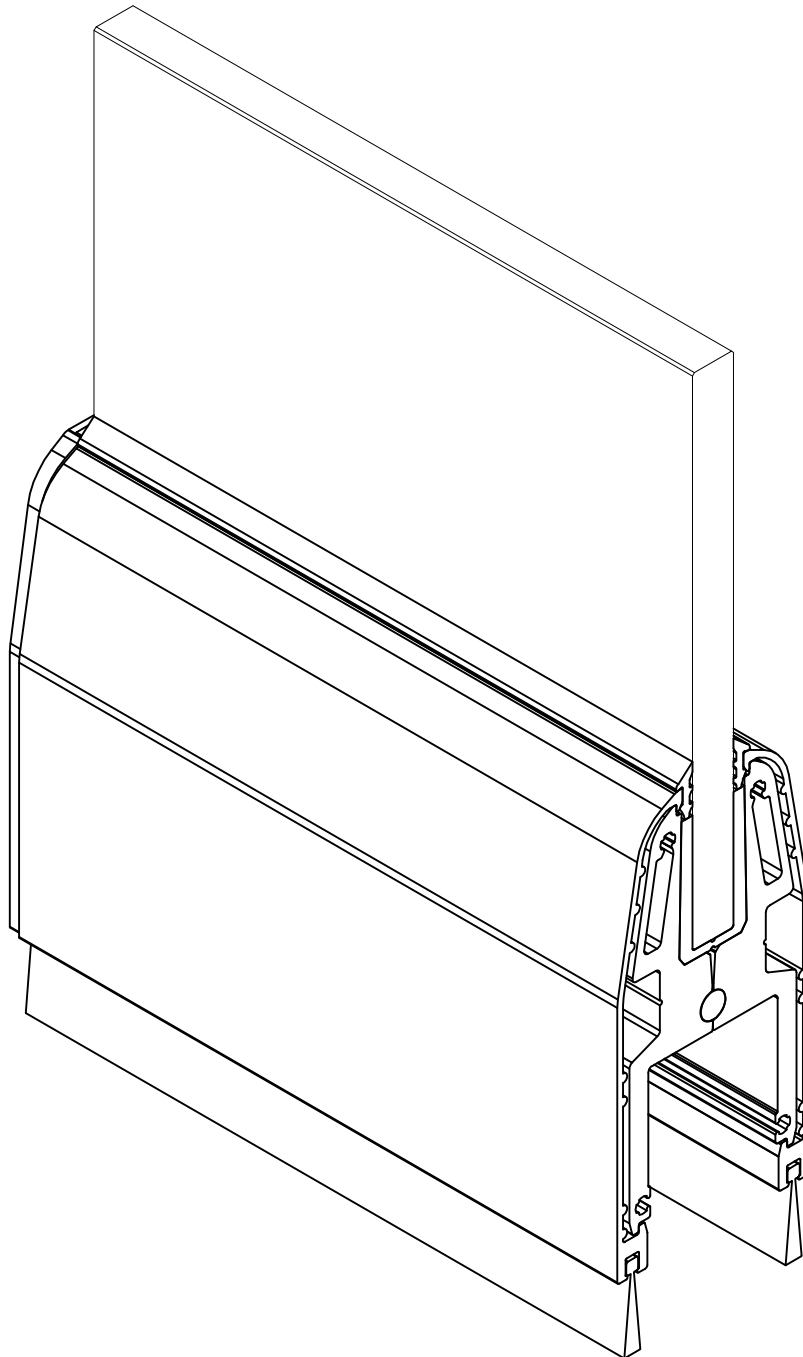

OPIS SISTEMA MF 45:

Sistem **MF 45** mobilne staklene stijene predstavljaju optimalnu kombinaciju multifunkcionalnosti, otvorenosti i transparentnosti. Ukoliko je vaša želja

razdvojiti prostoriju sa staklenim zidom, taj zid ne mora značiti stalnu podjelu prostorije.

Daleko prikladniji izbor su mobilne staklene stijene koje omogućuju podjelu između prostorija sukladno vašim potrebama. Ovakva

fleksibilnost je iznimno korisna u tržišnim centrima, izložbenim prostorima, ugostiteljskim objektima i privatnim rezidencijama kada je potreban puni pristup unutrašnjosti tijekom određenog perioda ili na mjestima gdje stakleni zidovi nude prostranost i njihova mobilnost omogućuje brzu reorganizaciju prostora. MF 45 omogućuje i ugradnju zaokretnih vrata, što

omogućuje prolaz između prostorija i kada su mobilne stijene zatvorene.

Tehničke karakteristike sistema:

-Lamistal kaljeno staklo 5.5.2 i 6.6.2

-Odabir različitih površinskih obrada stakla (prozirno, obojano, pjeskareno, printano)

-Odabir različitih površinskih obrada aluminija (RAL boje, eloksaža)

-Bez bočnih profila

-Bez podnih vodilica

-Automat u krilu za zaokretna vrata - bez obrada u podu

-Nošenje krila u dvije točke za laganije kretanje krila

-Dubina gornjeg i donjeg horizontalnog sklopa - 45 mm

Profili

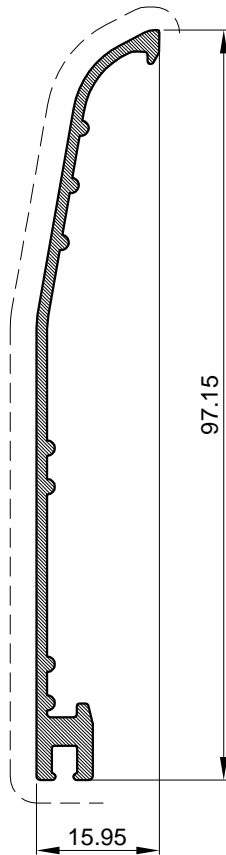

Poklopna lajsna		
Art.Br.	F-1472	
Težina	kg/m	0.53
Opseg	mm	224.64
Moment inercije	I_x (cm ⁴)	20.05
	I_y (cm ⁴)	0.26
	W_x (cm ³)	3.75
	W_y (cm ³)	0.2
L	mm	≤6800

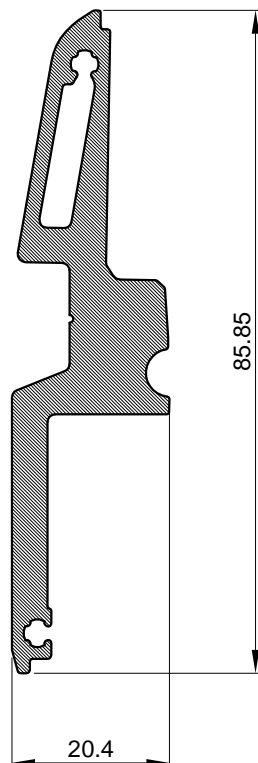

Poklopna lajsna		
Art.Br.	F-1473	
Težina	kg/m	1.59
Opseg	mm	224.64
Moment inercije	I_x (cm ⁴)	23.81
	I_y (cm ⁴)	1.63
	W_x (cm ³)	5.36
	W_y (cm ³)	1.35
L	mm	≤6800

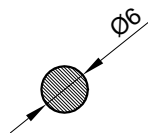
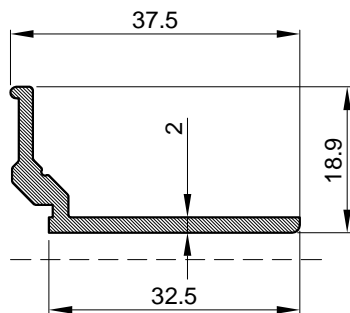
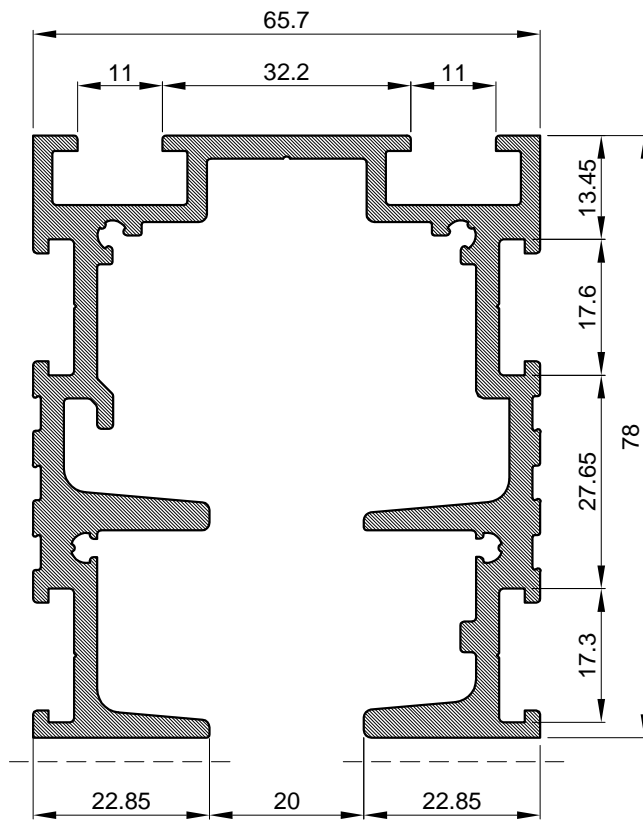

Profil vodilice - harmo stijene		
Art.Br.	F-1143	
Težina	kg/m	3.068
Opseg	mm	733.8
Moment inercije	I_x (cm ⁴)	73.6372
	I_y (cm ⁴)	69.8967
	W_x (cm ³)	18.4155
	W_y (cm ³)	21.1359
L	mm	6500

Profil za vodilicu		
Art.Br.	F-1424	
Težina	kg/m	0.306
Opseg	mm	109.7
Moment inercije	I_x (cm ⁴)	0.2943
	I_y (cm ⁴)	1.4932
	W_x (cm ³)	0.204
	W_y (cm ³)	0.621
L	mm	6500

Osovinica stope		
Art.-Br.	F-0021	
Težina	kg/m	0.076
Opseg	mm	18.85
L	mm	6500

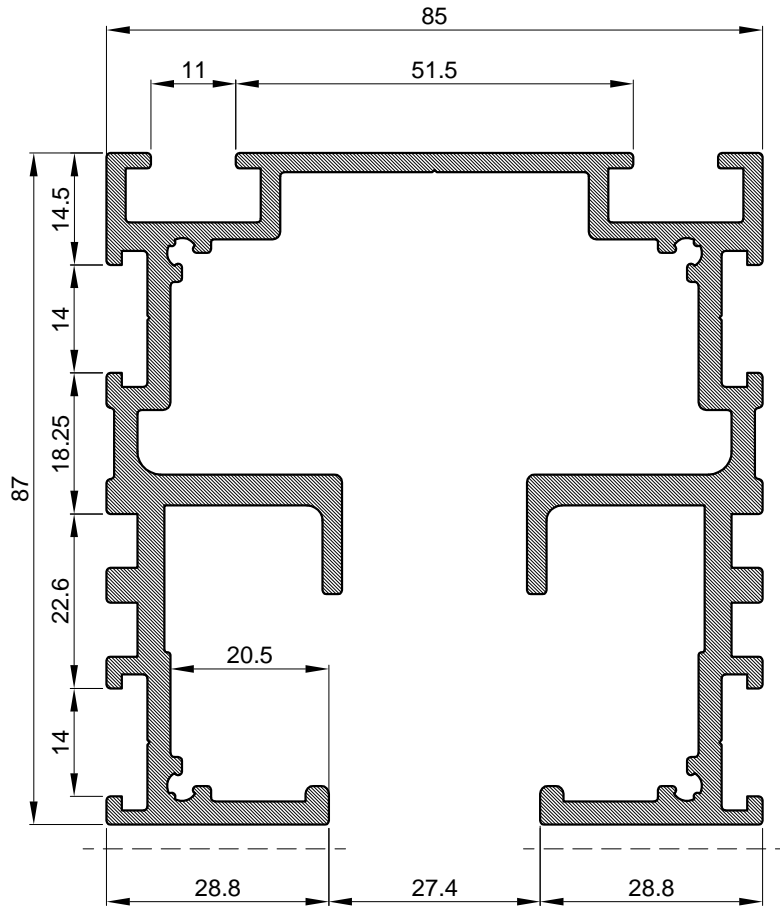

Profil dvostruke vodilice - mobilne stijene		
Art.Br.	F-1504	
Težina	kg/m	3.78
Opseg	mm	930.23
Moment inercije	I_x (cm ⁴)	107.9013
	I_y (cm ⁴)	142.6922
	W_x (cm ³)	24.069
	W_y (cm ³)	33.5746
L	mm	6500

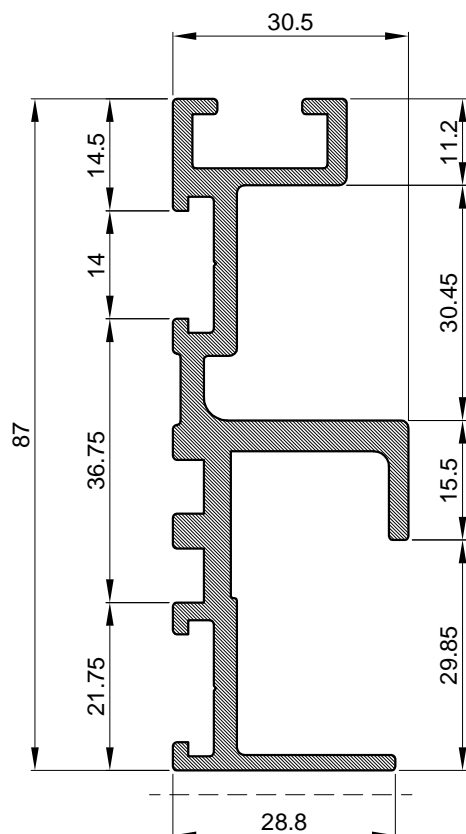

Profil jednostruke vodilice - mobilne stijene		
Art.Br.	F-1505	
Težina	kg/m	1.64
Opseg	mm	411.71
Moment inercije	I_x (cm ⁴)	39.0411
	I_y (cm ⁴)	4.4727
	W_x (cm ³)	8.9729
	W_y (cm ³)	2.2055
L	mm	6500

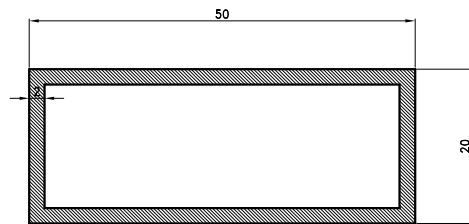

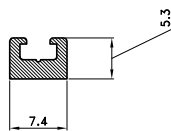

Profil za zidnu baglamu		
Art.Br.	F-0198	
Težina	kg/m	0.71
Opseg	mm	264
Moment inercije	I_x (cm ⁴)	1.7632
	I_y (cm ⁴)	1.7362
	W_x (cm ³)	7.8552
	W_y (cm ³)	3.142
L	mm	6500



Profil za zidnu blaglamu		
Art.-Br.	F-1357	
Težina	kg/m	0.07
Opseg	mm	33.91
L	mm	6500

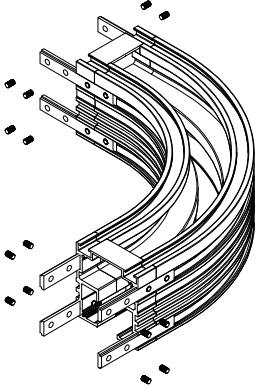
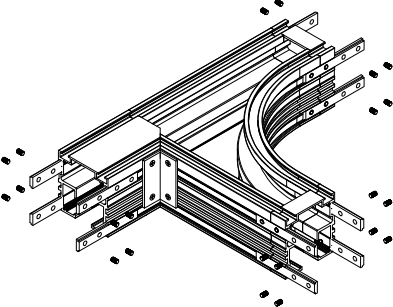
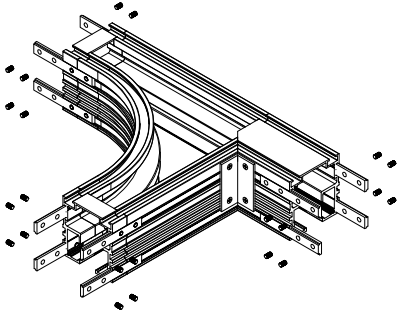
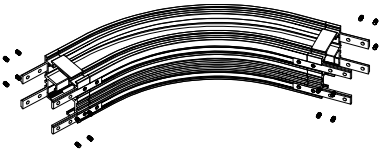

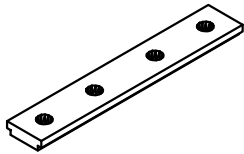
Vezni elementi

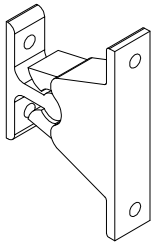
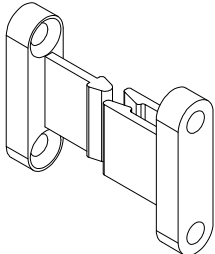
Oznaka		Opis	Materijal	Napomena
391.120		- Sklop skretanja 90° - Vodilica F-1504	Al.	
391.121		- Sklop račvanja lijevo - Vodilica F-1504	Al.	
391.122		- Sklop račvanja desno - Vodilica F-1504	Al.	
391.161		- Sklop skretanja 120° - Vodilica F-1504	Al.	

Oznaka	Izgled-presjek	Opis	Materijal	Napomena
391.019		- Pločica (100x17x5) - za spajanje vodilica (F-1143;F-1504;F-1505)	Al.	
390.023		- Osovina Ø7/23	Inox	
724.021		- Držać	Kromirani Zamak	
724.022		- PVC držać krila	PVC	

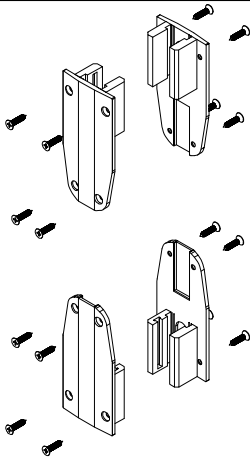
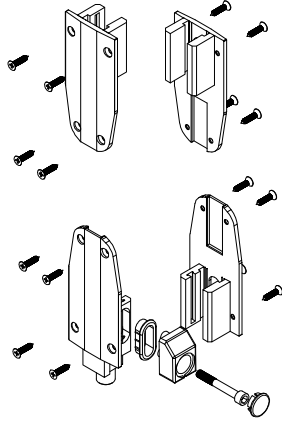
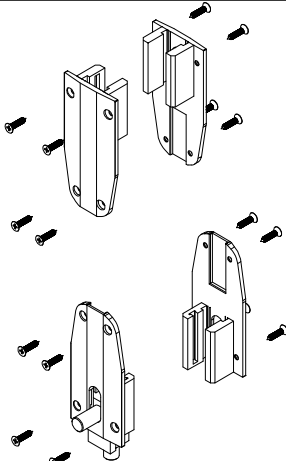
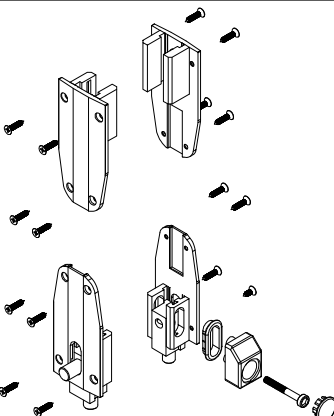
PVC elementi

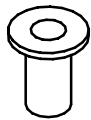
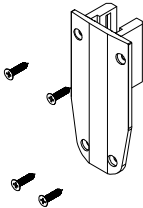
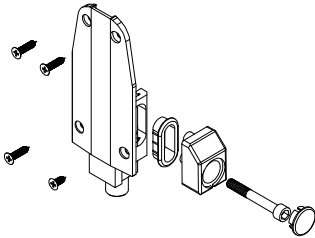
Oznaka		Opis	Materijal	Napomena
301.039.01 .02 .03		- Set čepova za mimokretna vrata	PVC	
301.040.01 .02 .03		- Set čepova prvog kliznog krila	PVC	
301.041.01 .02 .03		- Set čepova za srednjih krila	PVC	
301.042.01 .02 .03		- Set čepova zadnjeg krila	PVC	

Oznaka	Izgled-presjek	Opis	Materijal	Napomena
375.049		- Poliamidna čahura manja L=12.5 mm - Za osiguranje stakla	PA 66	
301.043.01 .02 .03		- Čep zatvoreni	PVC	
301.044.01 .02 .03		- Čep zatvoreni	PVC	
301.046		- Odstojnik za krila		

Mehanizmi

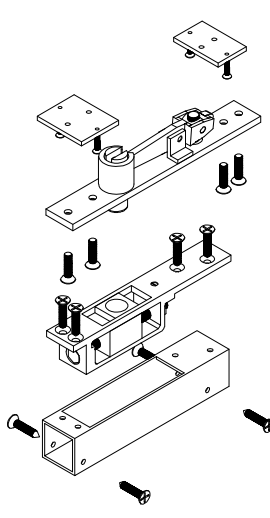
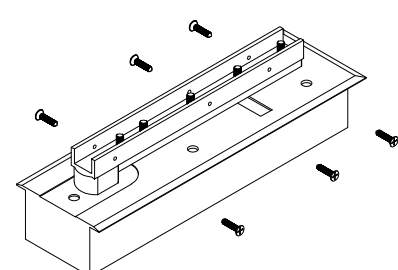
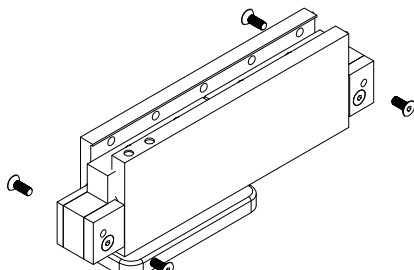
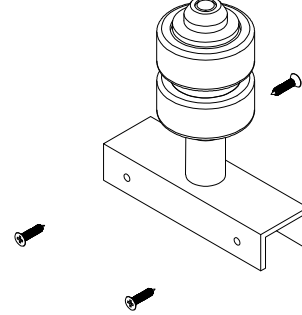
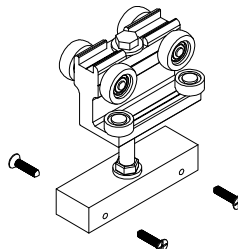
Oznaka	Izgled-presjek	Opis	Materijal	Napomena
146.007		- Sklop gornjeg mehanizma mimokretnih vrata	-	
146.008		- Automat u podu mimokretnih vrata	-	
140.072		- Automat u krilu mimokretnih vrata	-	
140.065		- Kotačić kliznog krila	-	
521.212		- Kolica MF-45	-	

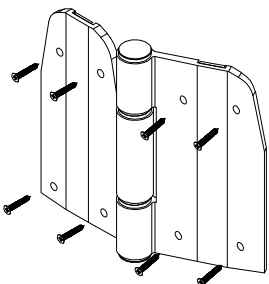
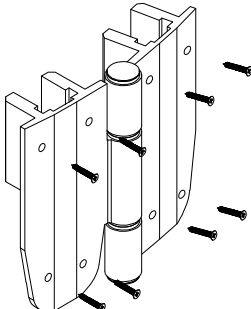
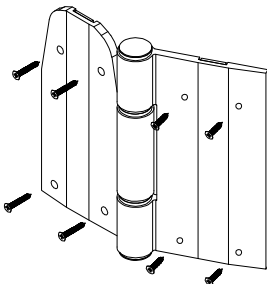
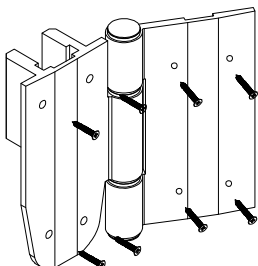
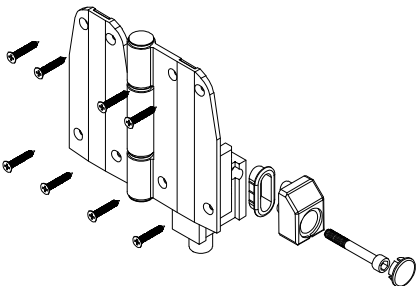

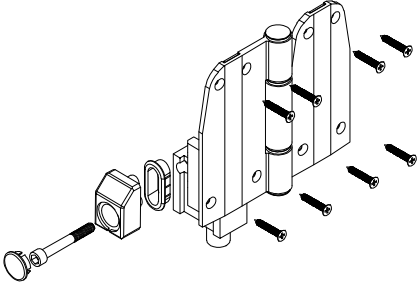

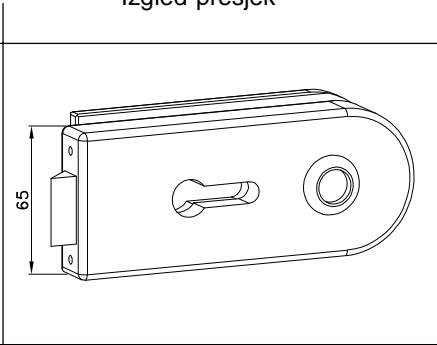
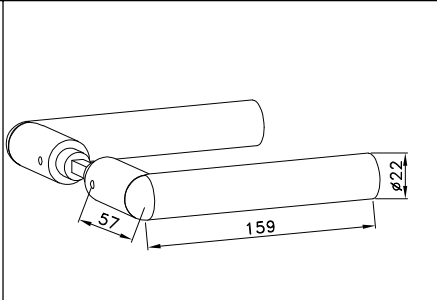
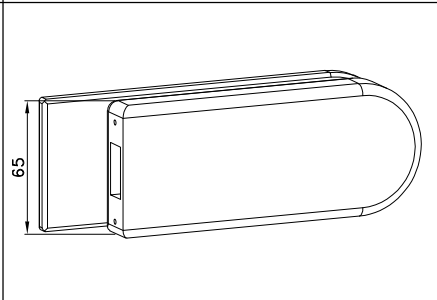
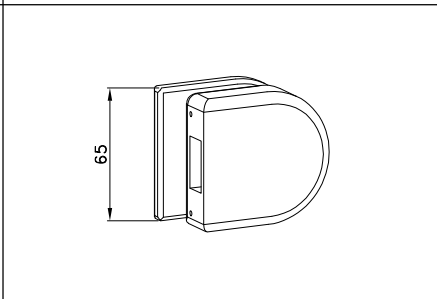
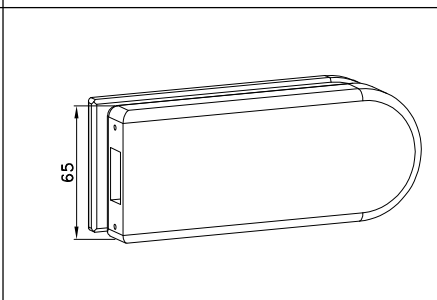
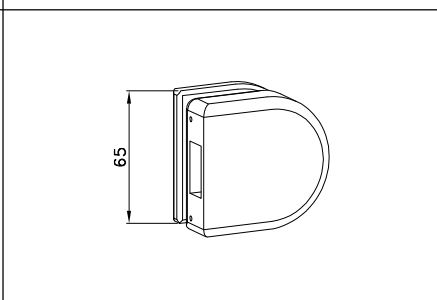
Oznaka	Izgled-presjek	Opis	Materijal	Napomena
111.016		- Međukrilna šarka Tip A - Harmonika otvaranje	-	Dostupna površinska obrada prema ELOX karti
111.017		- Međukrilna šarka Tip B - Harmonika otvaranje	-	Dostupna površinska obrada prema ELOX karti
111.018		- Šarka između zida i vrata Tip A - Harmonika otvaranje	-	Dostupna površinska obrada prema ELOX karti
111.019		- Šarka između zida i vrata Tip B - Harmonika otvaranje	-	Dostupna površinska obrada prema ELOX karti
111.020		- Međukrilna šarka Tip C - Harmonika otvaranje	-	Dostupna površinska obrada prema ELOX karti

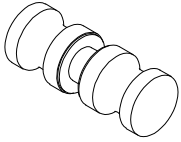
Oznaka	Izgled-presjek	Opis	Materijal	Napomena
111.021		<ul style="list-style-type: none"> - Međukrilna šarka Tip D - Harmonika otvaranje 	-	Dostupna površinska obrada prema ELOX karti

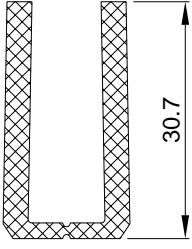

Oznaka	Izgled-presjek	Opis	Materijal	Napomena
120.008		- Brava za staklena vrata	-	
120.009		- Ručka za staklena vrata	-	
120.010		- Pihvatnik brave za staklena vrata - Otvaranje 90° - Za tip otvaranja 1,3,4.	-	
120.011		- Pihvatnik brave za staklena vrata (mali) - Otvaranje 90° - Za tip otvaranja 1,3,4.	-	
120.014		- Pihvatnik brave za staklena vrata - Otvaranje 180° - Za tip otvaranja 2	-	
120.015		- Pihvatnik brave za staklena vrata (mali) - Otvaranje 180° - Za tip otvaranja 2	-	

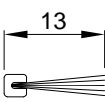
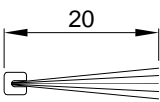
Oznaka	Izgled-presjek	Opis	Materijal	Napomena
100.013		<ul style="list-style-type: none">- Ručka za staklena vrata- Visina od stakla 30 mm	Kromirani mesing	

Brtvila

Oznaka	Izgled-presjek	Opis	Materijal	Napomena
344.070		- Brtva u stopi mobilne stijene	TPE	83
311.001		- Brtva u staklu	EPDM	75
347.008		- Četkasta brtva 13 mm	PP	
347.010		- Četkasta brtva 20 mm	PP	
314.001		- Brtva u zidu	TPE	65

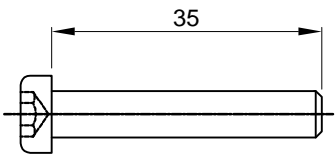
Dodaci

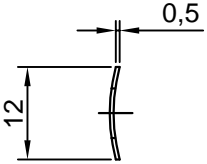
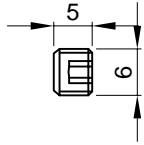
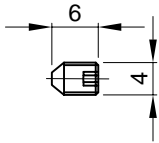
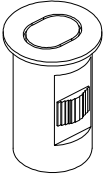
Oznaka	Izgled-presjek	Opis	Materijal	Napomena
431.914		- M6x35 DIN 912	Inox	
432.013		- Matica M6 DIN 985	Inox	
432.128		- Podloška M6 DIN 137 B	-	
431.737		- M6x5 DIN 913	Inox	
431.314		- M4x6 DIN 914	Inox	
120.013		- Podna čahura za osovinu Ø8.5x11.5 mm	Pocinčani čelik	

Presjeci

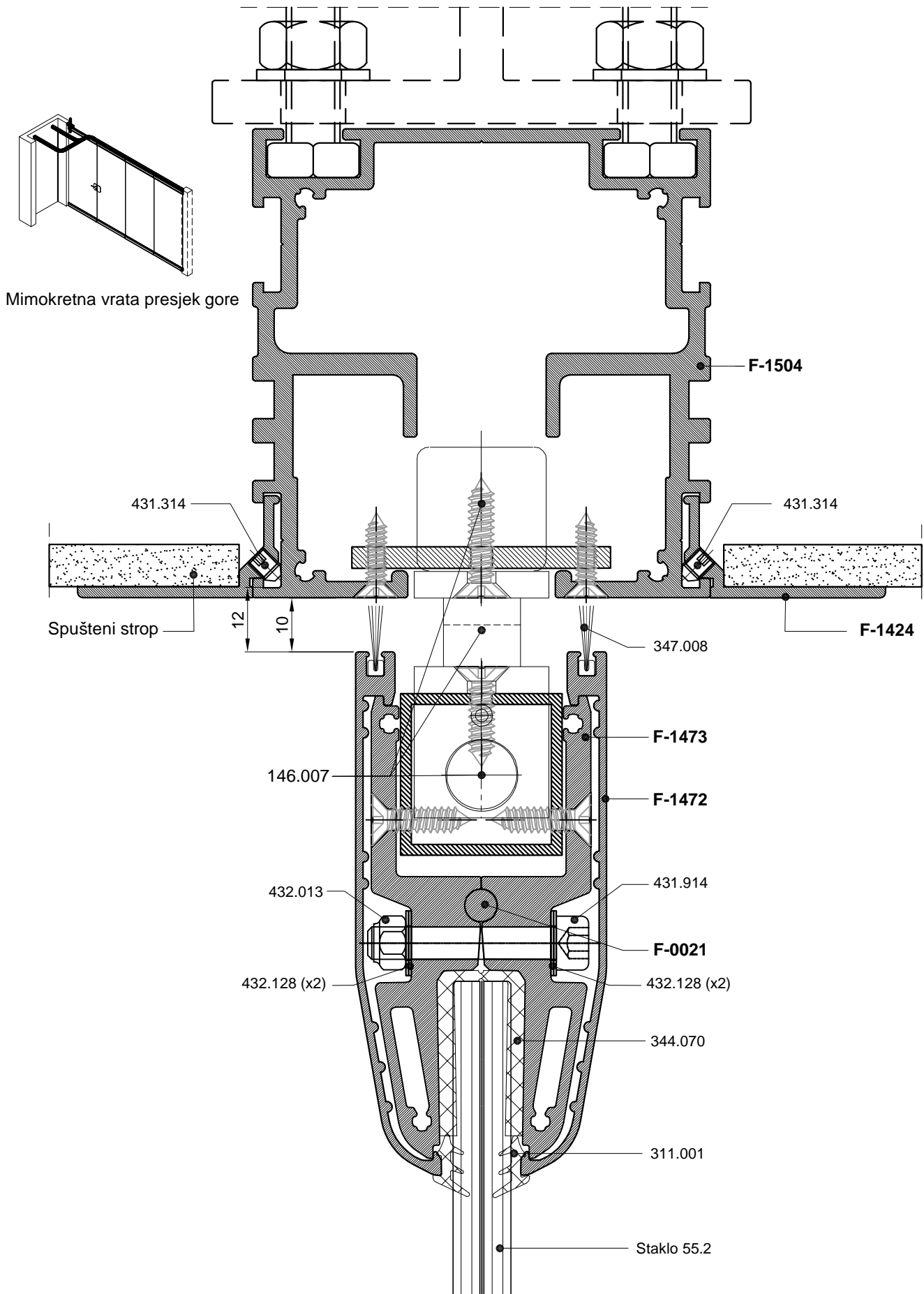

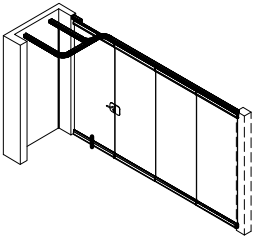

Mimokretna vrata presjek dolje automat u podu - 146.008

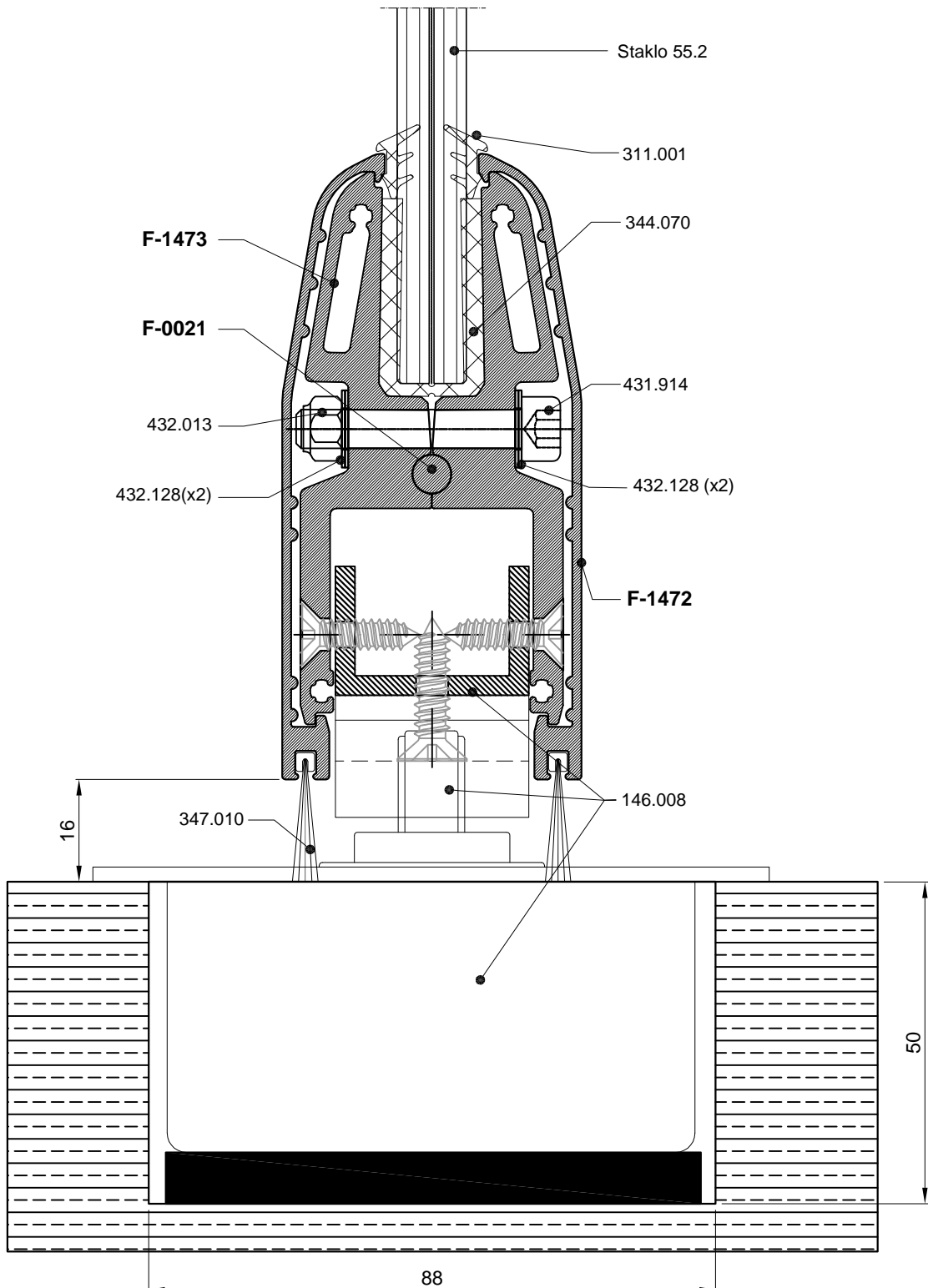

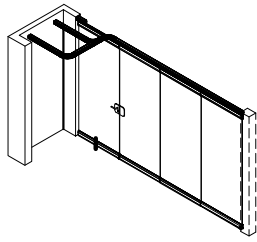

Mimokretna vrata presjek dolje automat u krilu - 140.072

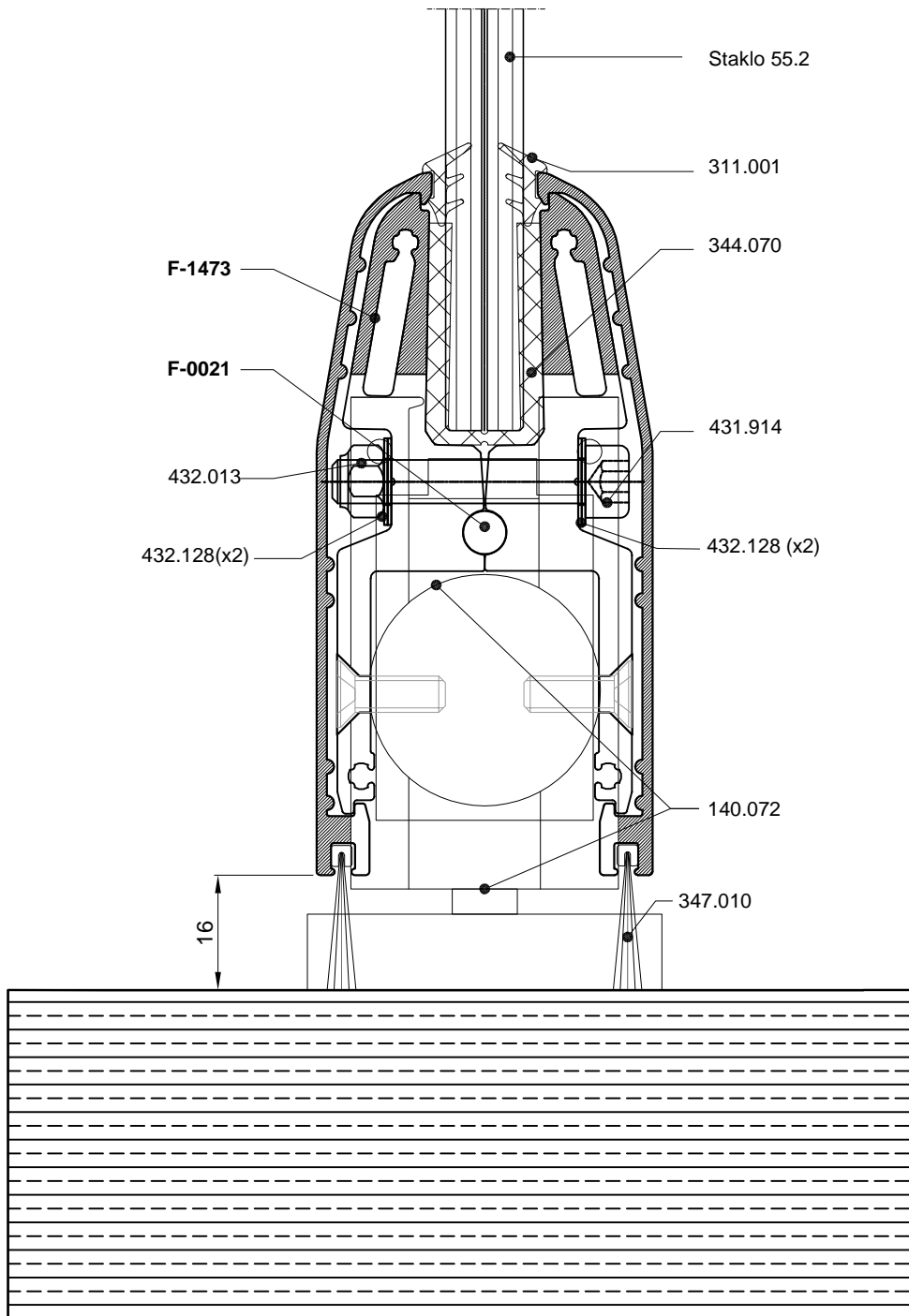

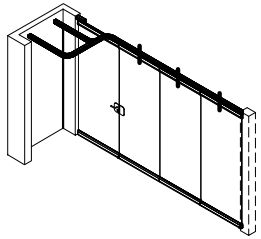

Klizna vrata presjek gore

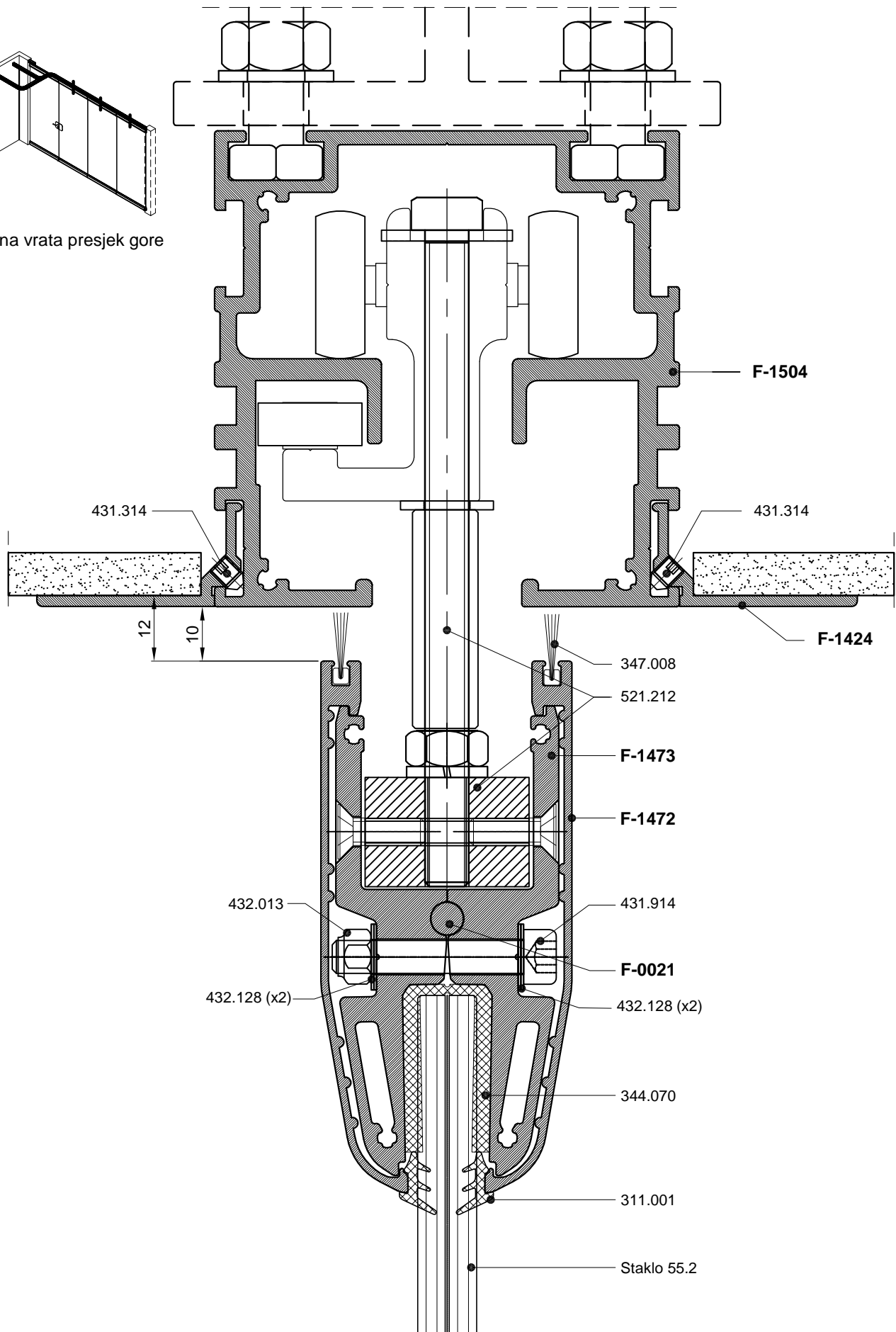

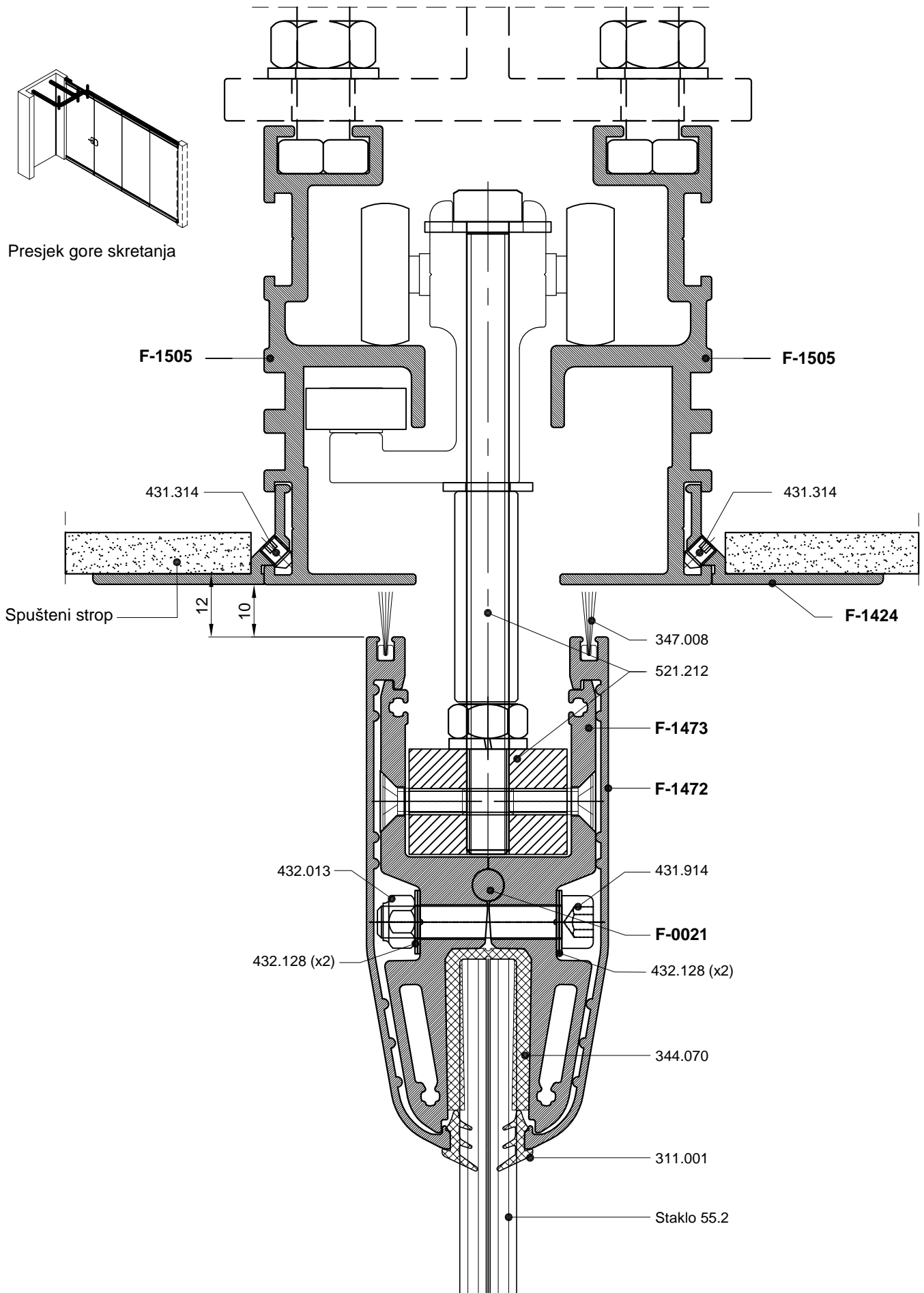

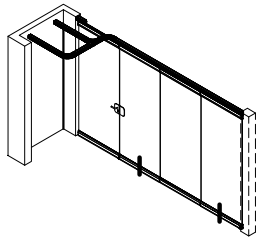

Klizna krila prvo i zadnje presjek - dolje

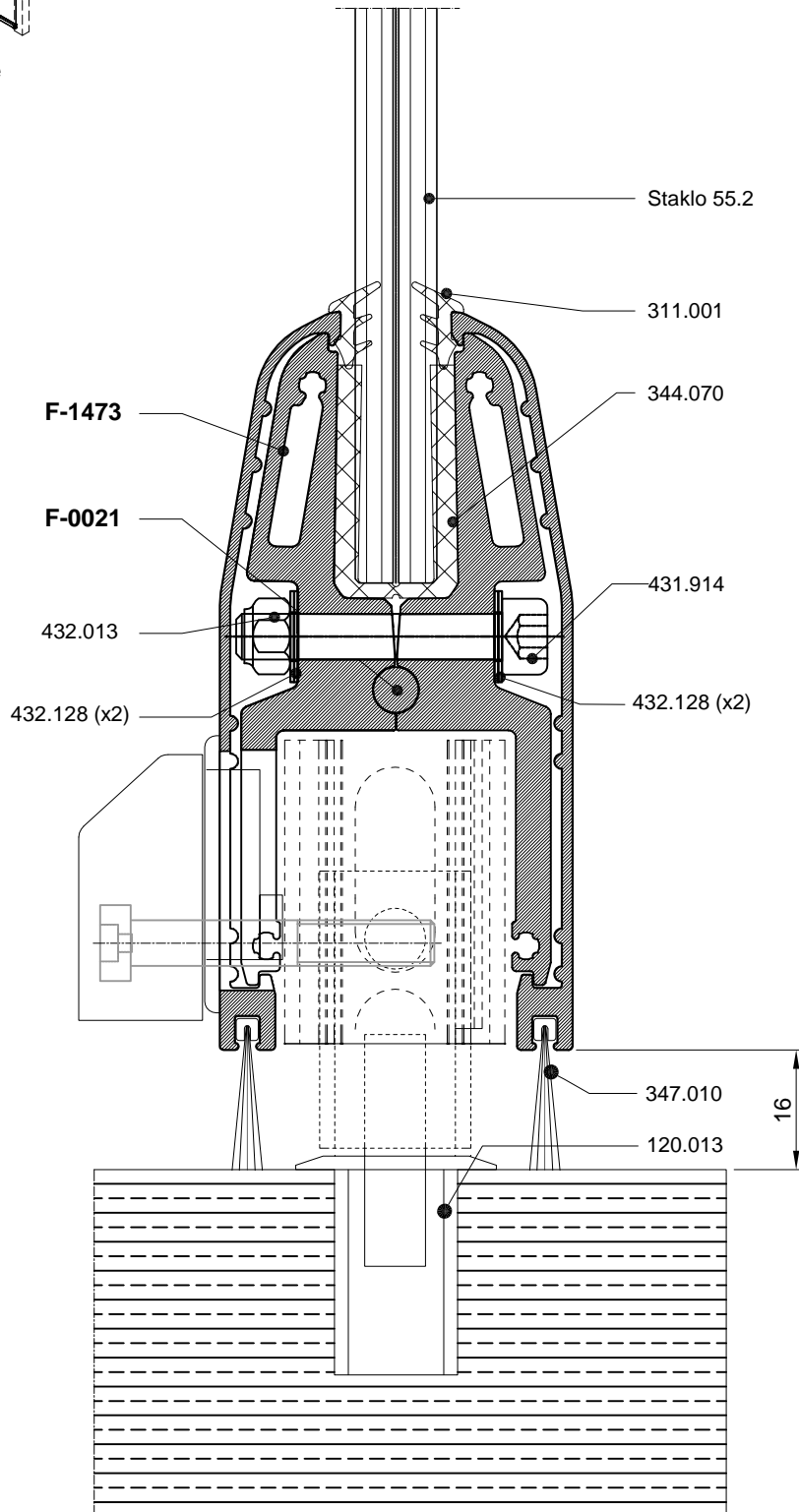

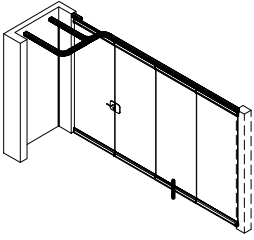

Srednja klizna krila presjek - dolje

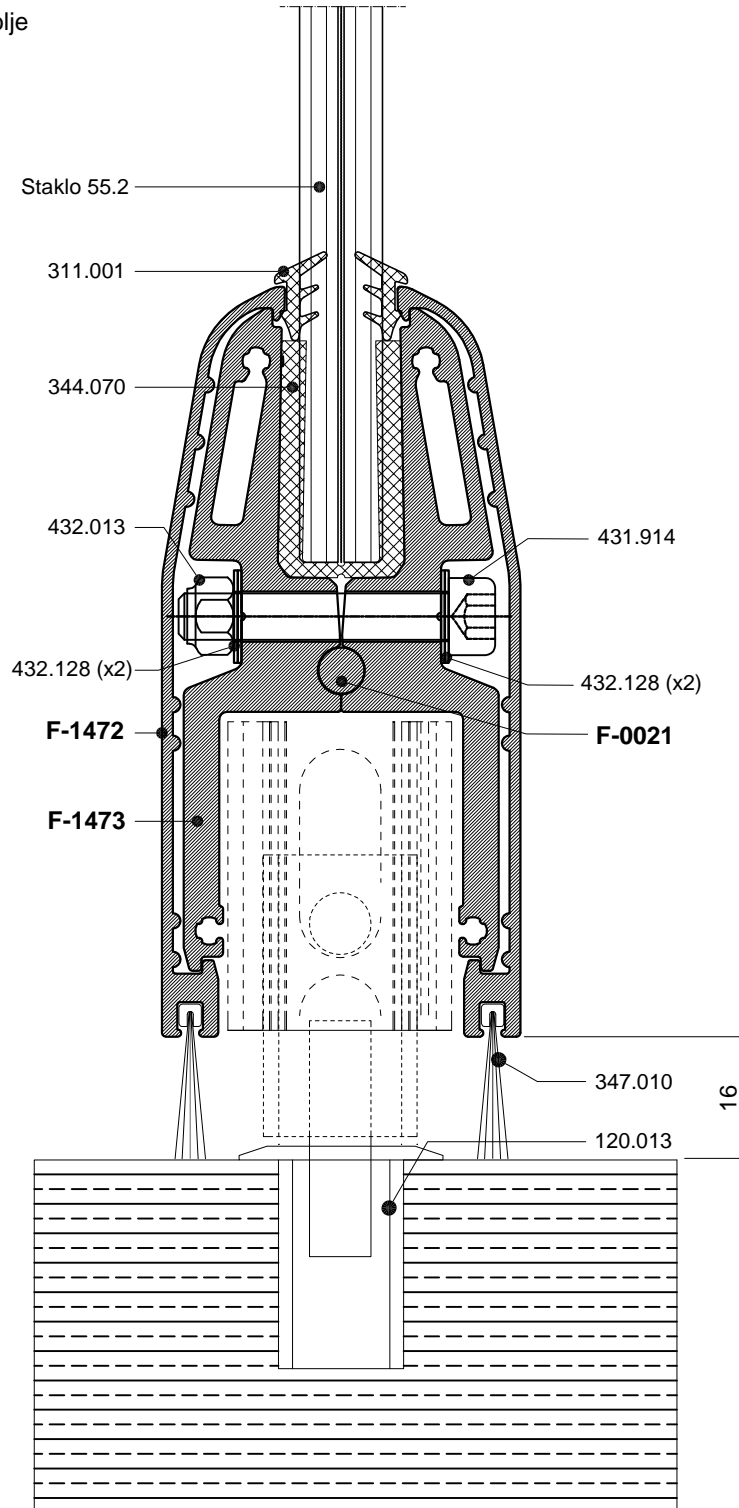

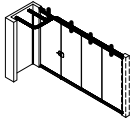

Osiguranje stakla za težine stakla
veće od 70 kg

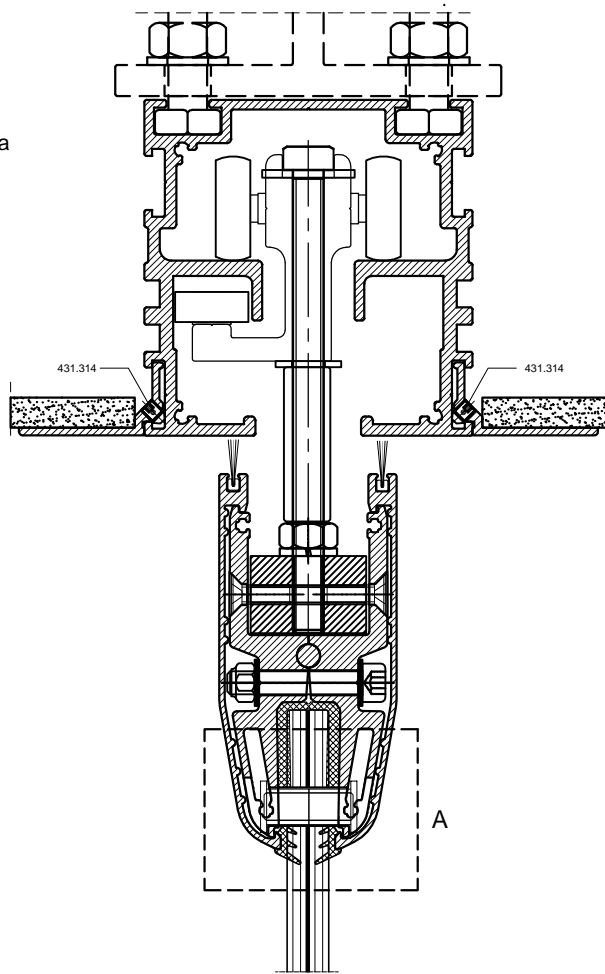

Detalj A

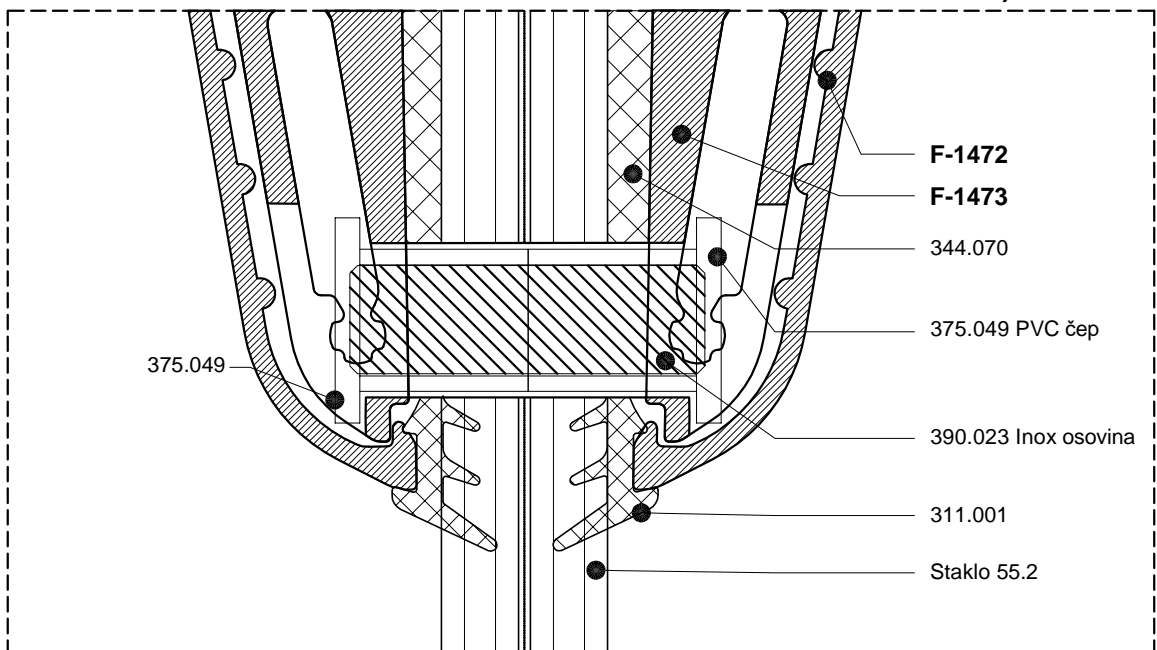

Inox osovina za osiguranje od ispadanja stakla

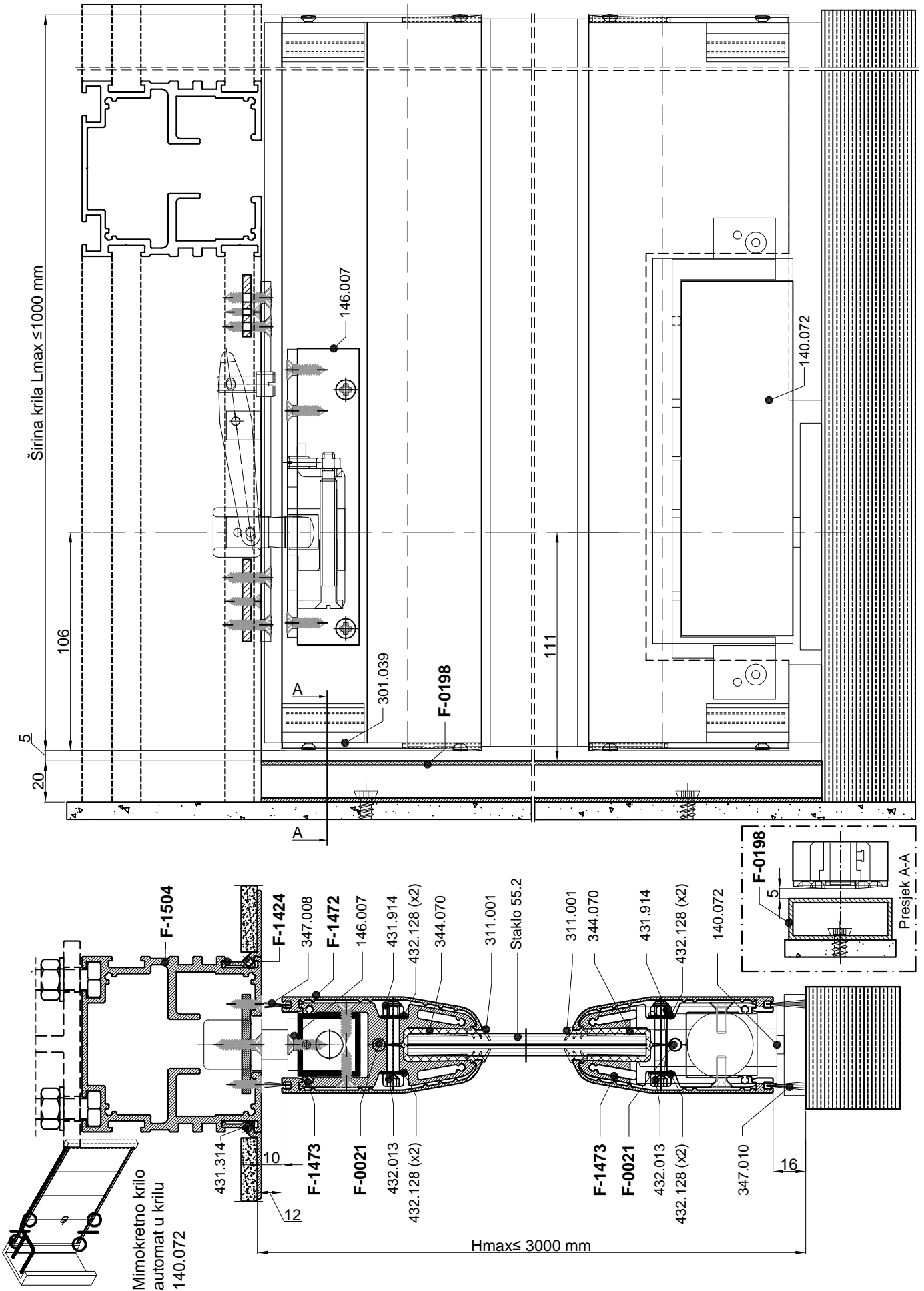

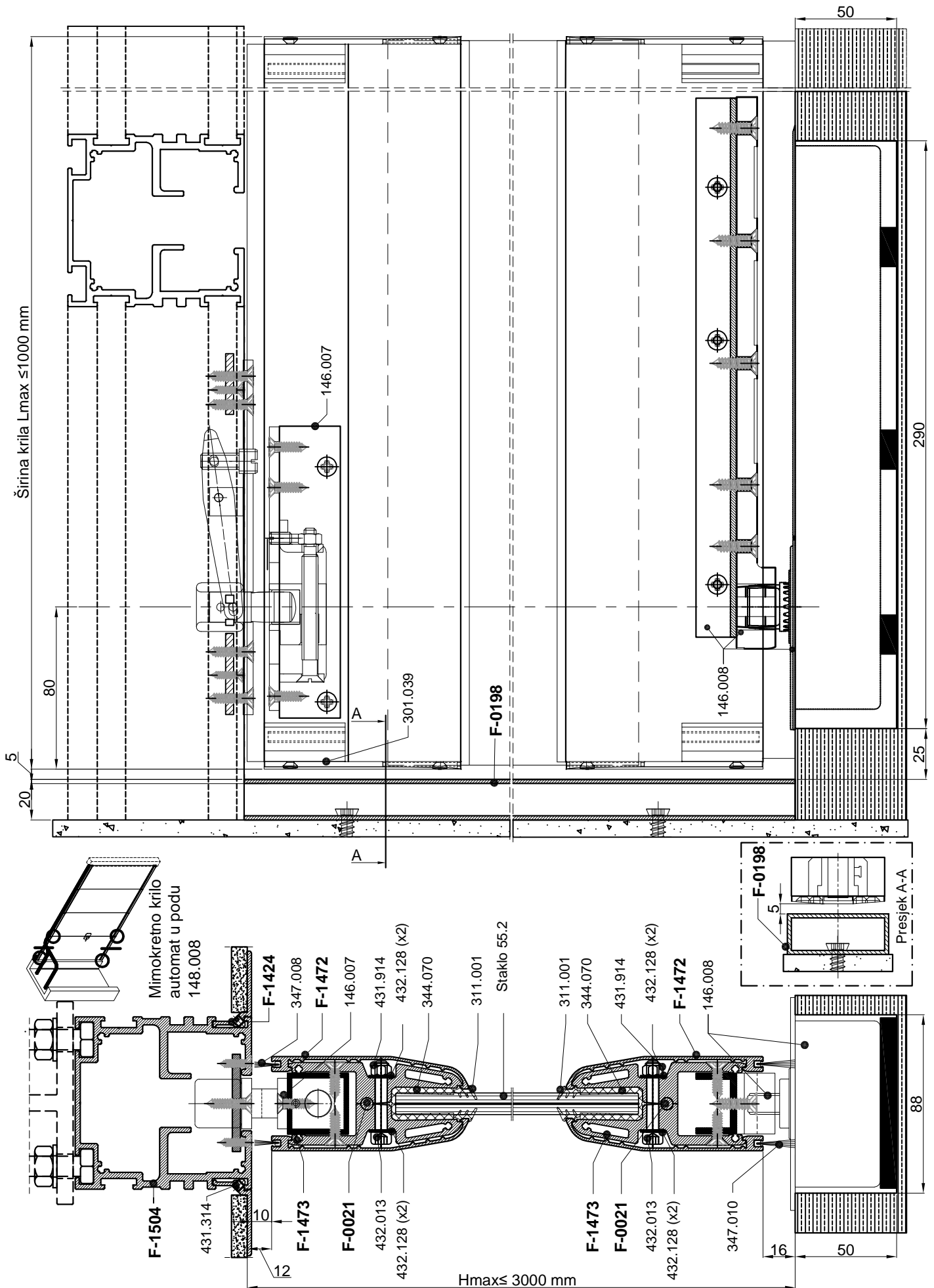

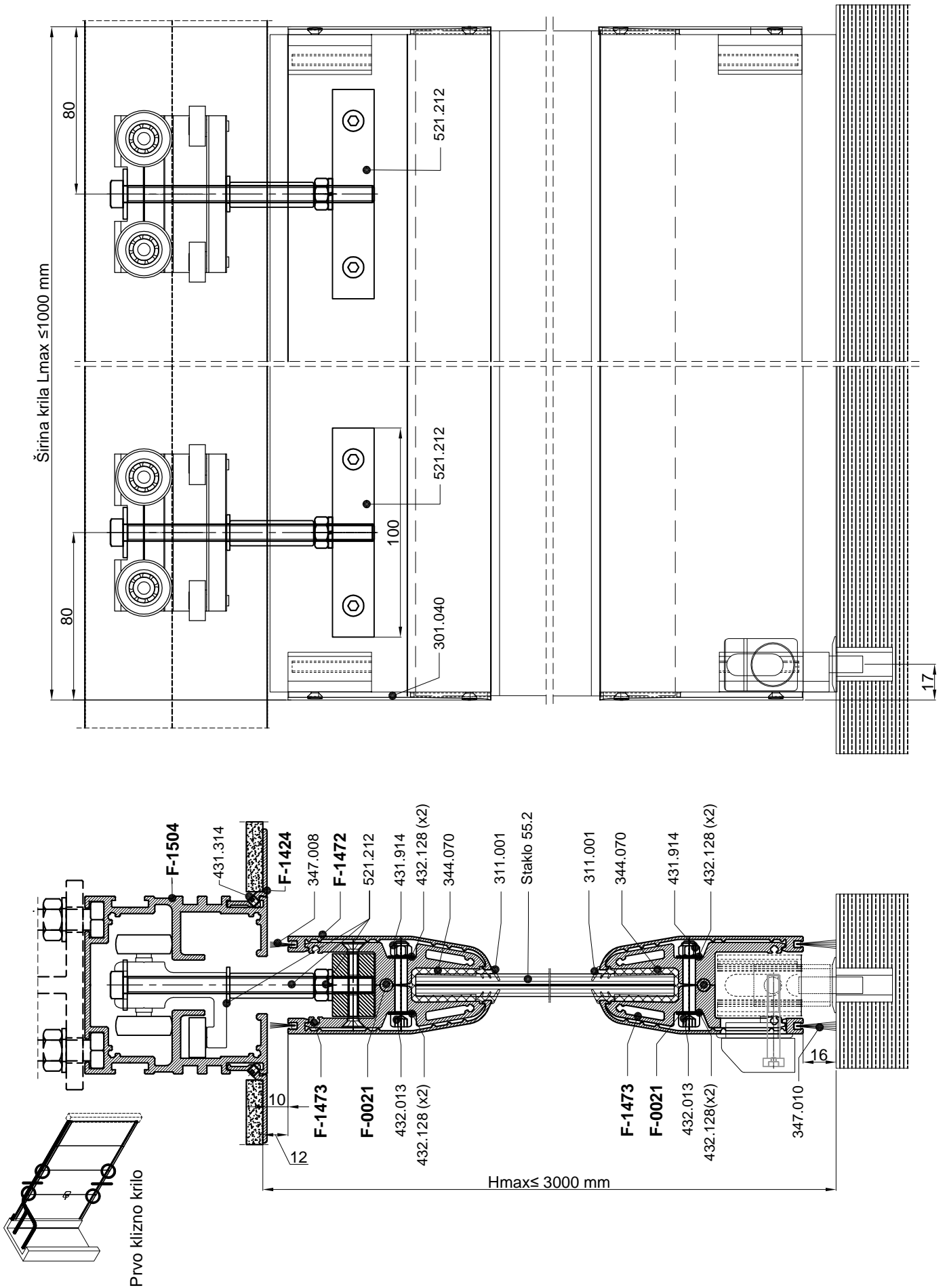

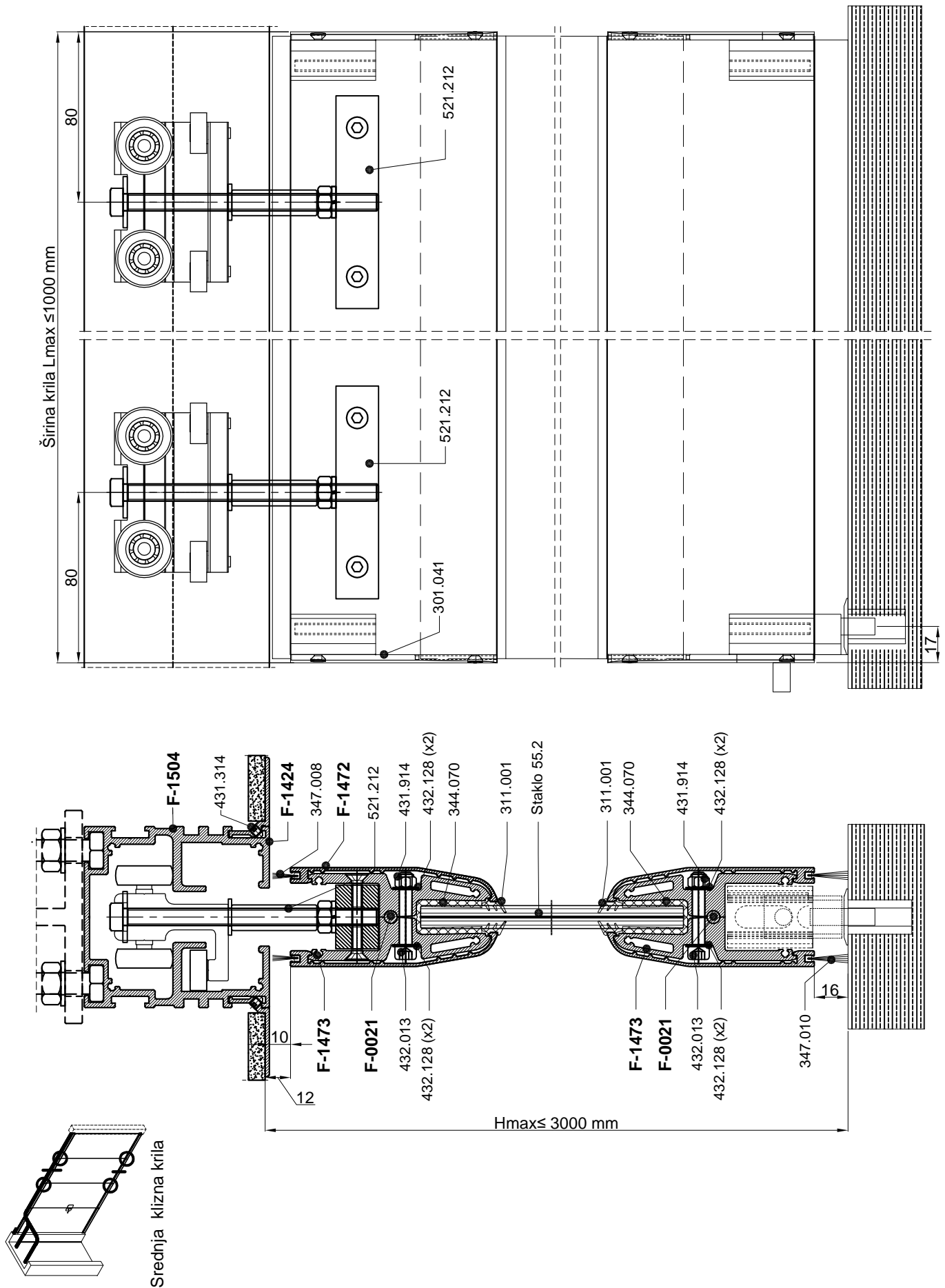

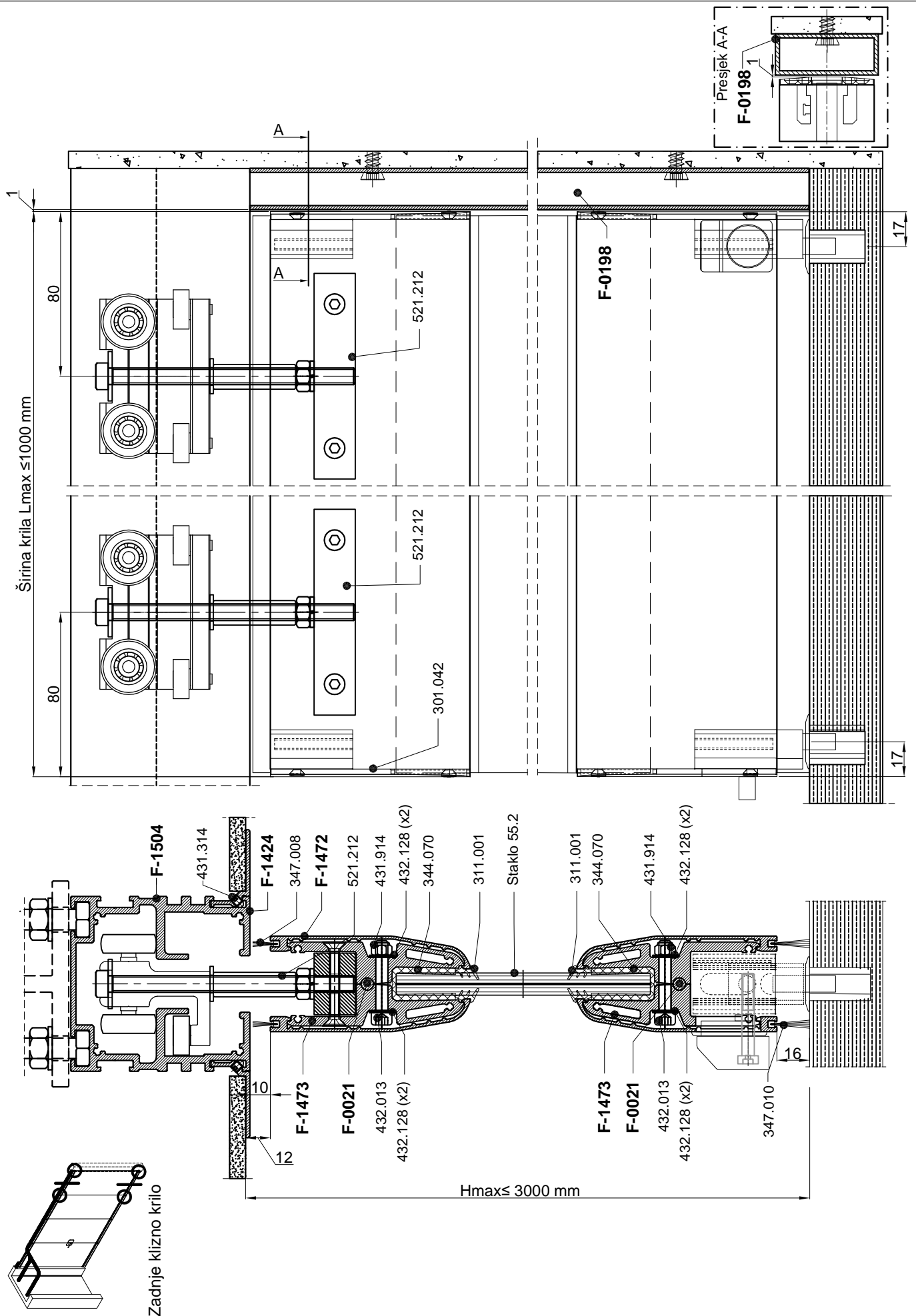

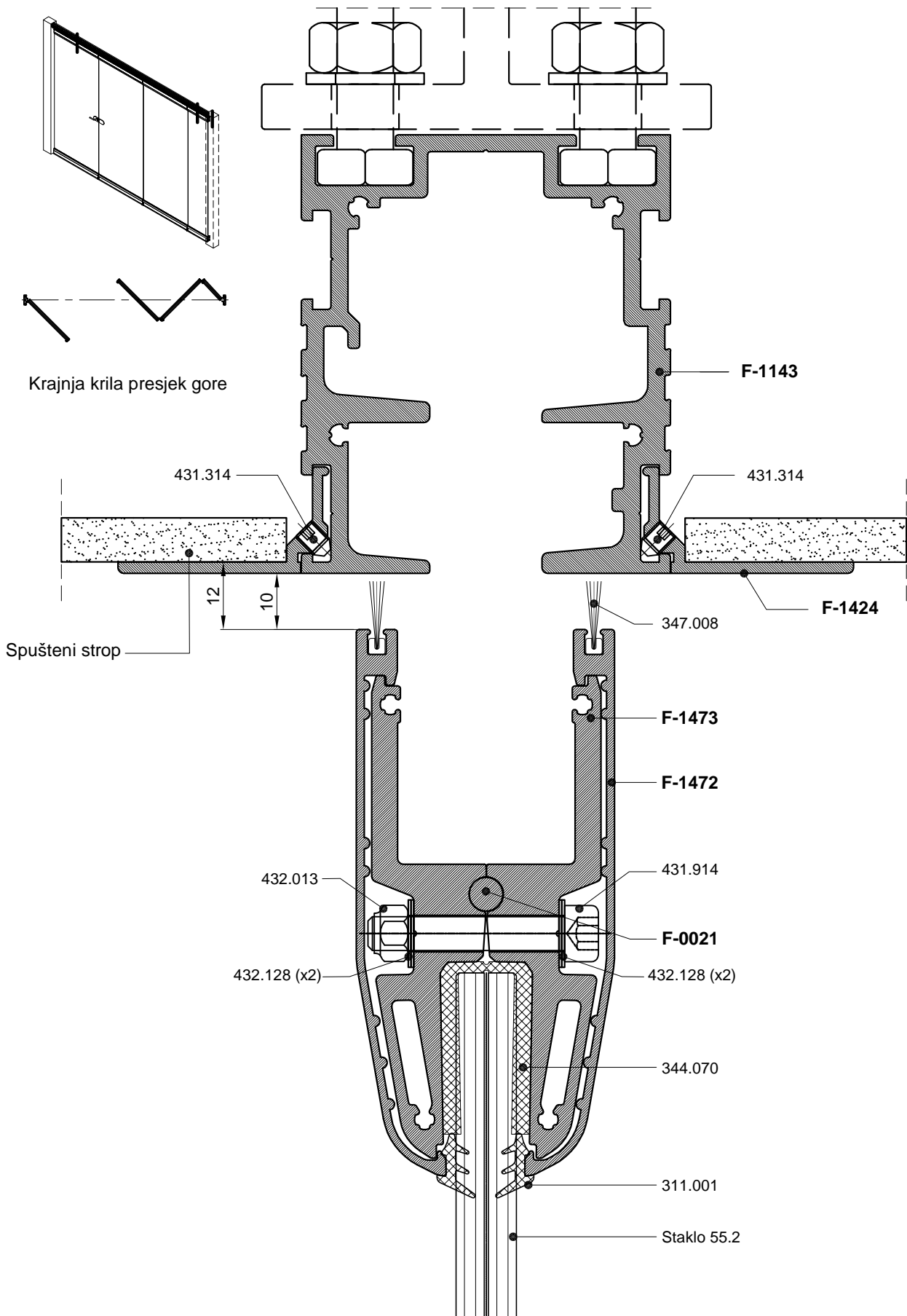

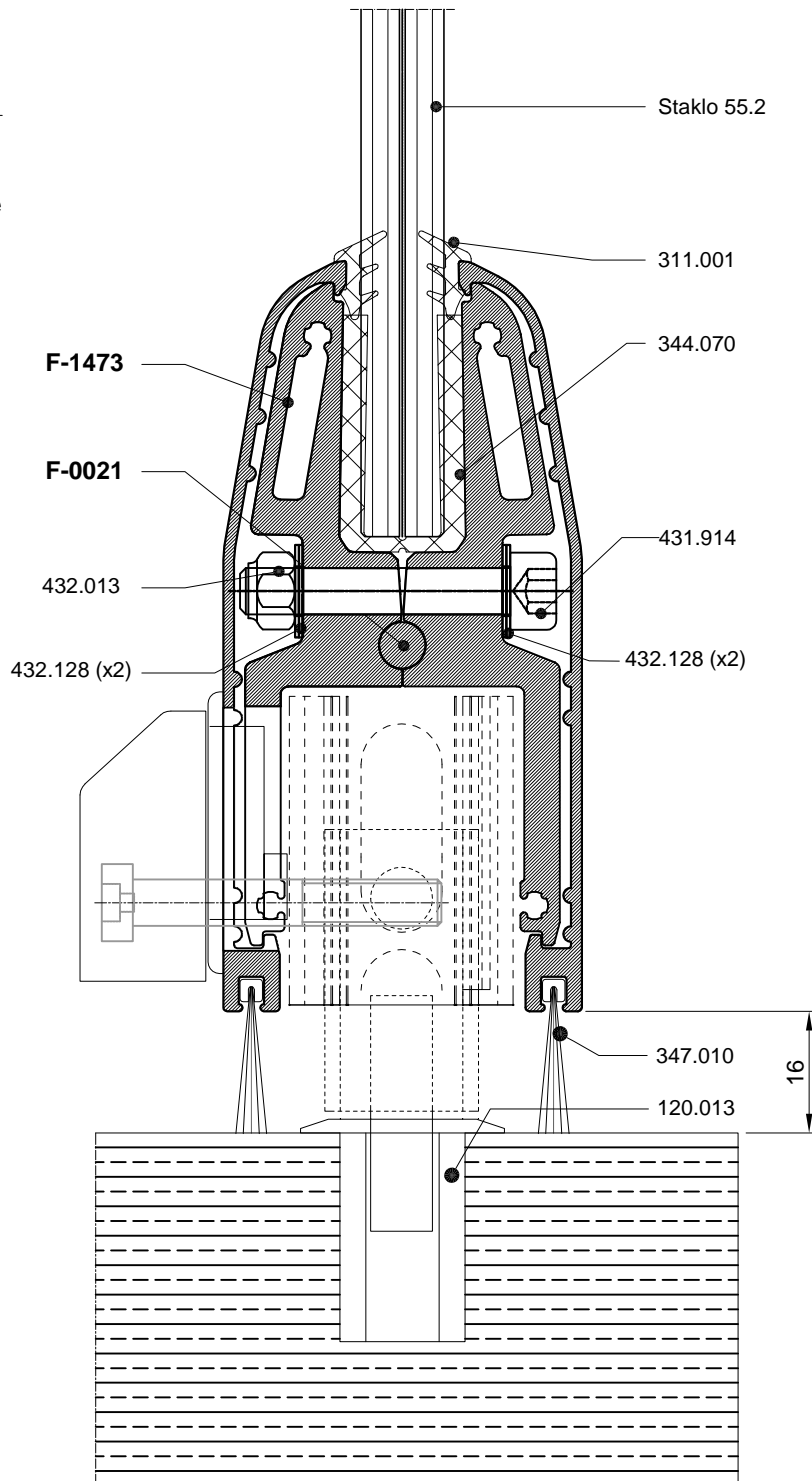
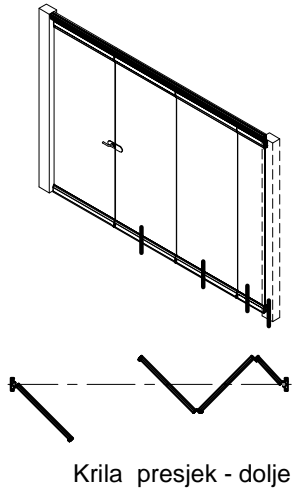

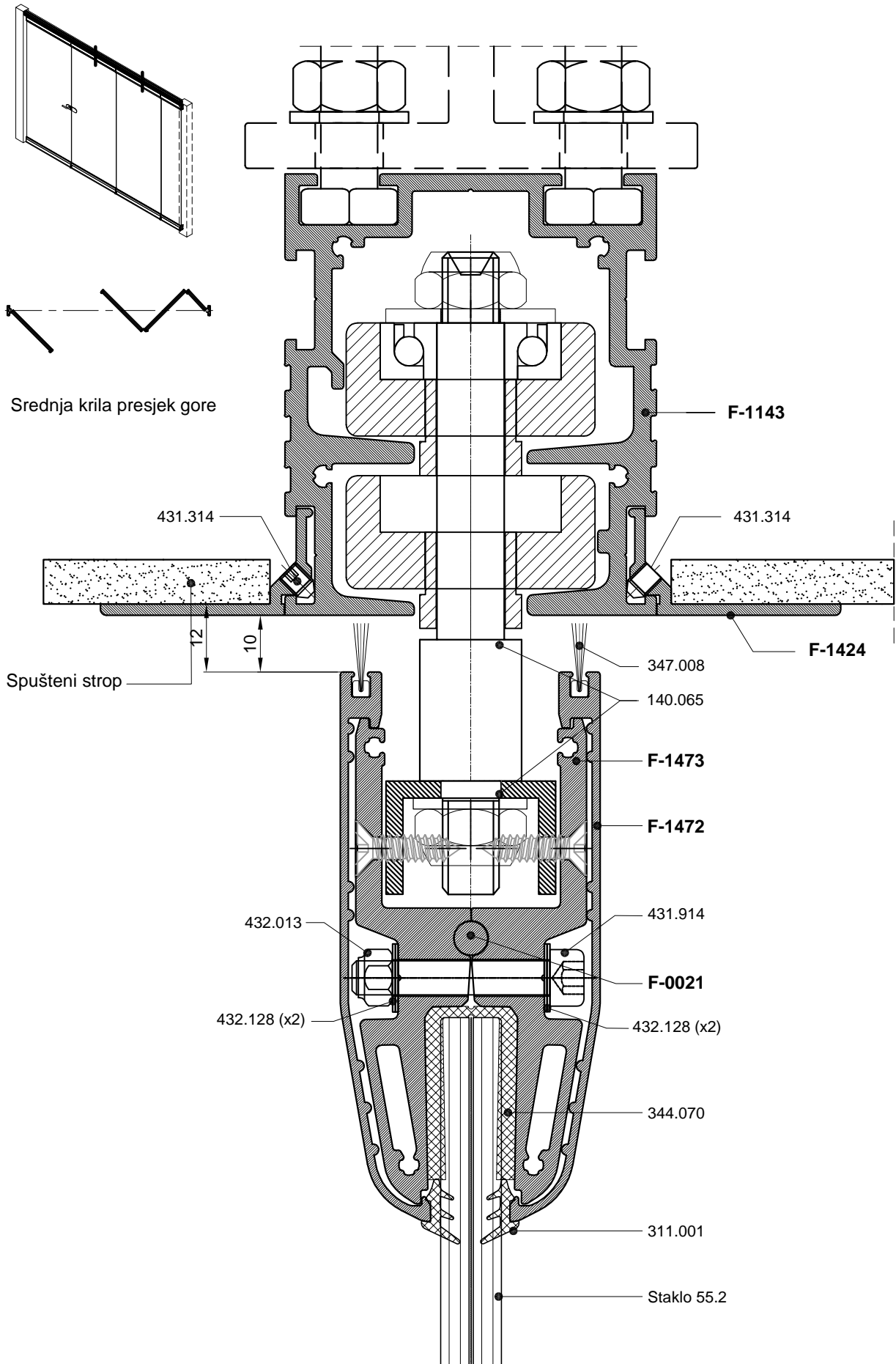

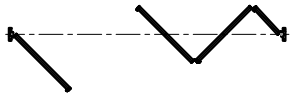
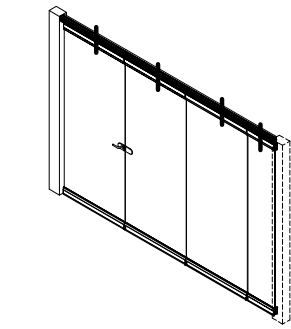

Kрила presjek gore
za krila teža od 70 kg

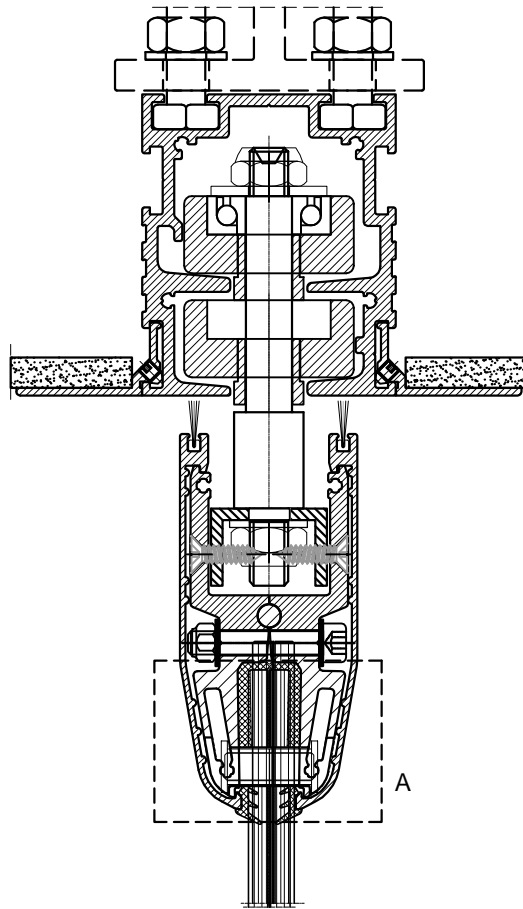

Detalj A

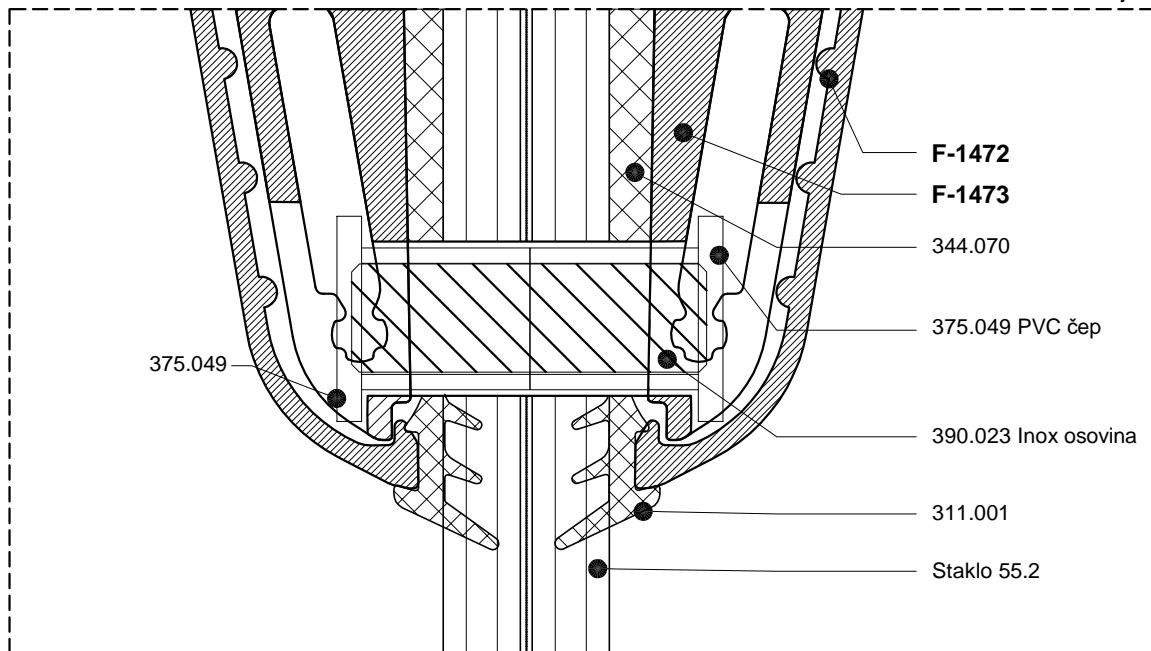

375.049

F-1472

F-1473

344.070

375.049 PVC čep

390.023 Inox osovina

311.001

Staklo 55.2

Inox osovina za osiguranje od ispadanja stakla

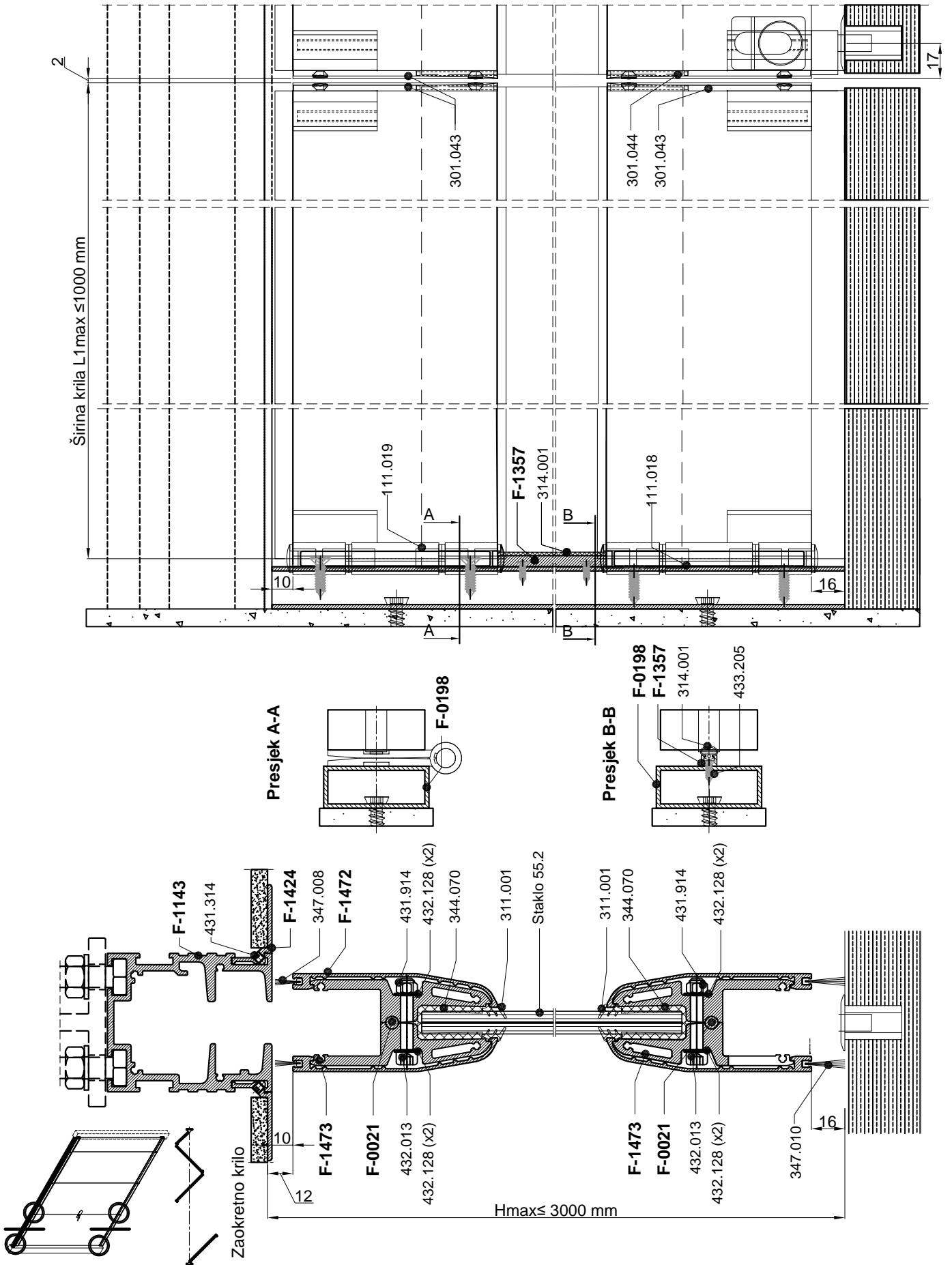

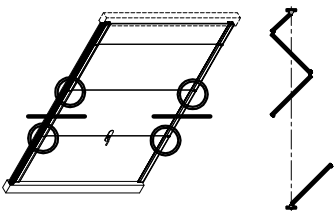
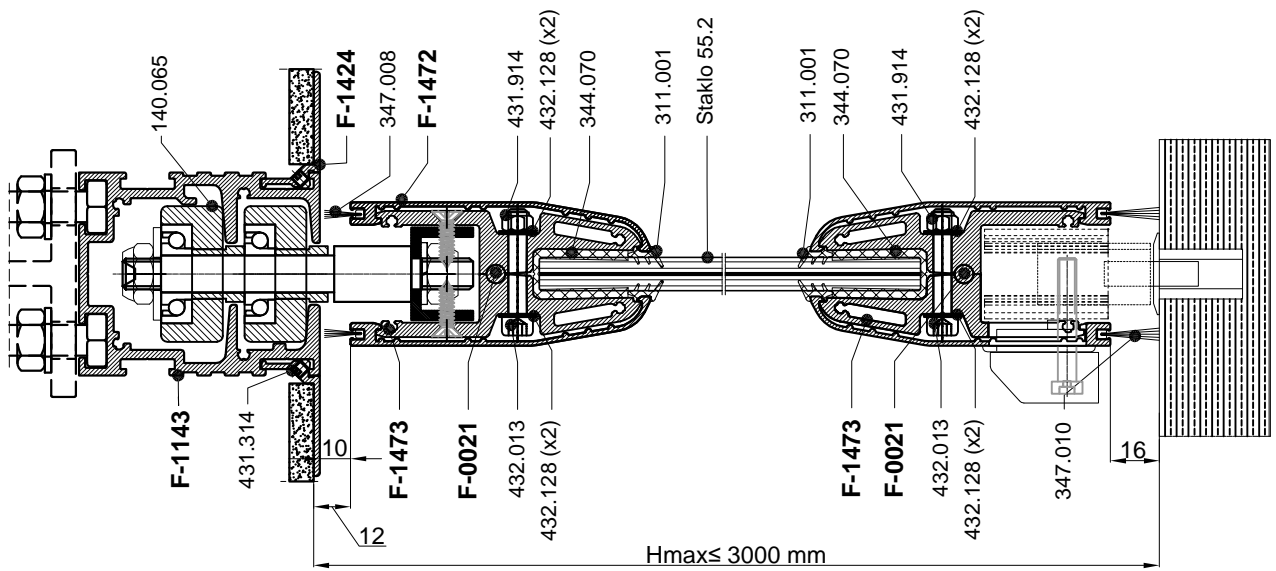
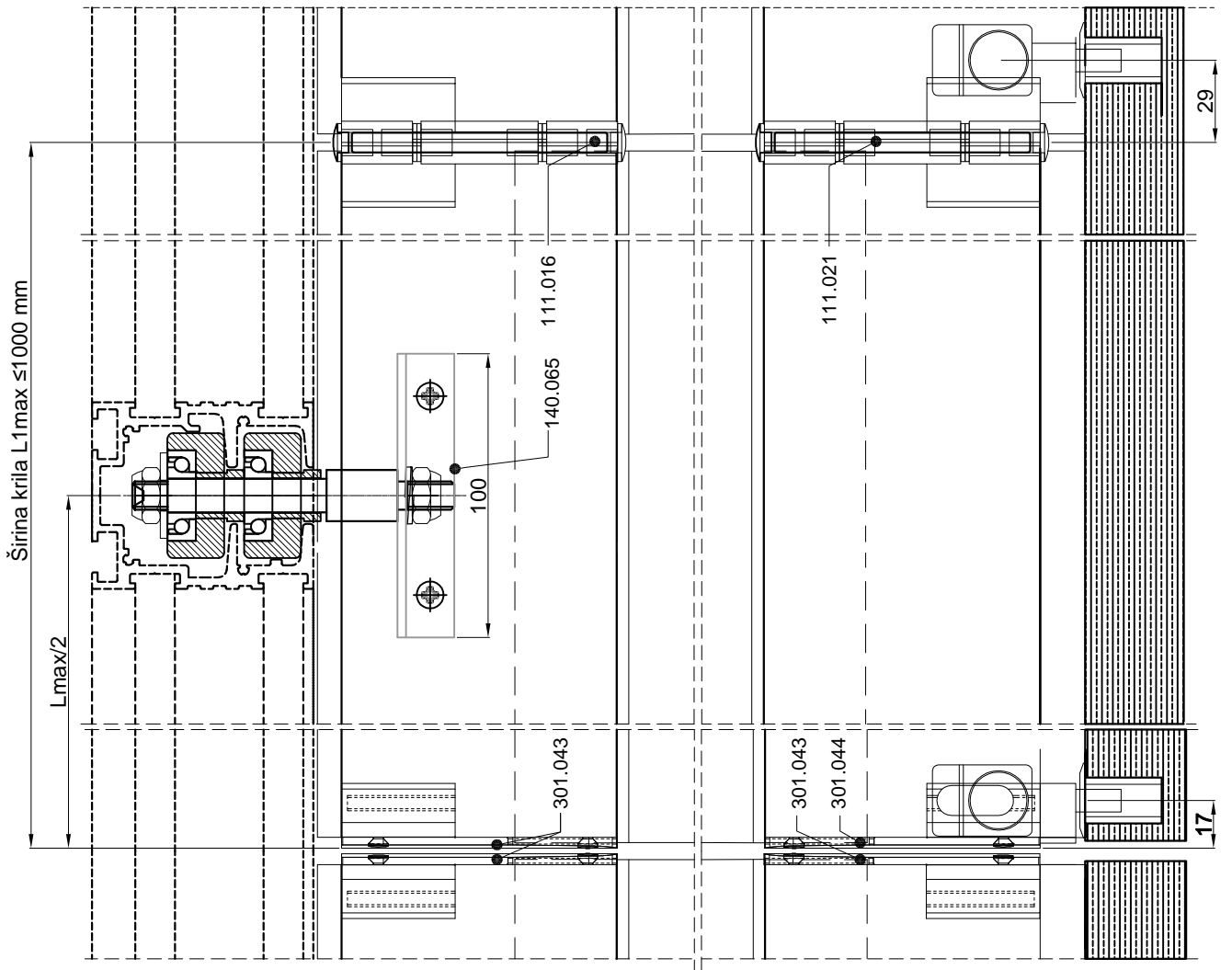

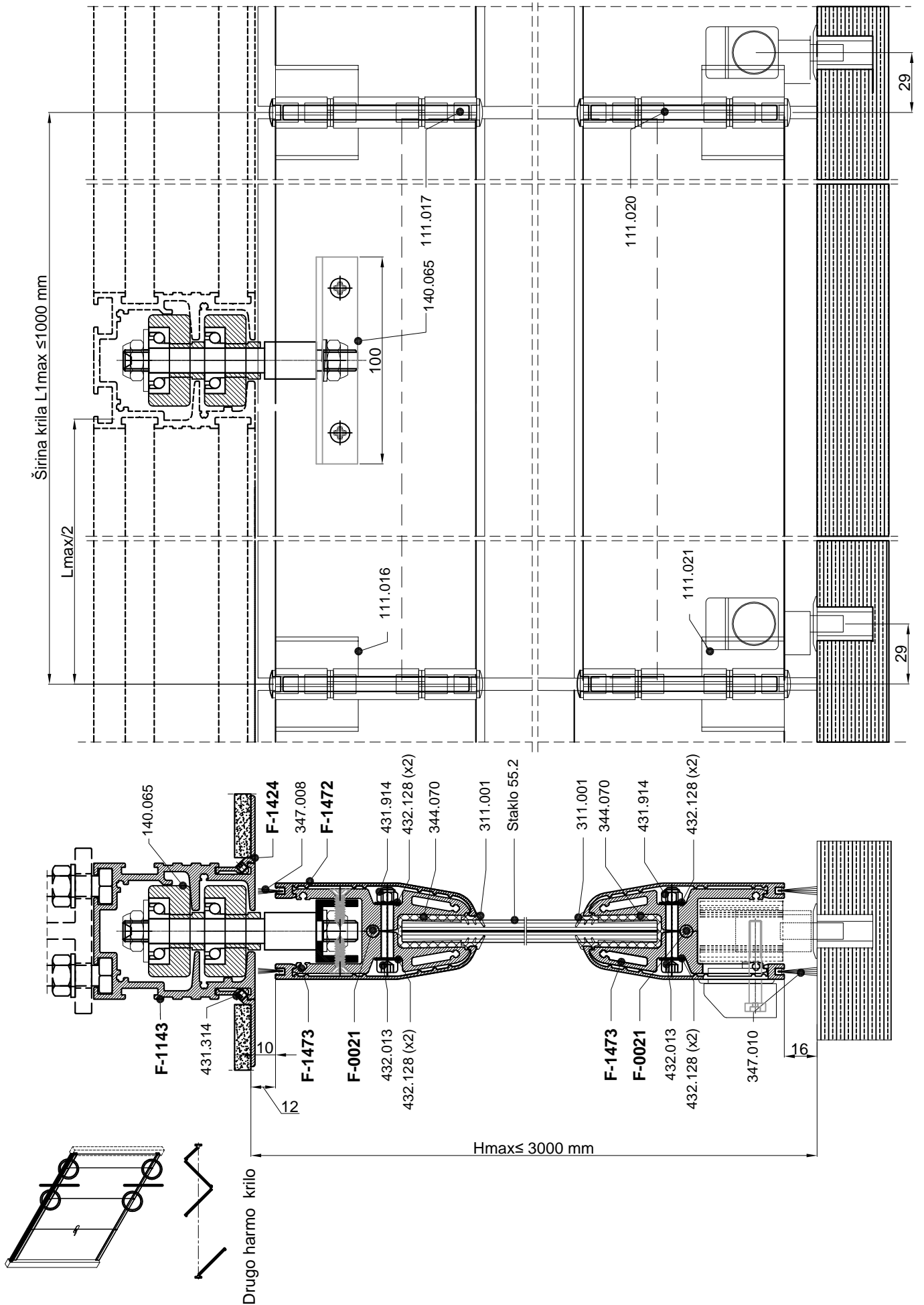

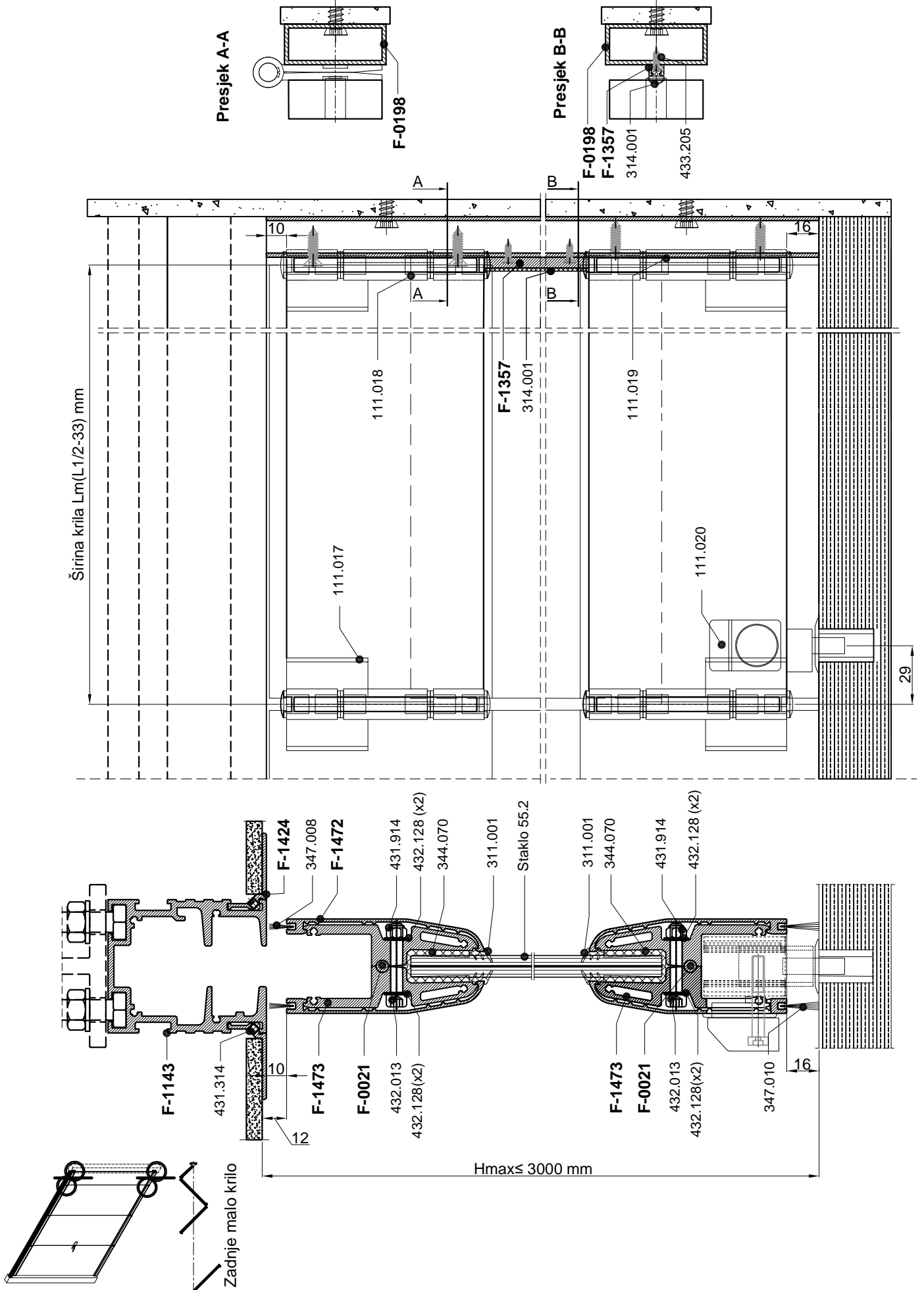

Obrada i montaža

Montaža vodilice na podkonstrukciju

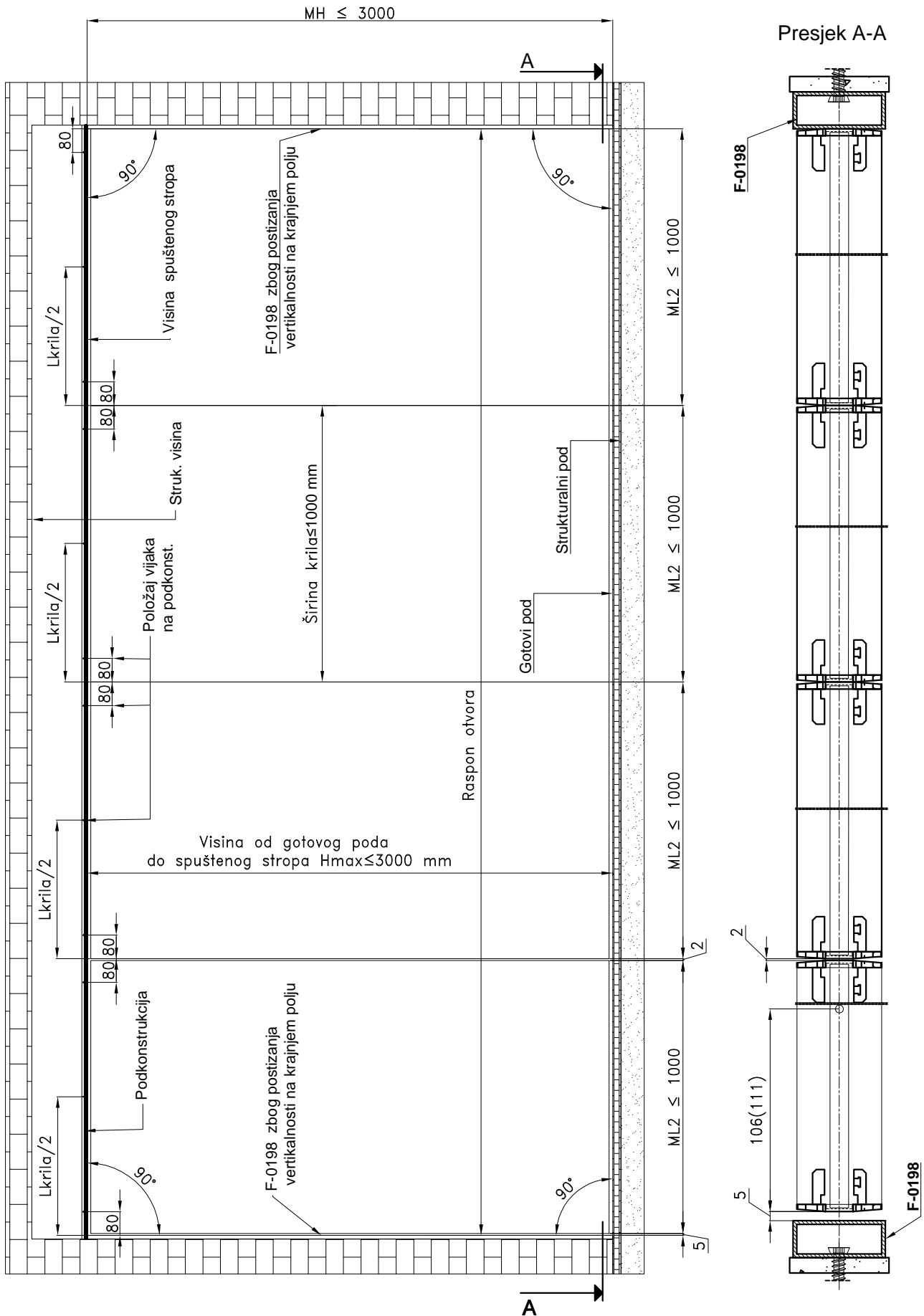

Montaža vodilice na podkonstrukciju

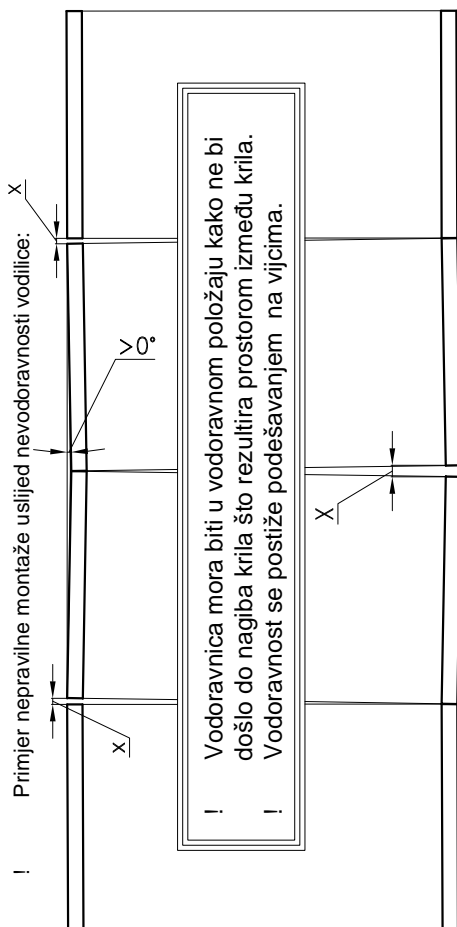

Redoslijed montaže konstrukcije mobilnih stijena:

1. Montaža podkonstrukcije sa vodilicom.
2. Reguliranje vodoravnosti vodilice pomoću laserskog nivelira kako bi krila bila okomita te se adekvatno spojila
3. Postavljanje spuštenog stropa nakon što je vodilica pravilno postavljena
4. Montaža krila u vodilicu

Položaj vijaka koji spajaju vodilicu sa podkonstrukcijom je određen položajem kotačića krila pri zatvorenom položaju zbog efikasnijeg podešavanja vodoravnosti vodilice. Vijci se trebaju nalaziti iznad kotačića i iznad sredine krila.

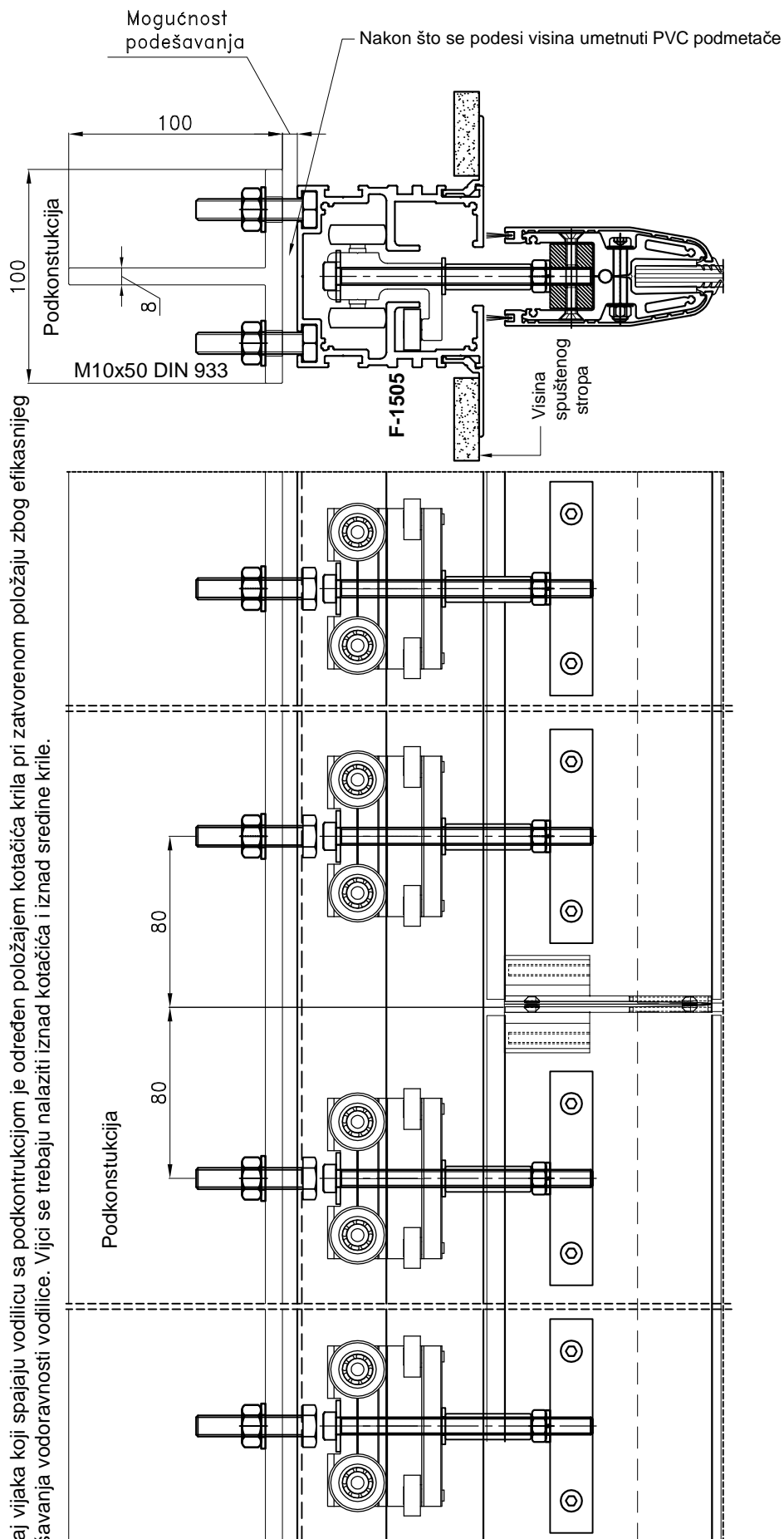

Tipovi otvaranja mobilnih stijena

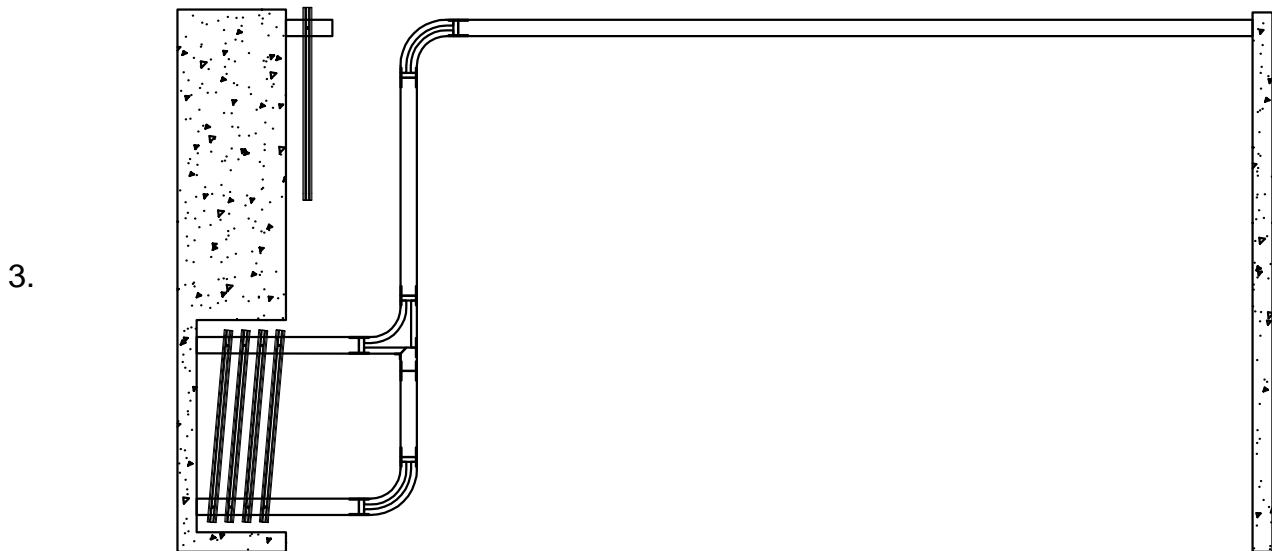

Tipovi otvaranja mobilnih stijena - tip 1

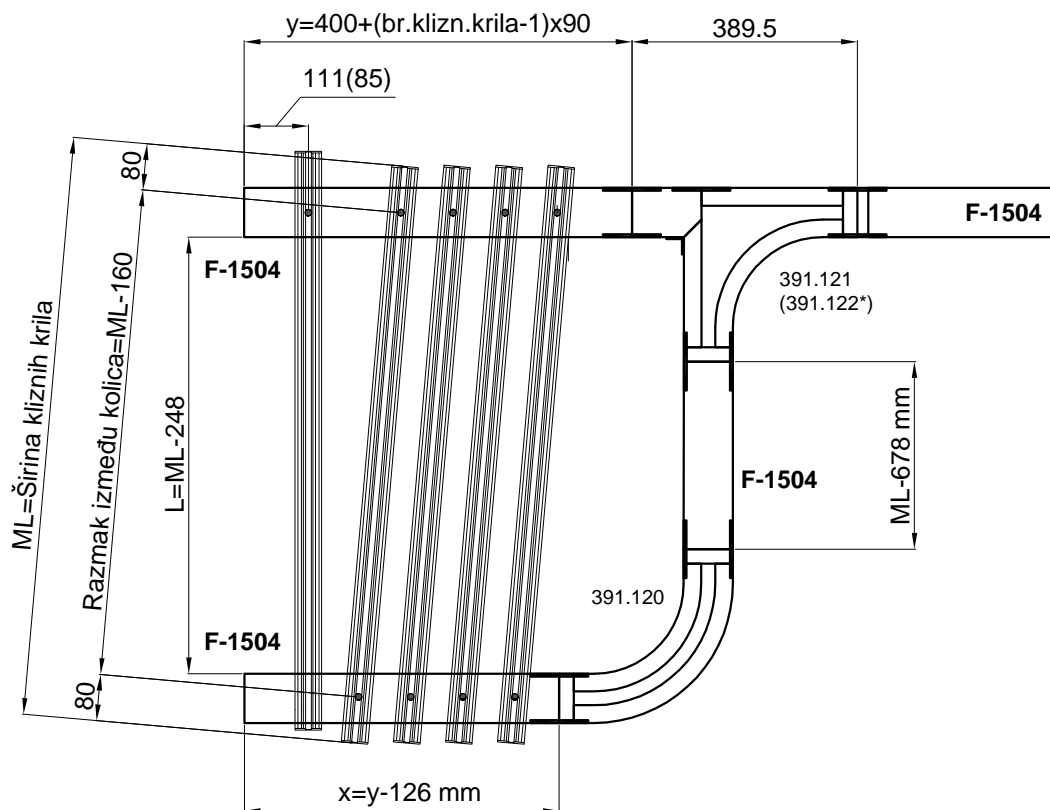
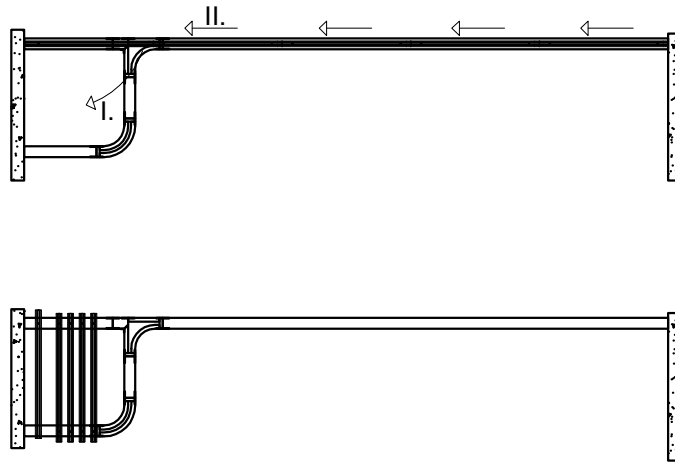

Tipovi otvaranja mobilnih stijena - tip 3

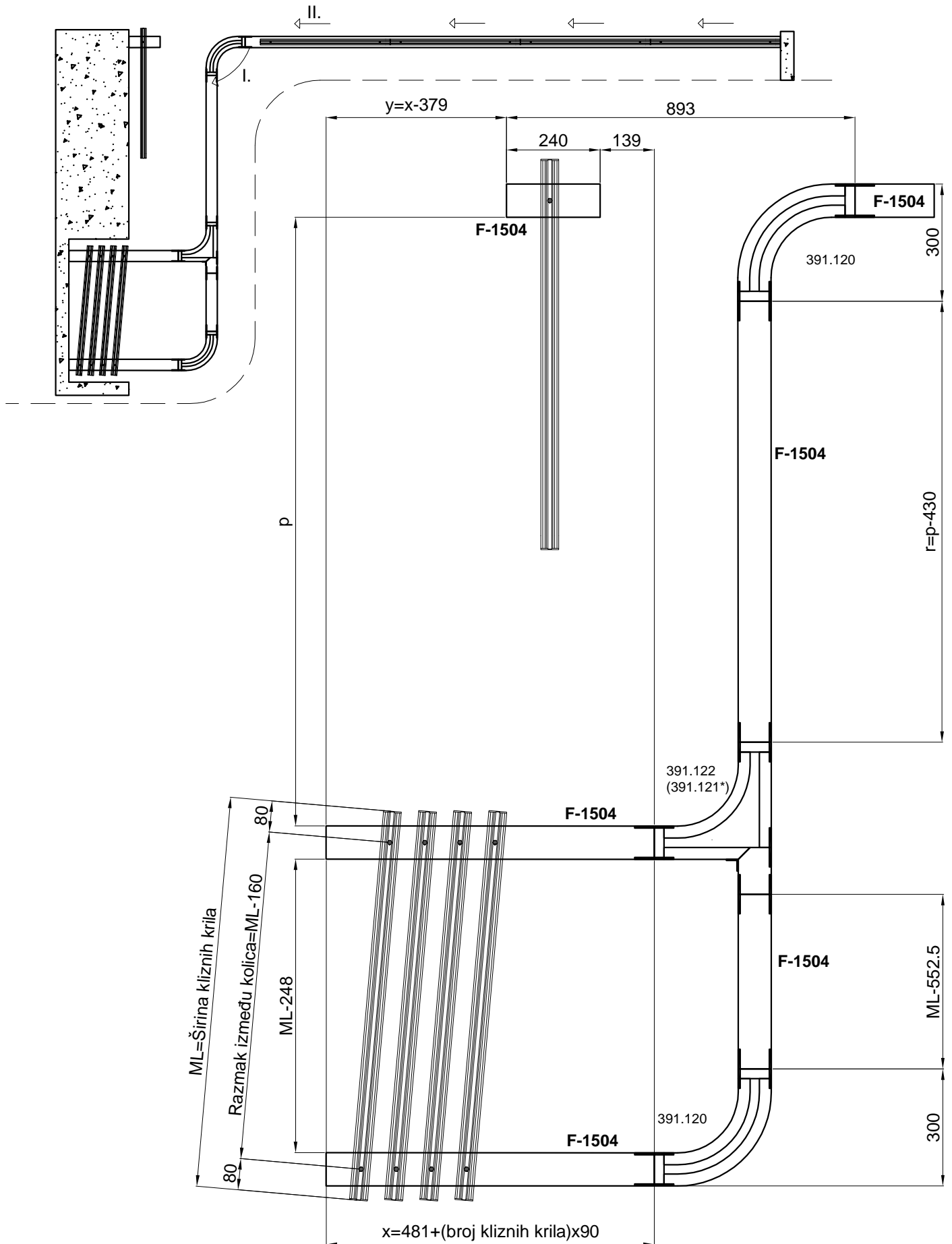

*-suprotna strana

Tipovi otvaranja tip - 4

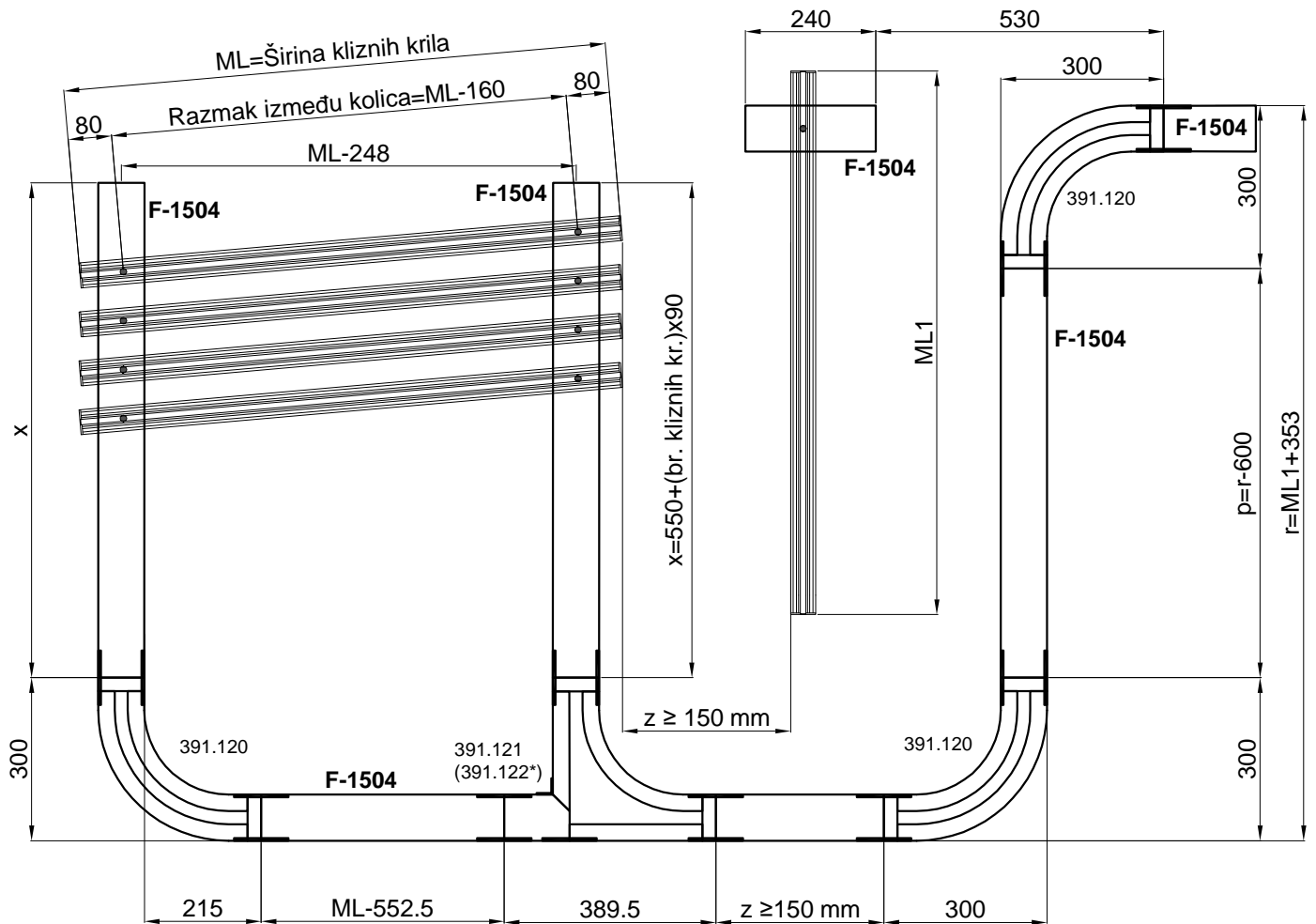
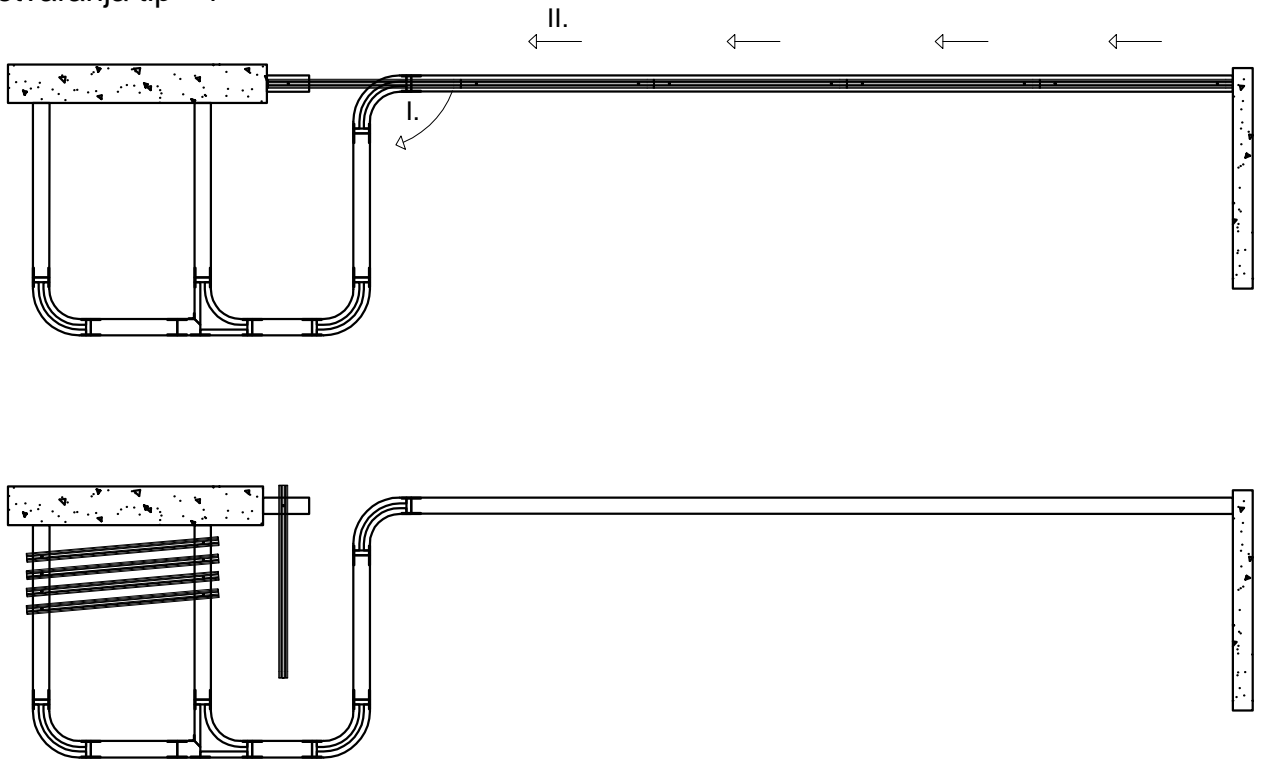

*-suprotna strana

Obrada F-1473 za mimokr. krilo s automatom u podu 146.008 za težinu krila ispod 70 kg

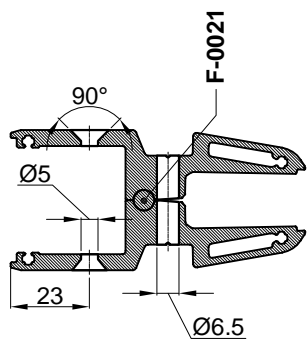
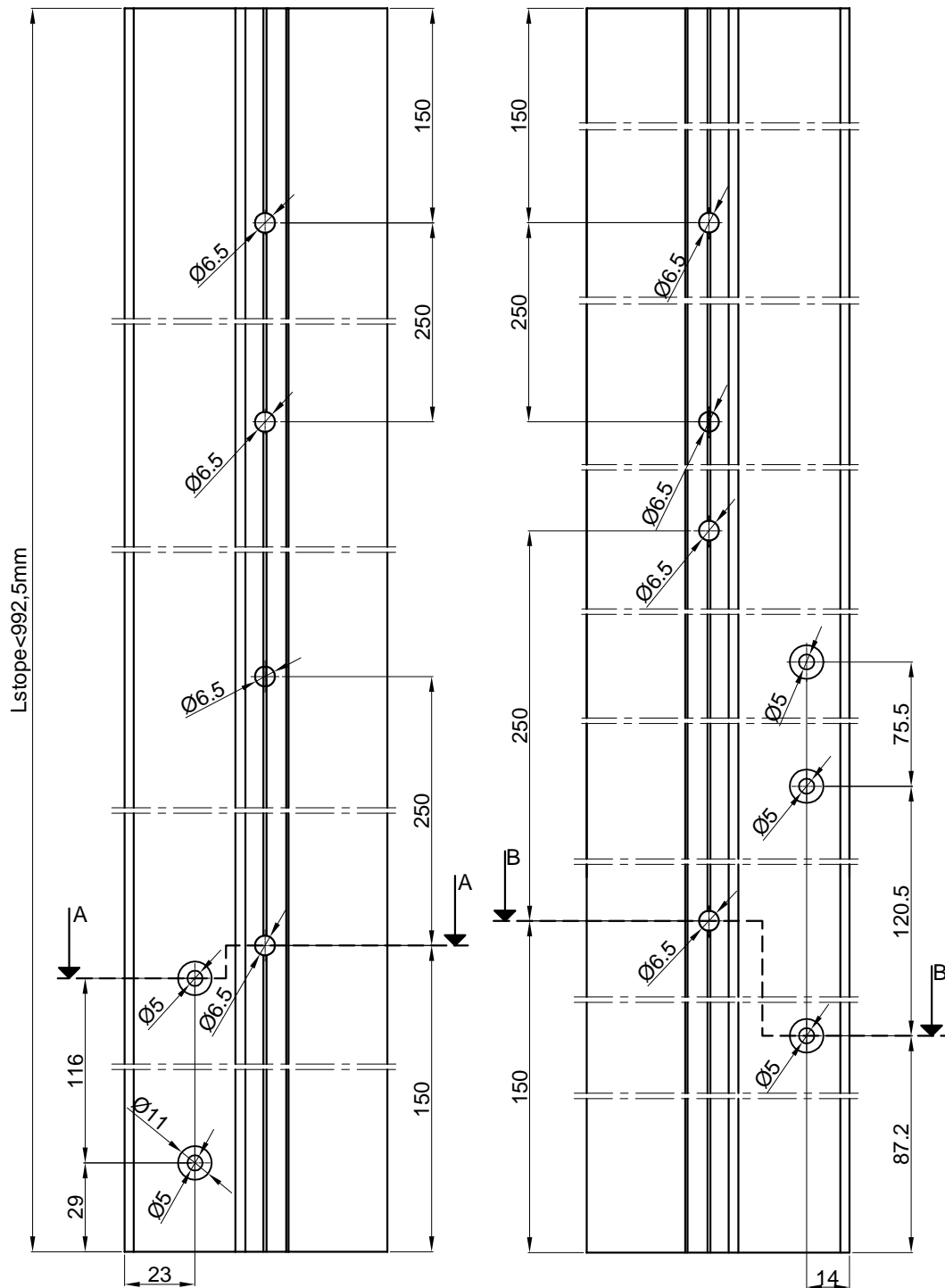

Presjek A-A

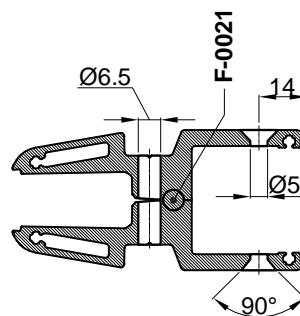

Presjek B-B

Obrada F-1472;F-1473 za mimok. krilo sa automatom u krilu 140.072 za težinu krila ispod 70 kg

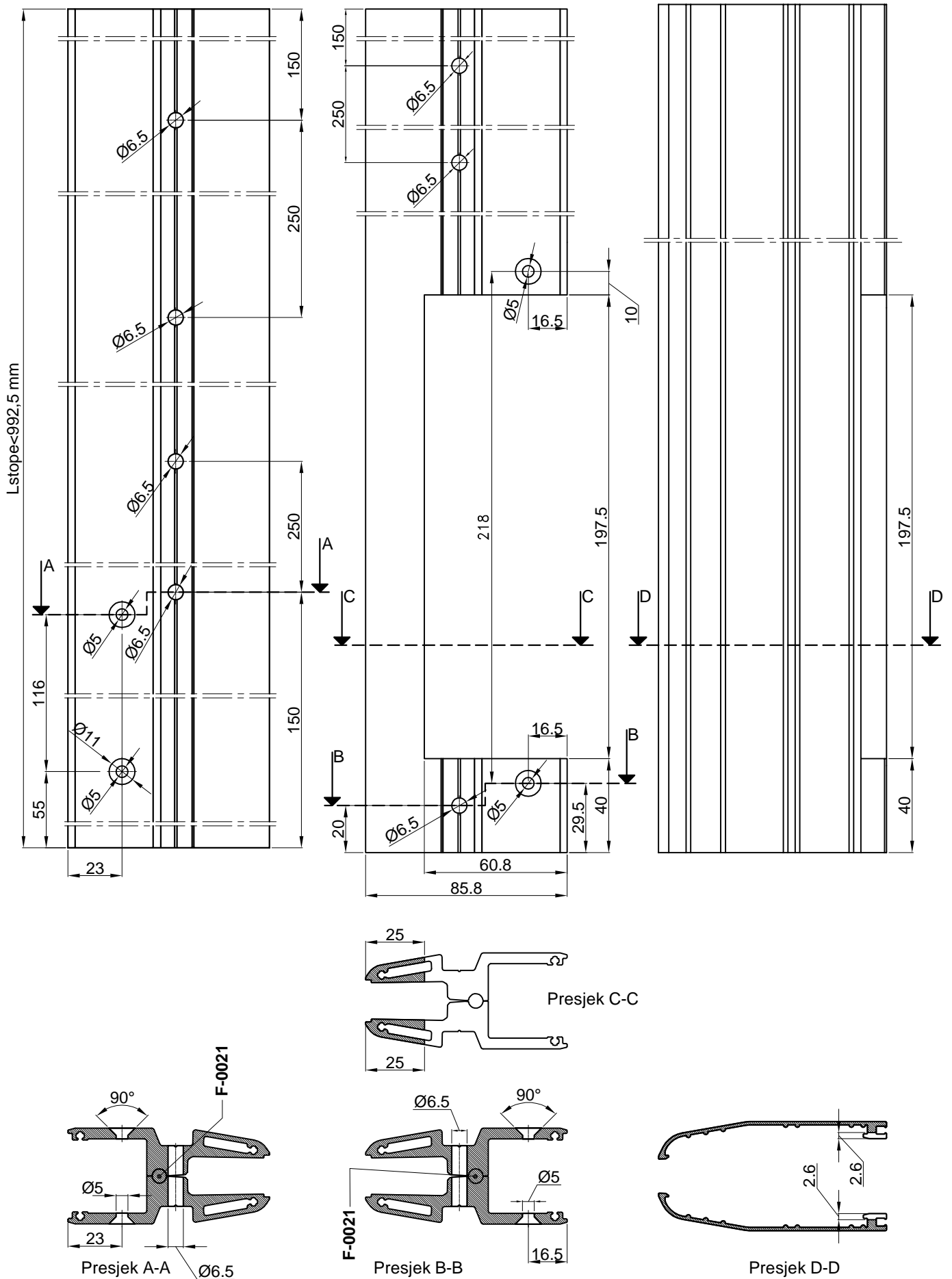

Obrada profila F-1473 za prvo klizno krilo za težinu krila ispod 70 kg

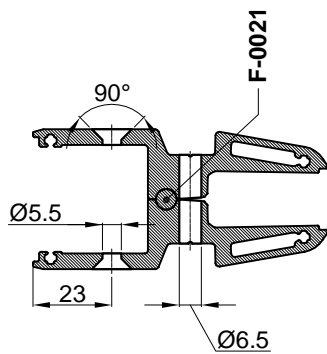
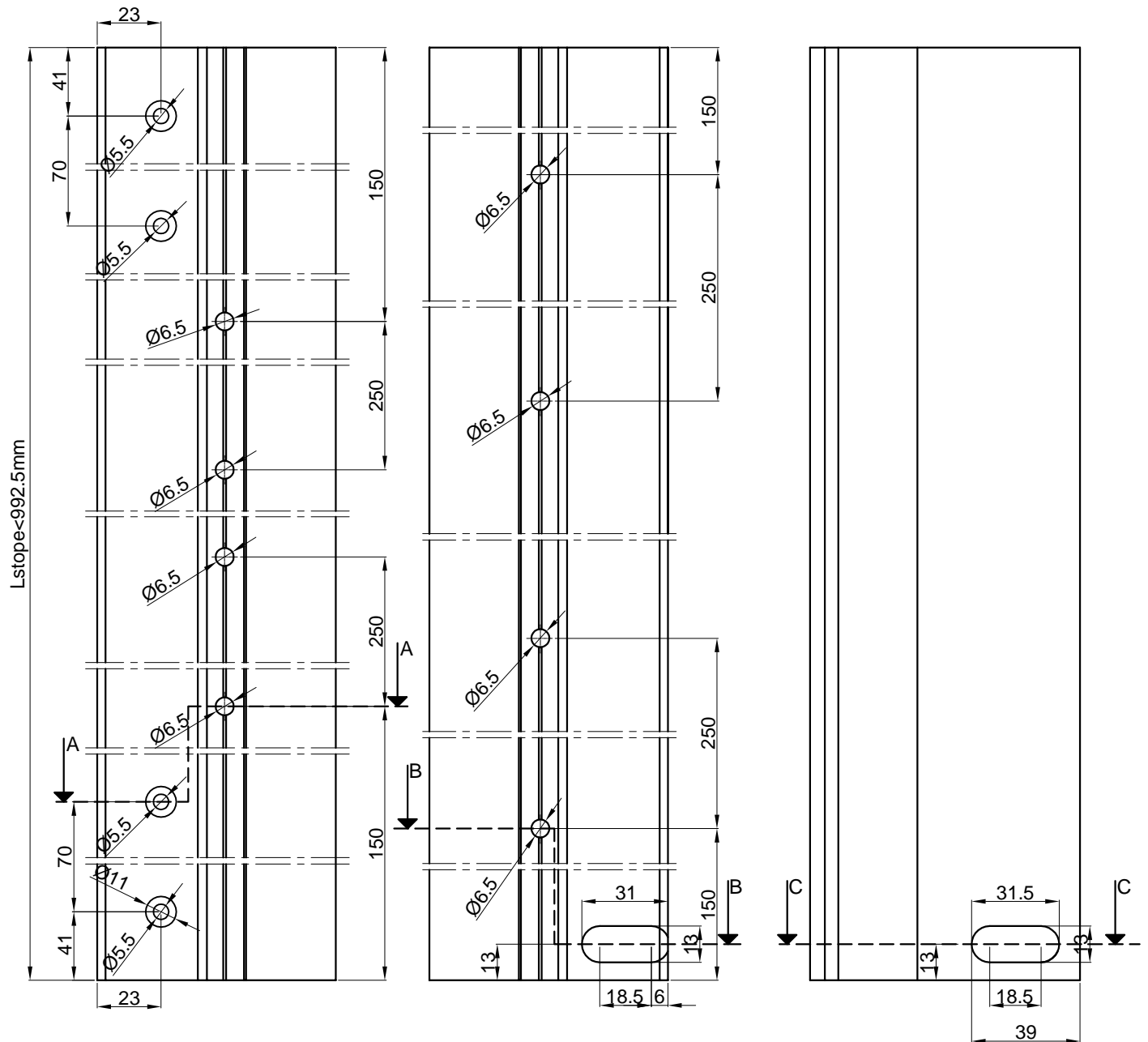

Presjek A-A

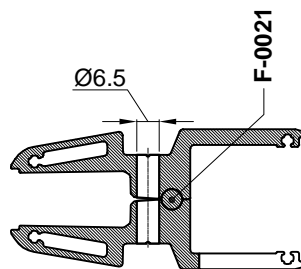

Presjek B-B

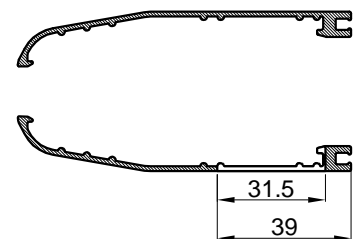

Presjek C-C

Obrada profila F-1473 za srednje klizno krilo za težinu krila ispod 70 kg

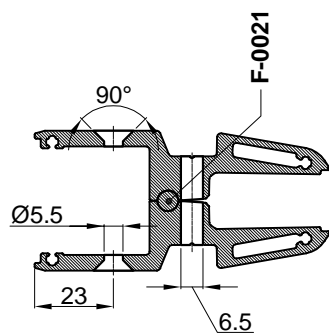
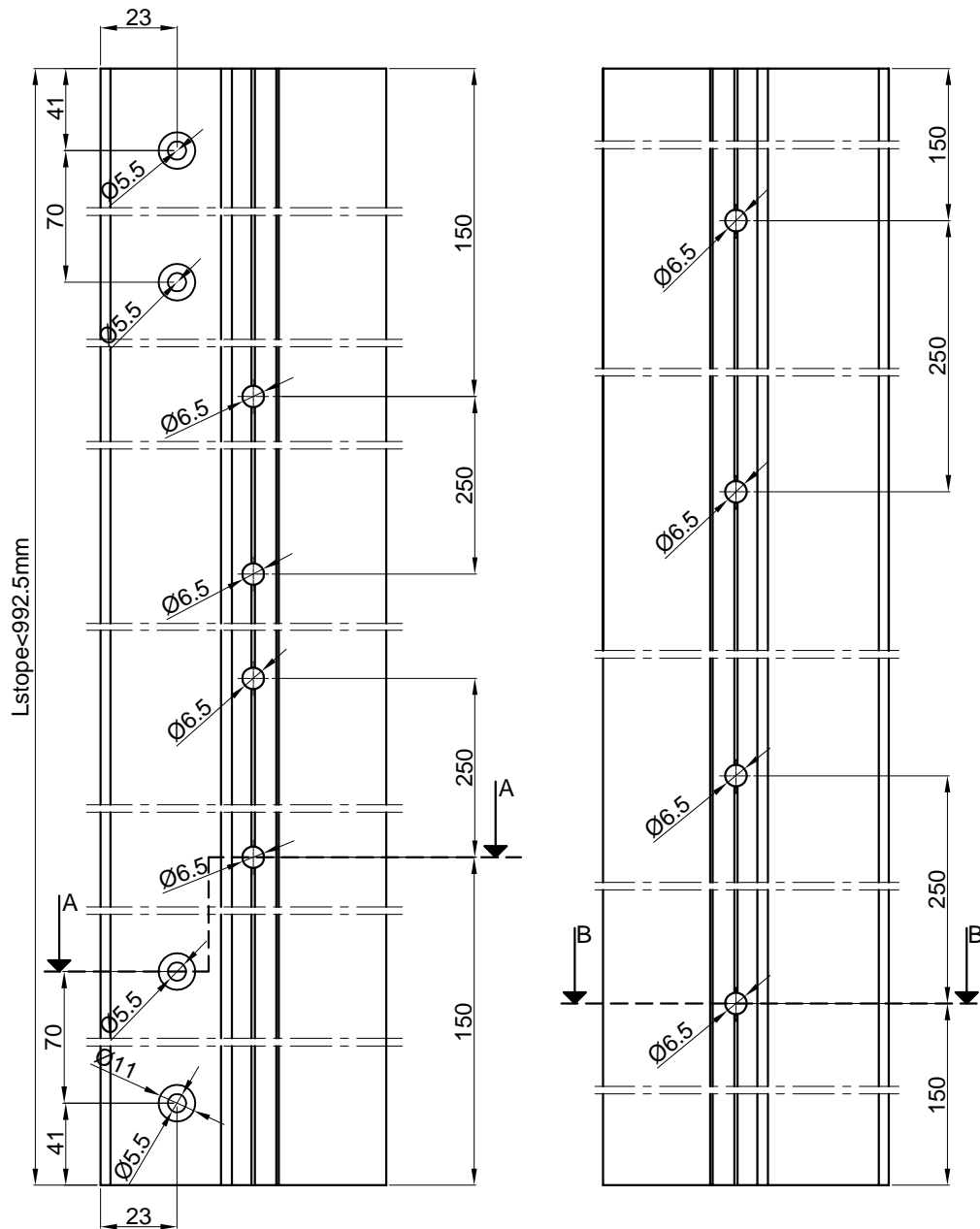

Presjek A-A

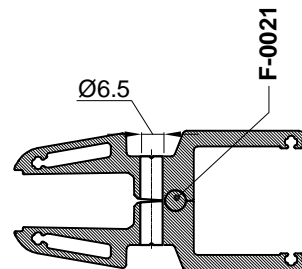

Presjek B-B

Obrada profila F-1473 za zadnje klizno krilo za težinu krila ispod 70 kg

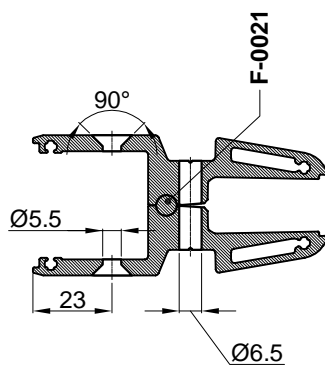
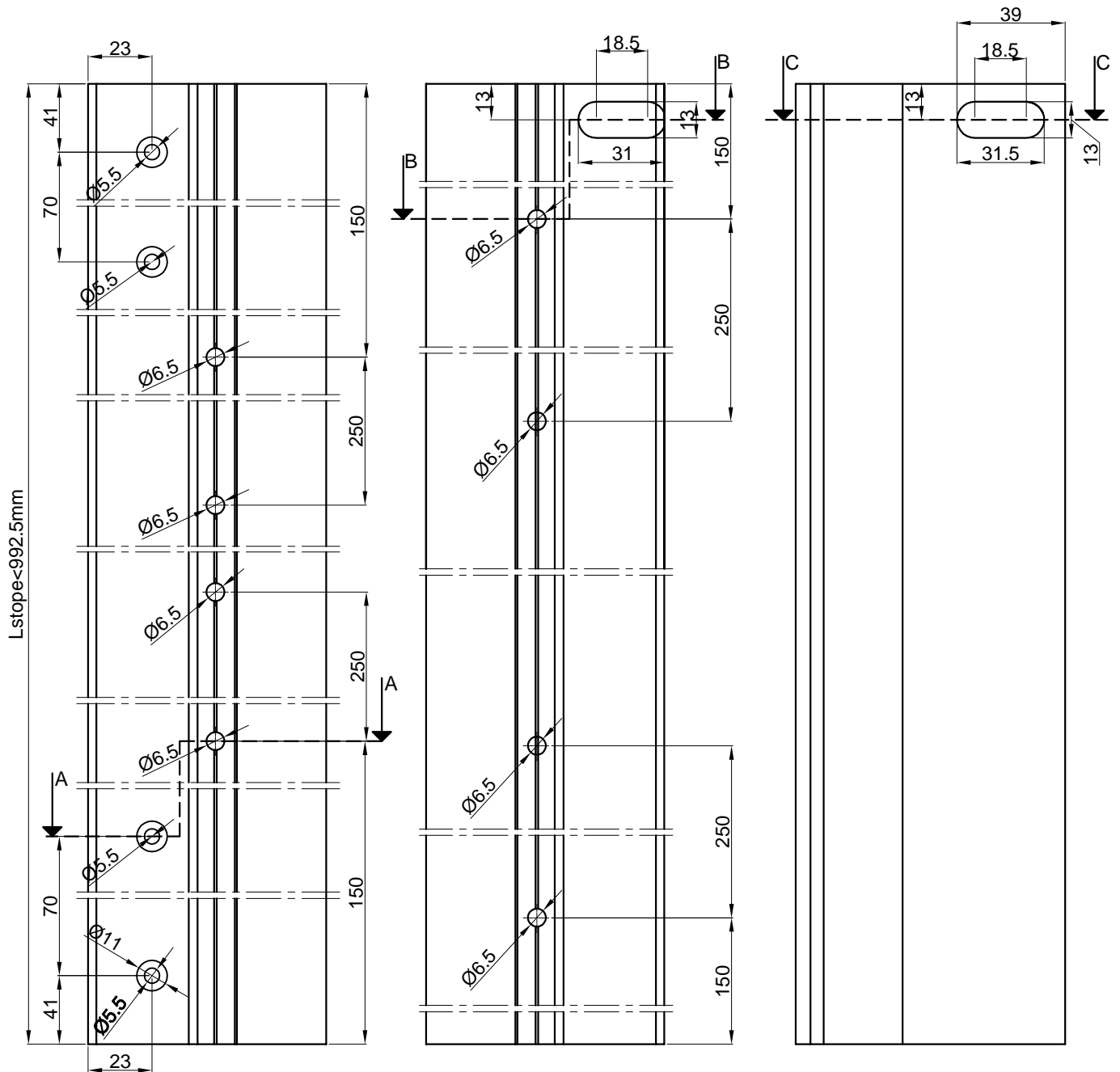

Presjek A-A

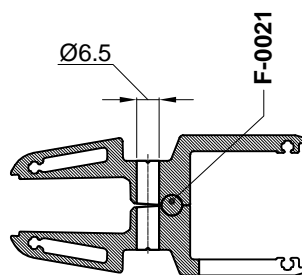

Presjek B-B

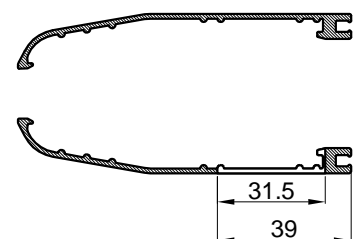

Presjek C-C

Obrada F-1472;F-1473 za mimok. krilo sa automatom u krilu 140.072 za težinu krila iznad 70 kg

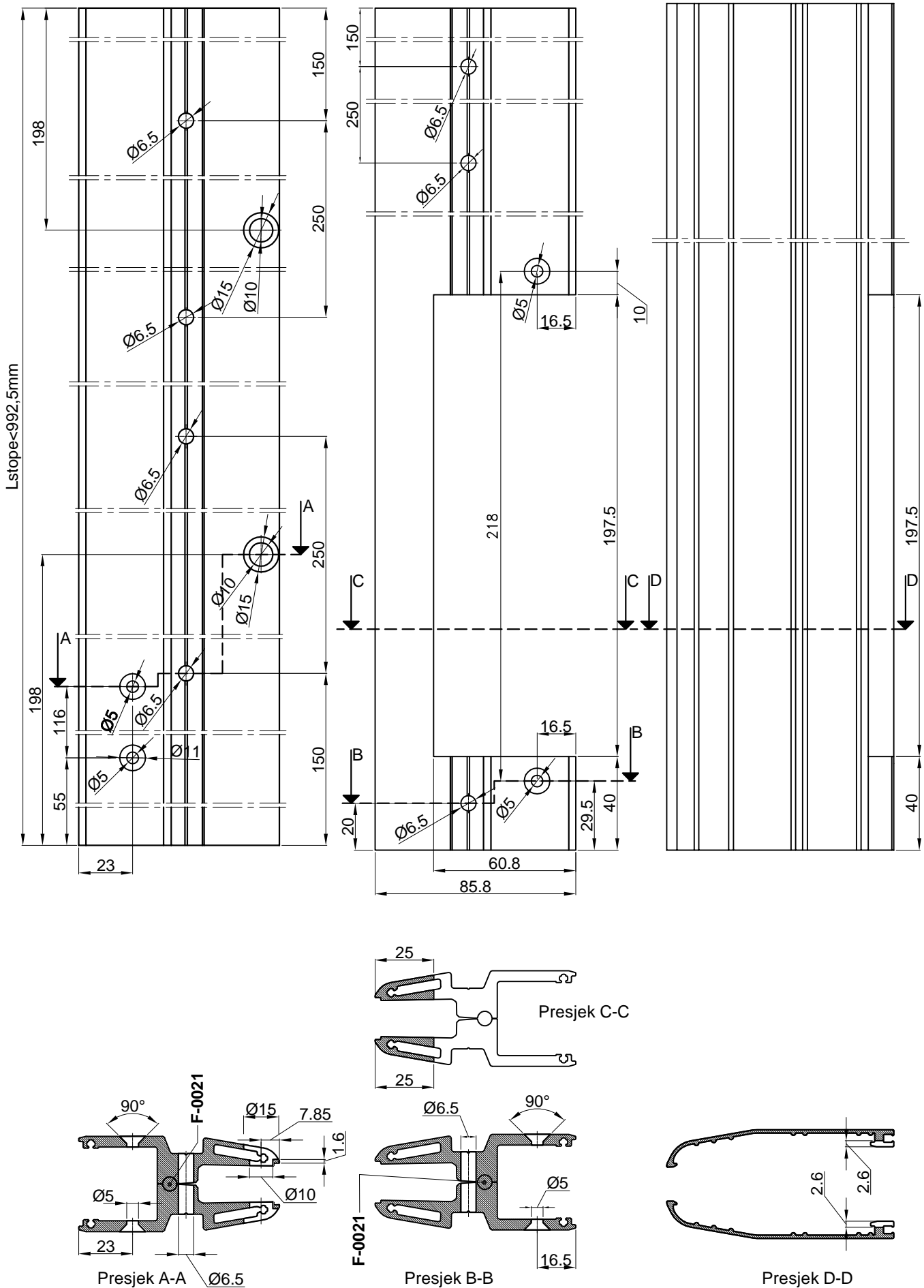

Obrada profila F-1473 za prvo klizno krilo za težinu krila iznad 70 kg

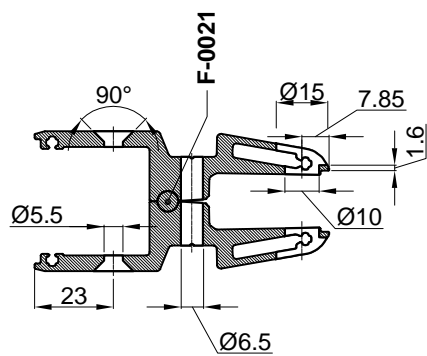
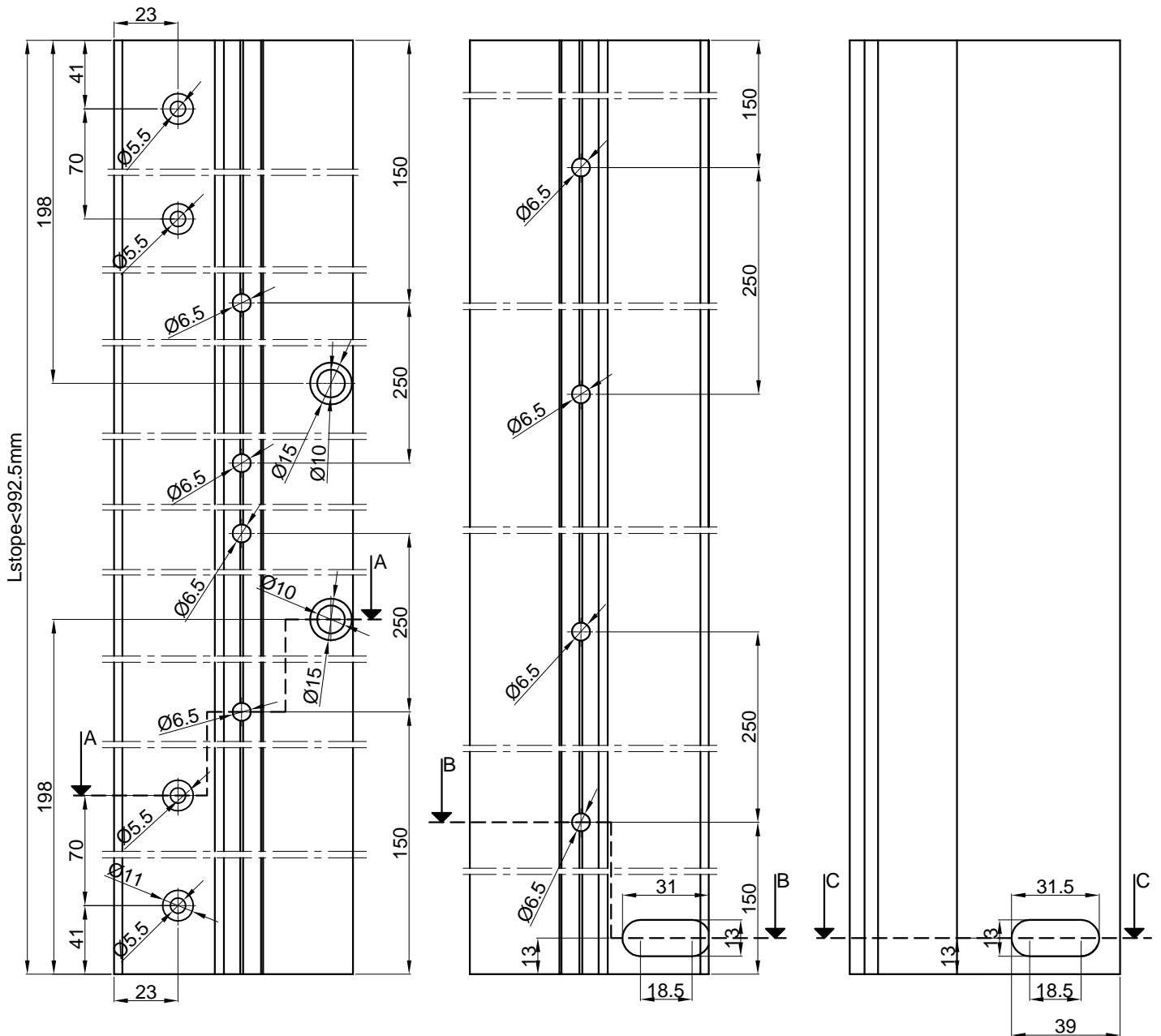

Presjek A-A

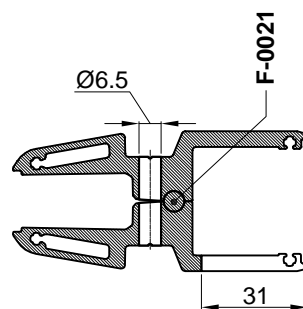

Presjek B-B

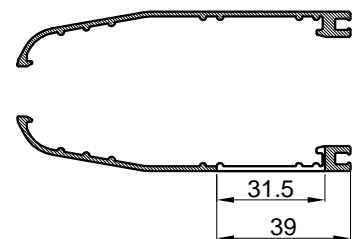

Presjek C-C

Obrada profila F-1473 za srednje klizno krilo za težinu krila iznad 70 kg

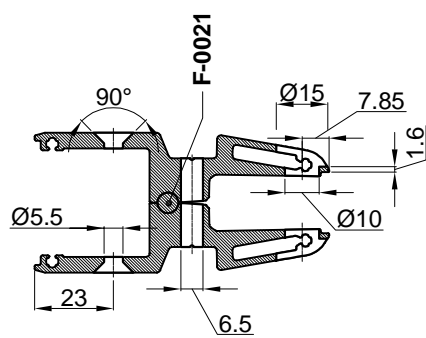
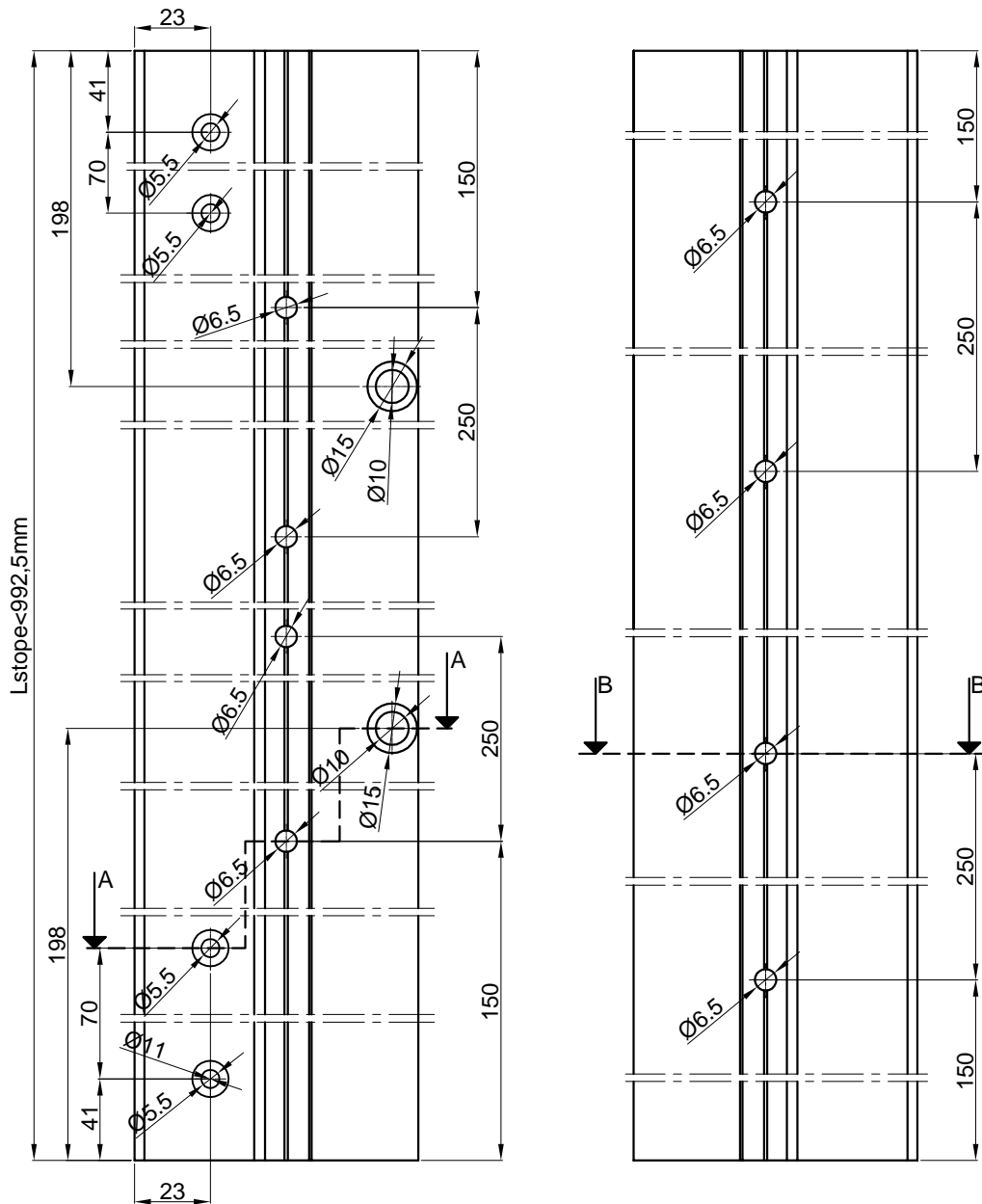

Presjek A-A

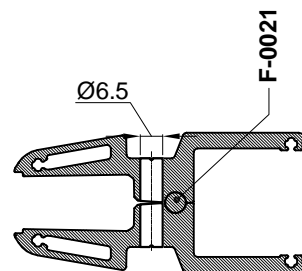

Presjek B-B

Obrada profila F-1473 za zadnje klizno krilo za težinu krila iznad 70 kg

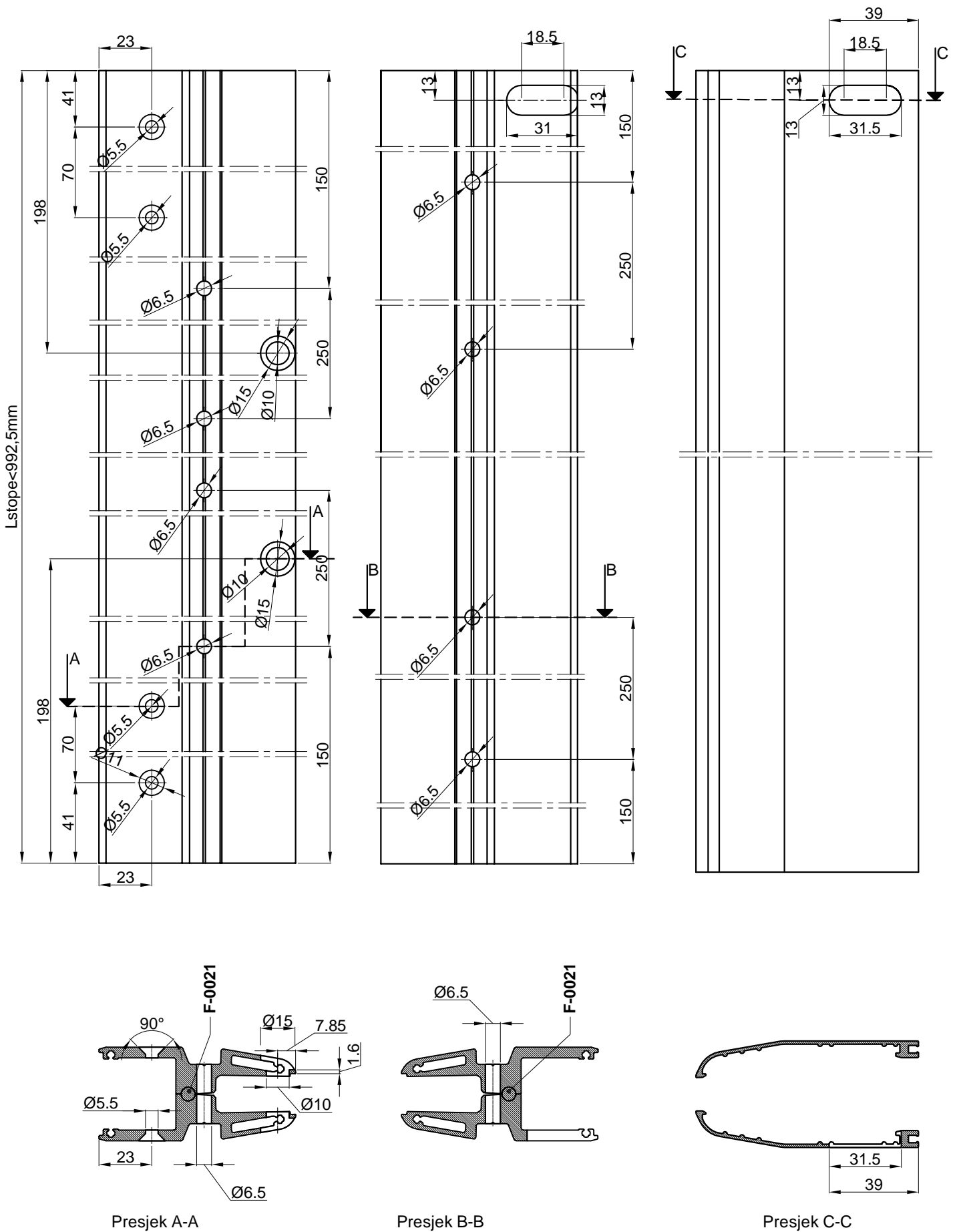

Obrada stope F-1473

! Napomena: Pri bušenju rupe $\varnothing 6.5$ mm potrebno je obratiti pozornost na poziciju bušenja kako bi stezanje vijka M6 dovelo do dovoljno jakog pritiska profila F-1473 na staklo tj do čvršćeg spoja.

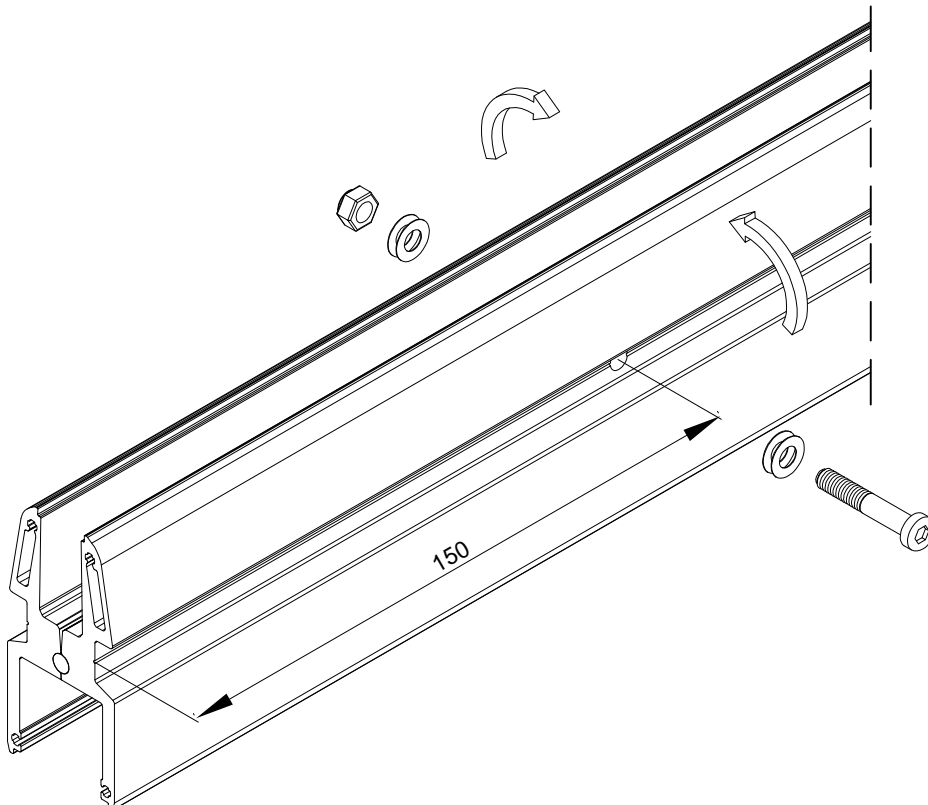
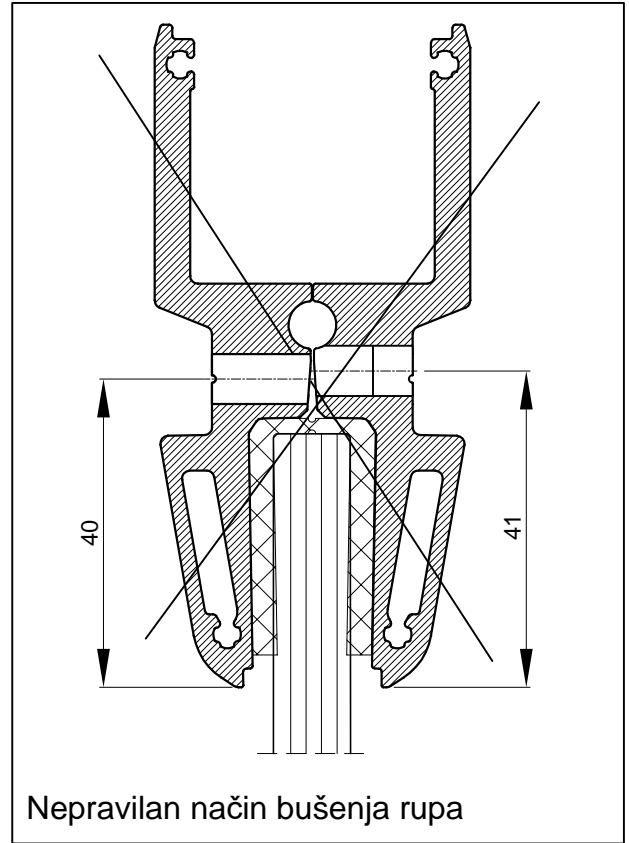
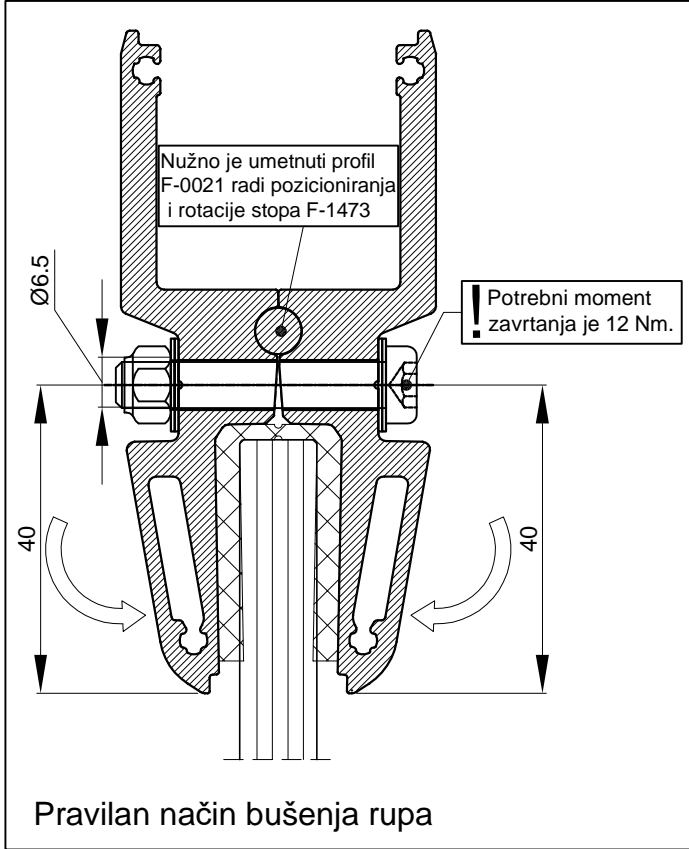

Montaža bočnog podnog zaključanja

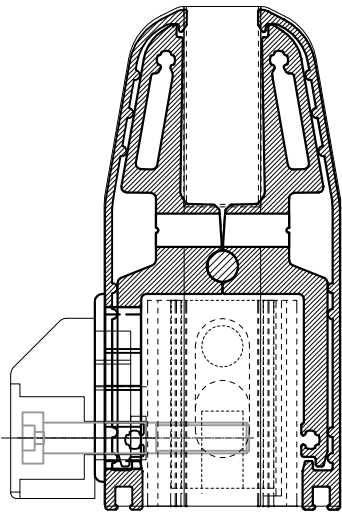
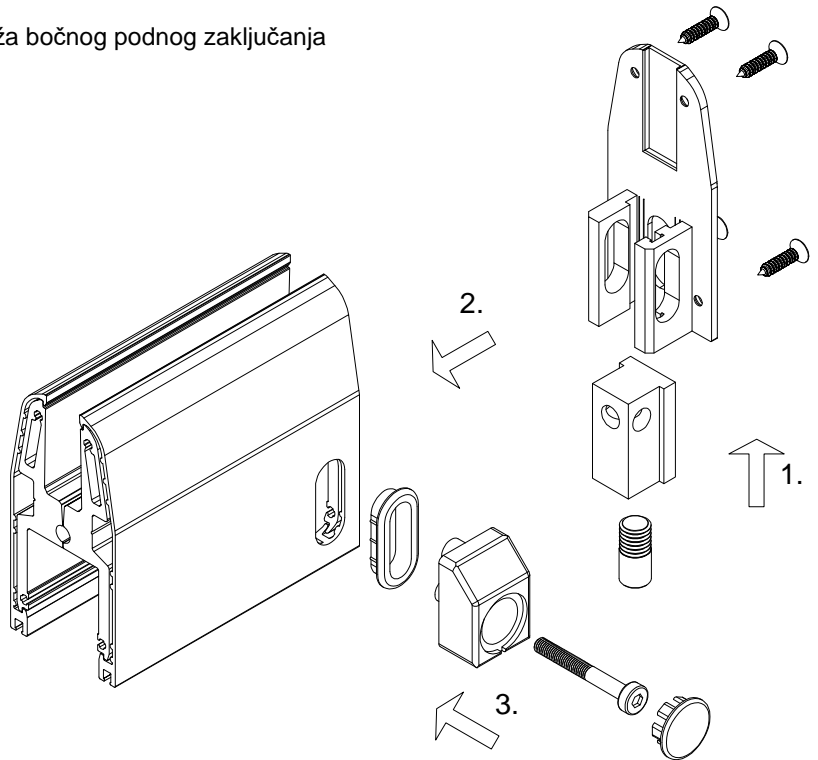
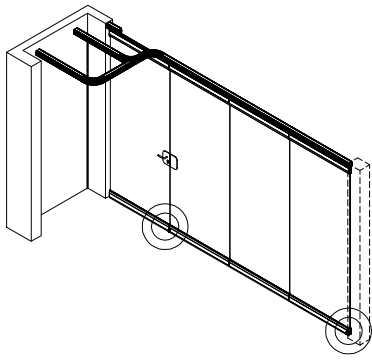

Napomena: Pri zavijanju vijka M6x40 potrebno je ostaviti 1 mm prostora između ručke zaključavanja i PVC umetka na lajсни stope

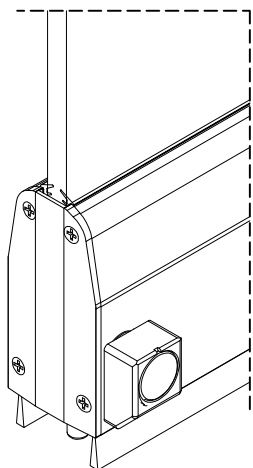
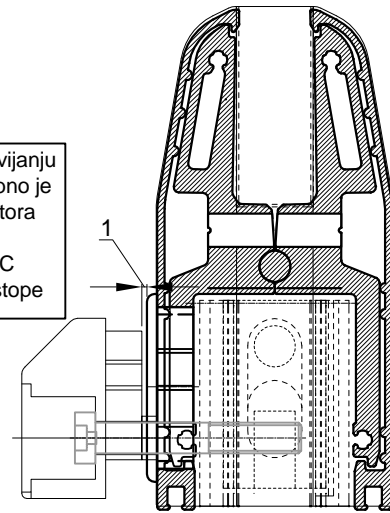

Otvoreni položaj

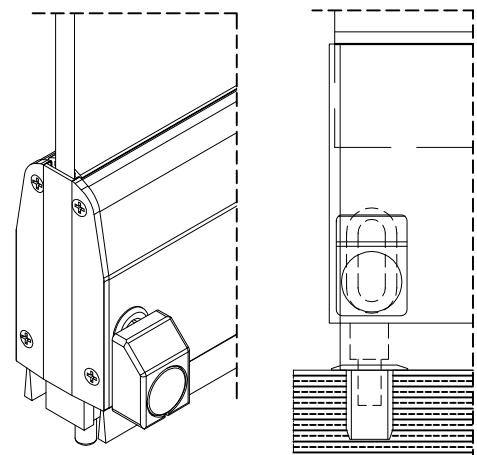
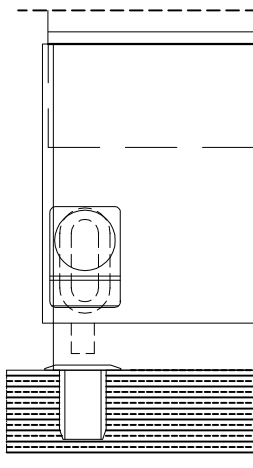

Zatvoreni položaj

Montaža podnog ključanja

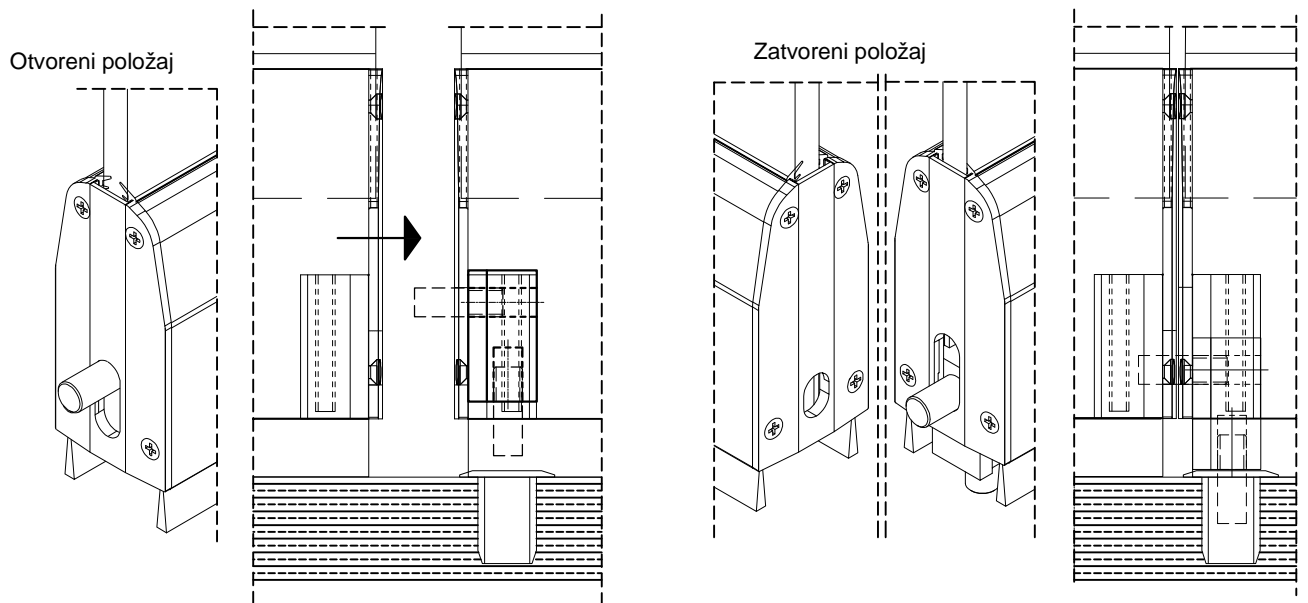
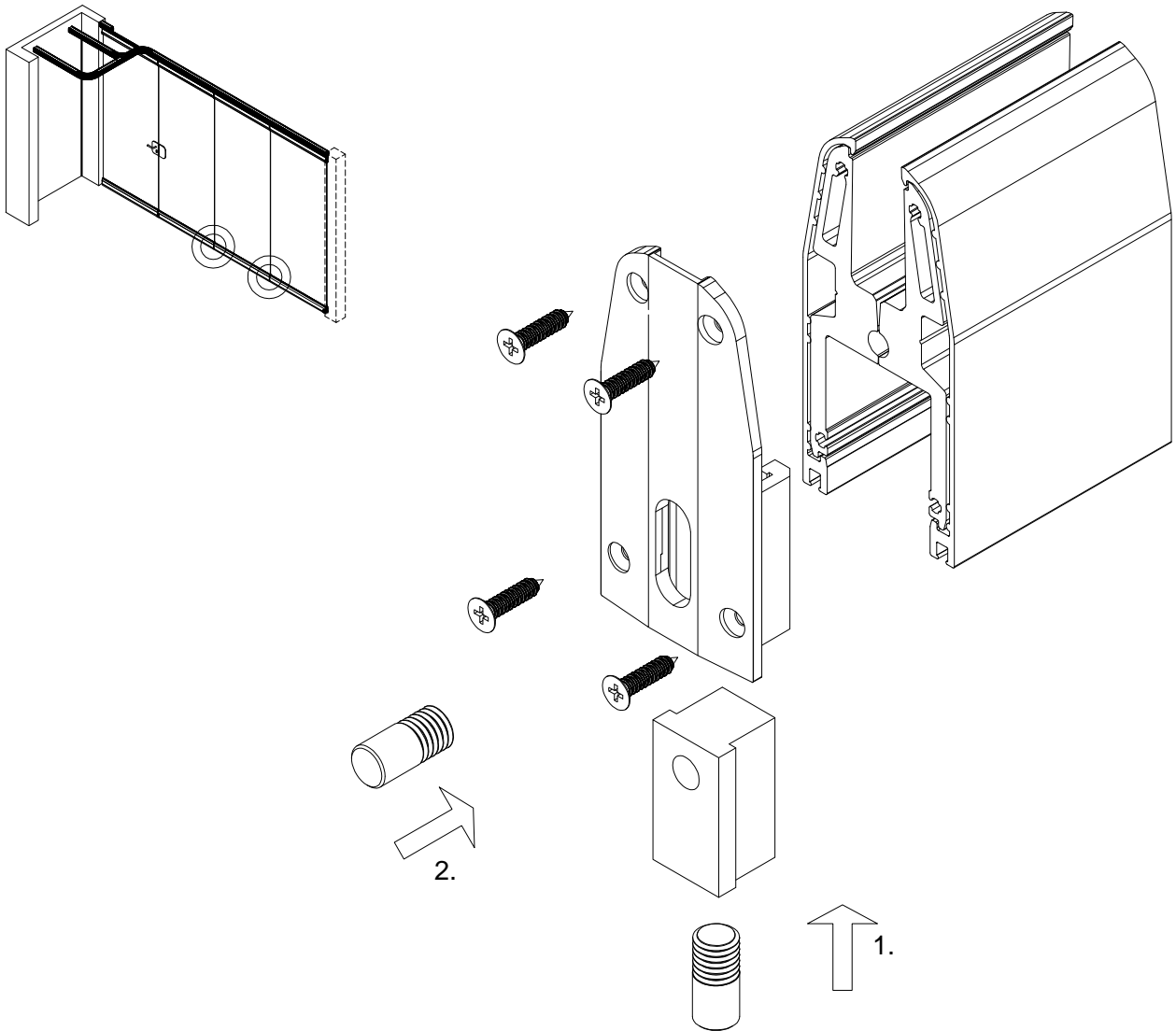

Montaža točkića na kliznim krilima

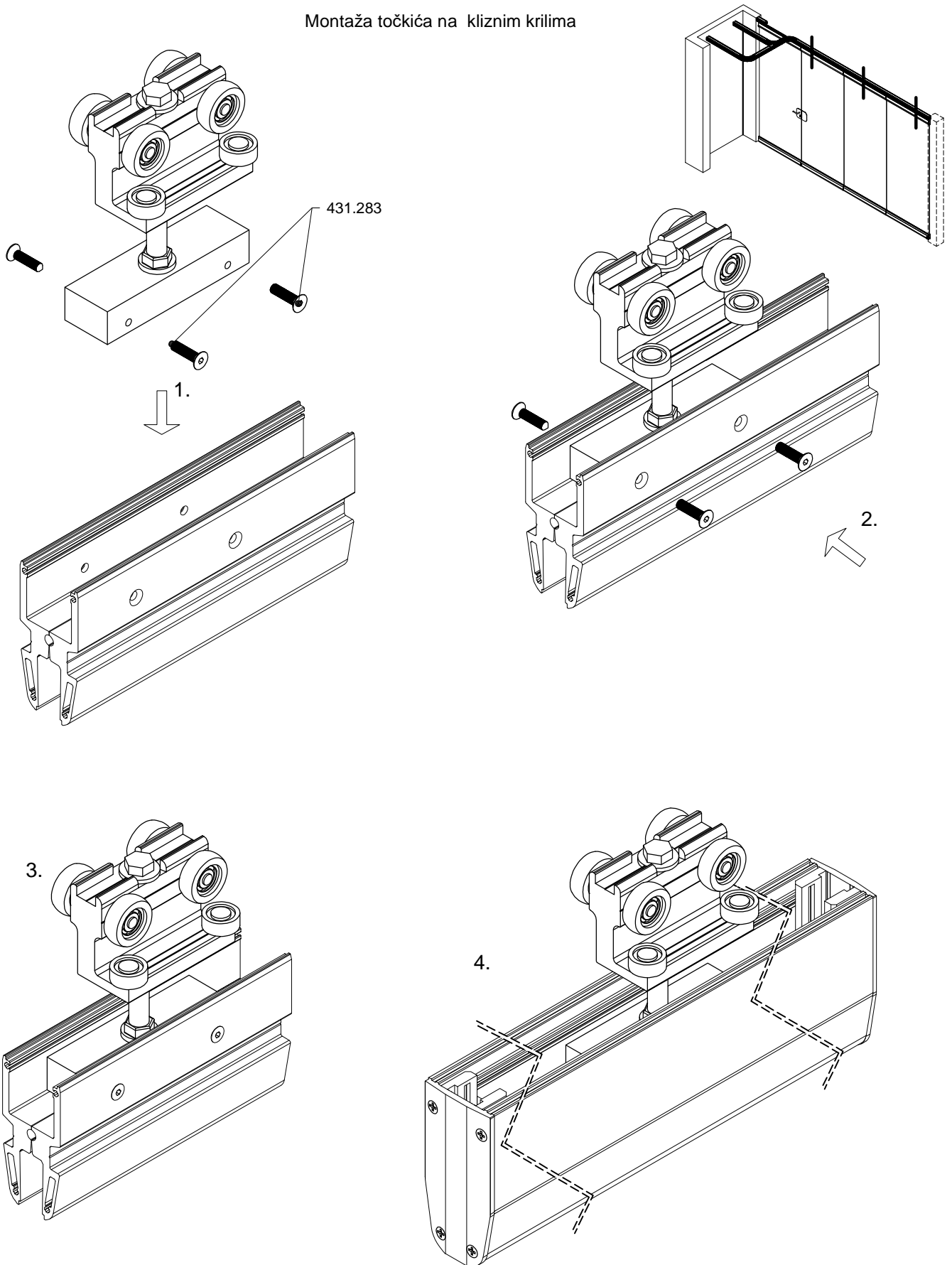

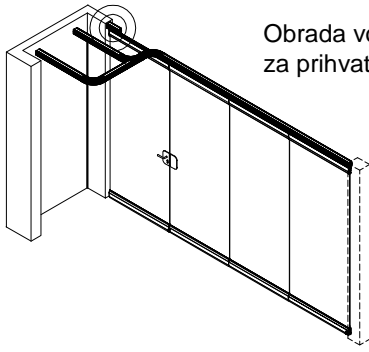

Obrada vodilice i montiranje pločica za prihvat gornjeg okova 146.007

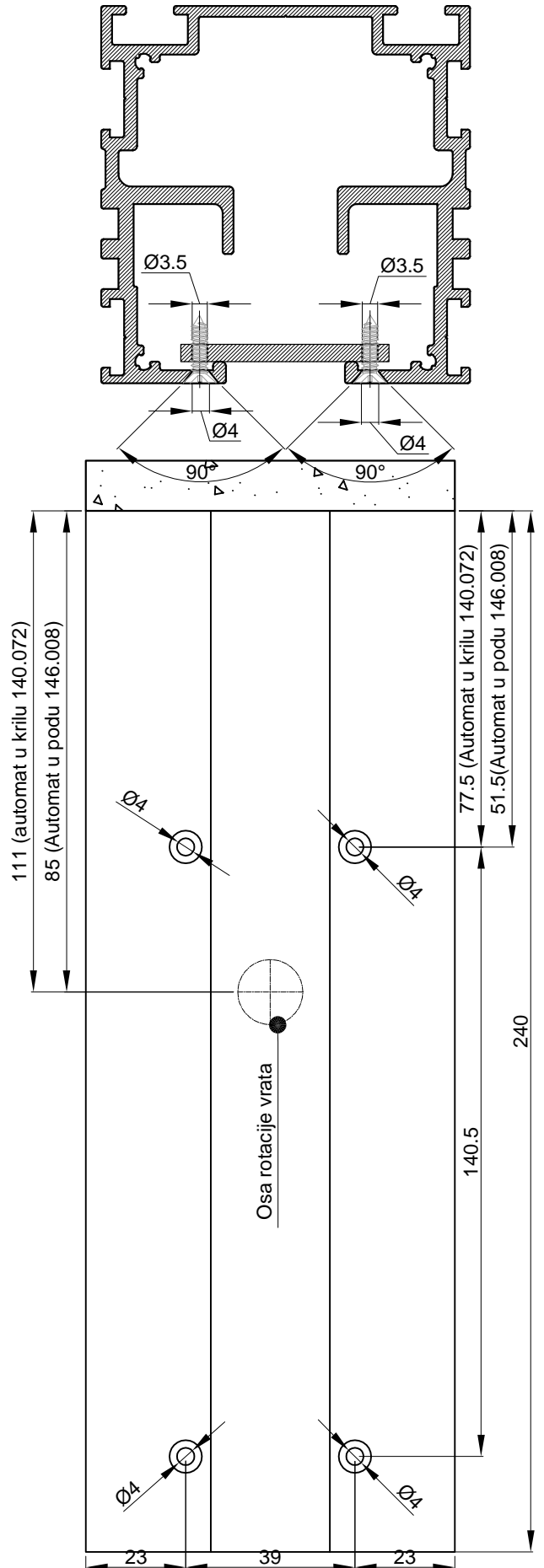
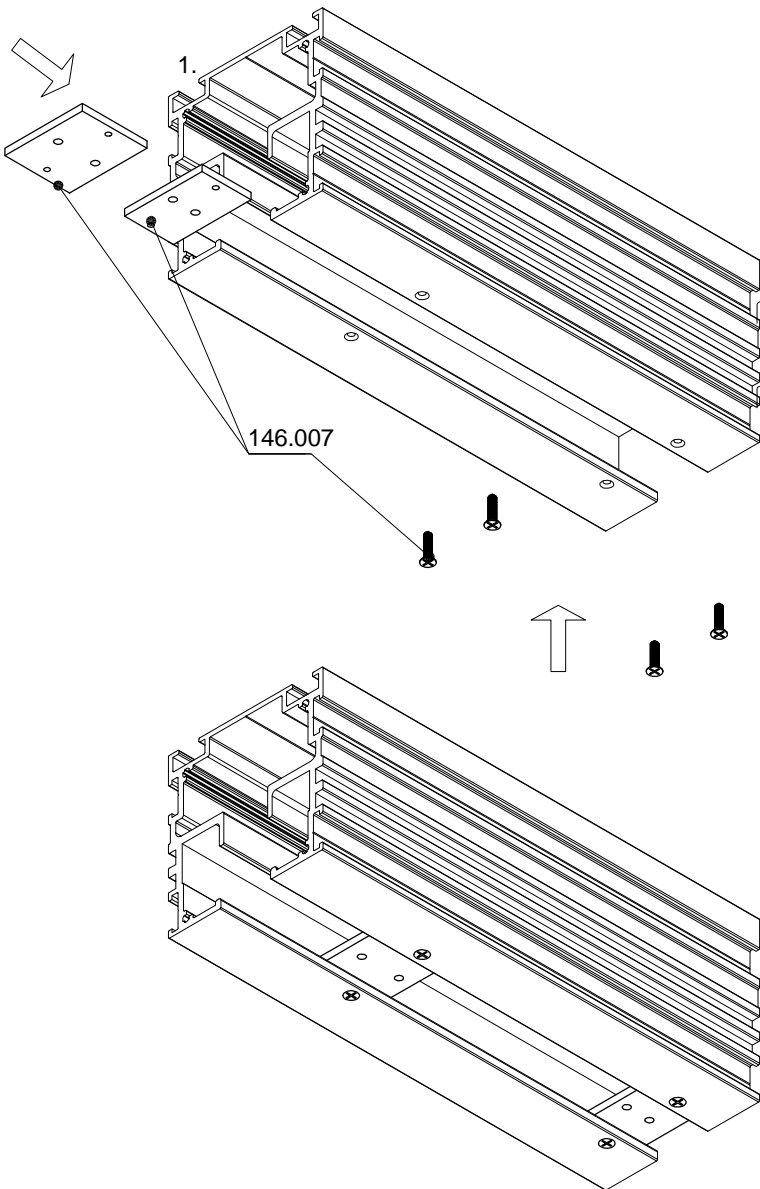

Montiranje gornjeg okova 146.007

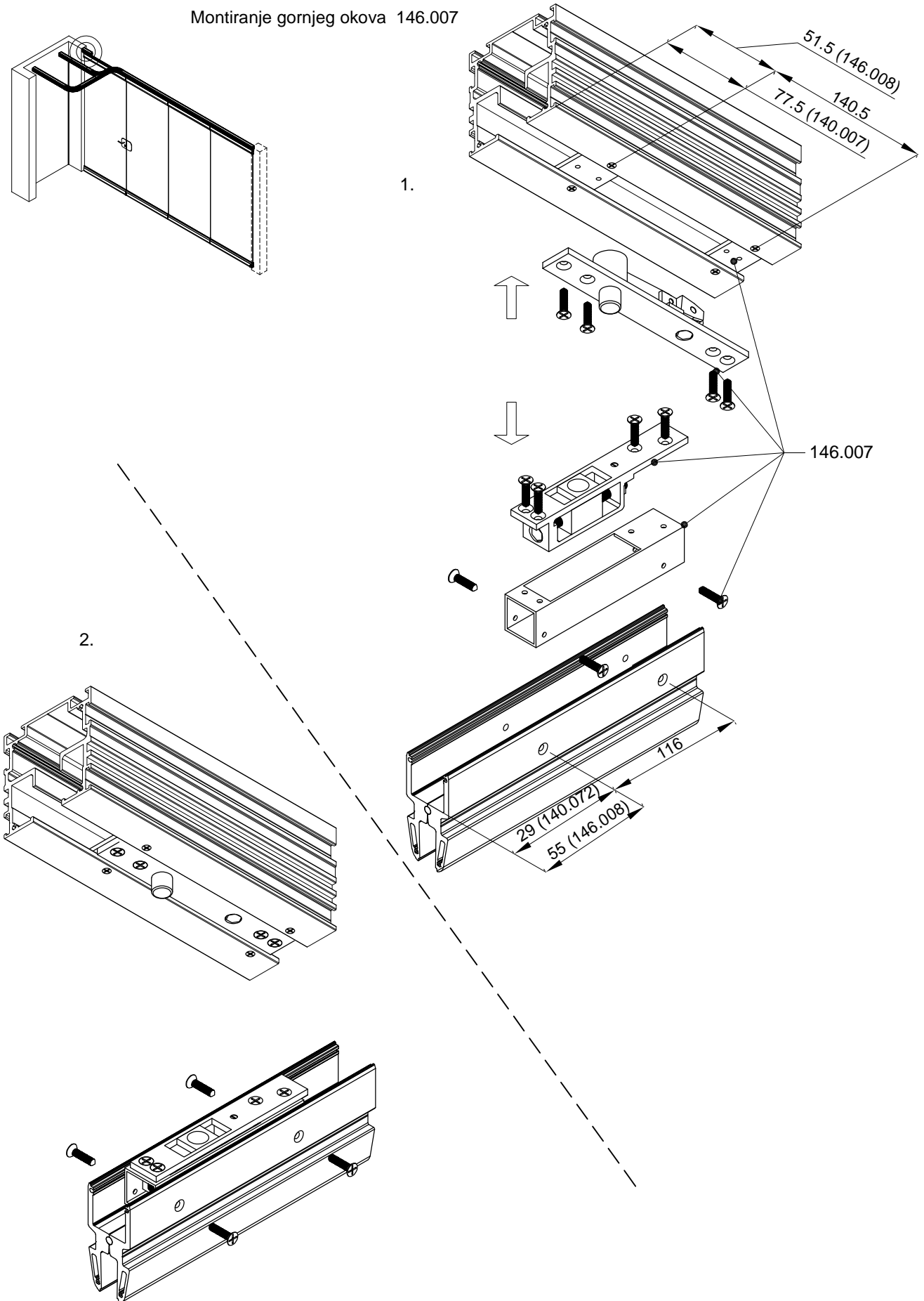

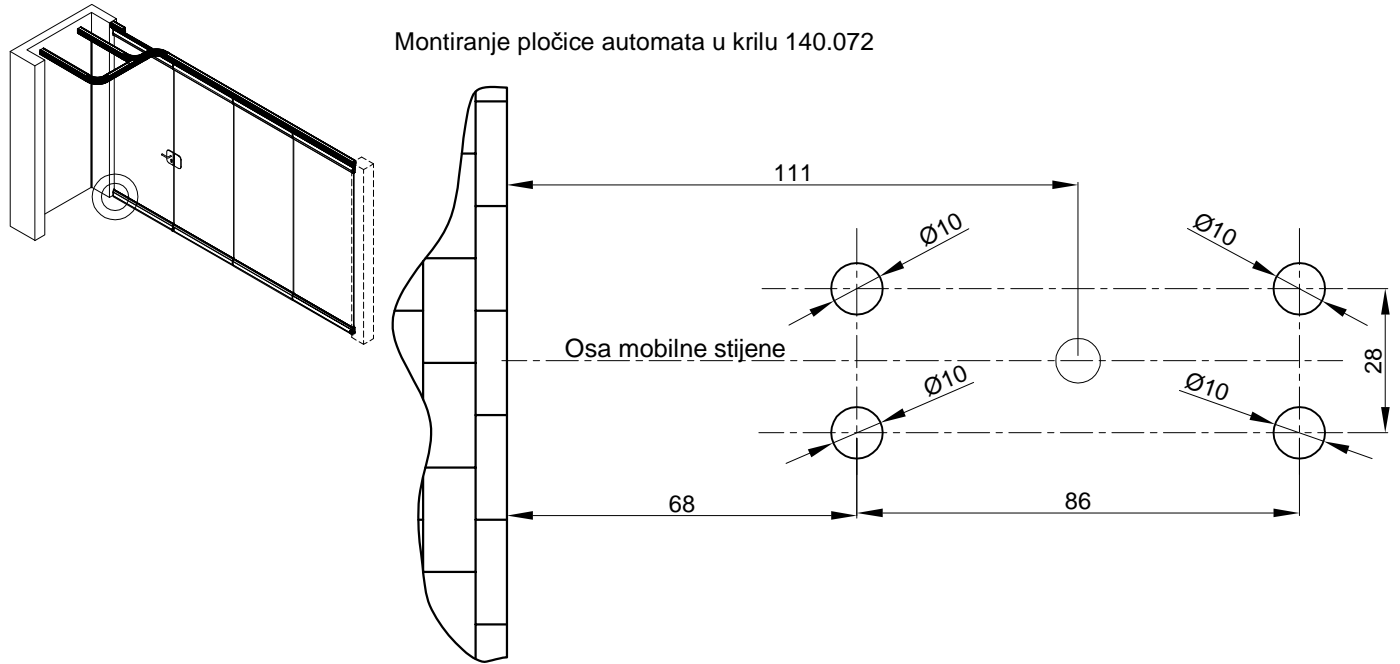

1. Bušenje rupe Ø10

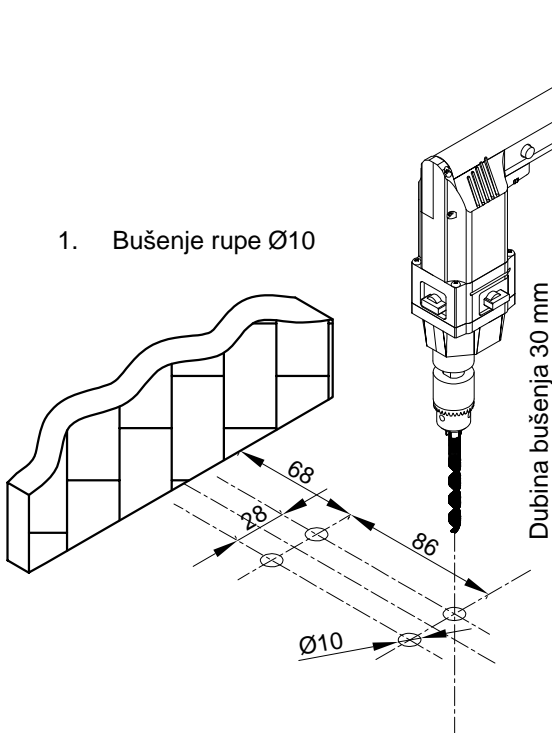

2. Postavljanje čahura za prihvat vijka

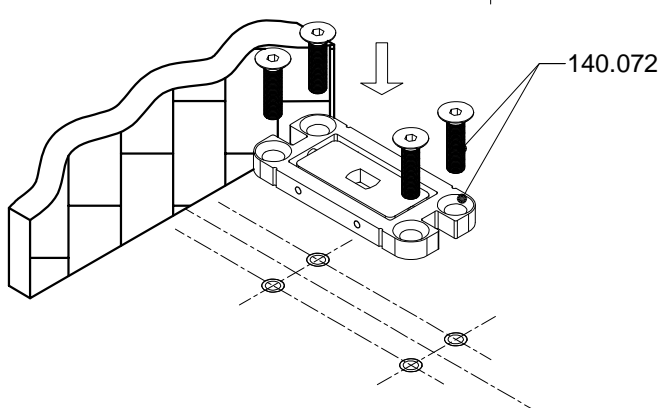
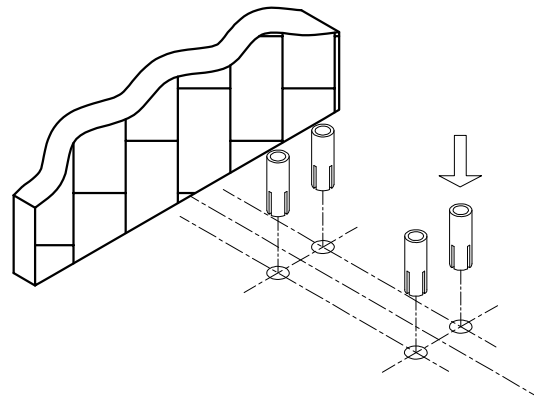

3. Pričvršćivanje pločice vijcima

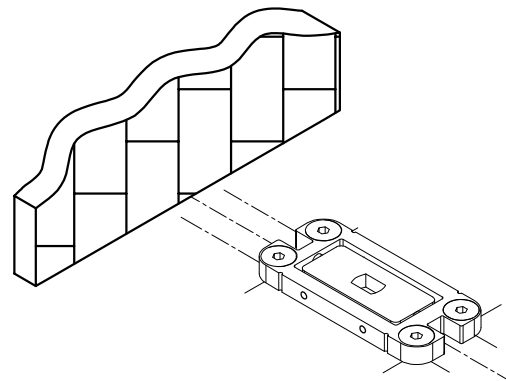

4. Montirana pločica

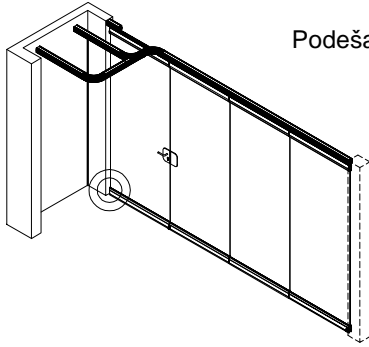

Podešavanje pločice automata u krilu 140.072

1. Podešavanje pločice po osi mobilne stijene

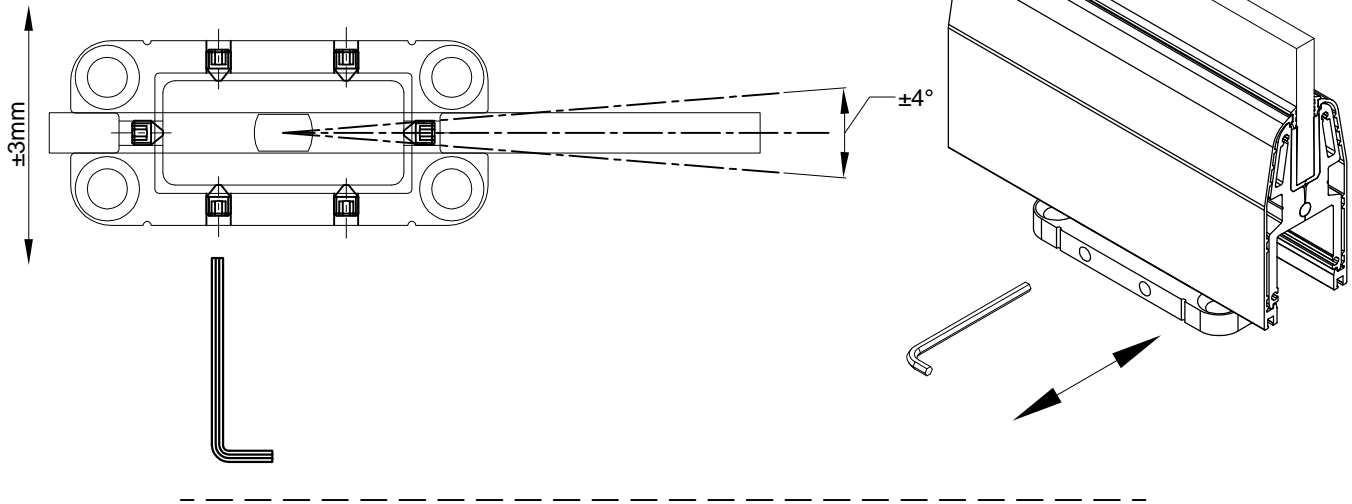

2. Podešavanje pozicije pločice okomito na osu mobilne stijene

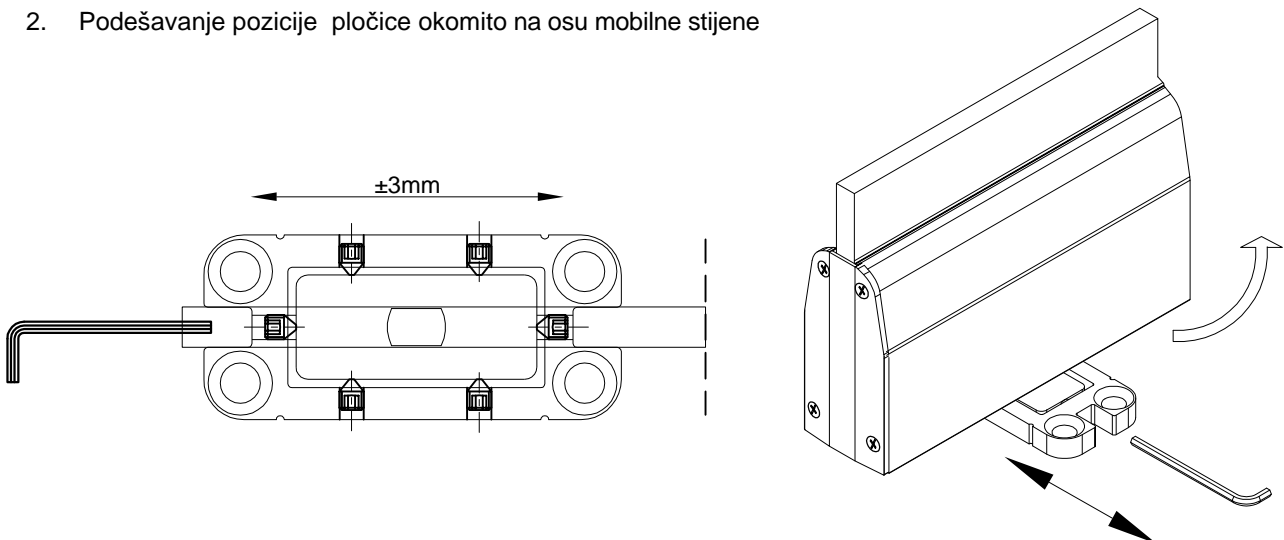

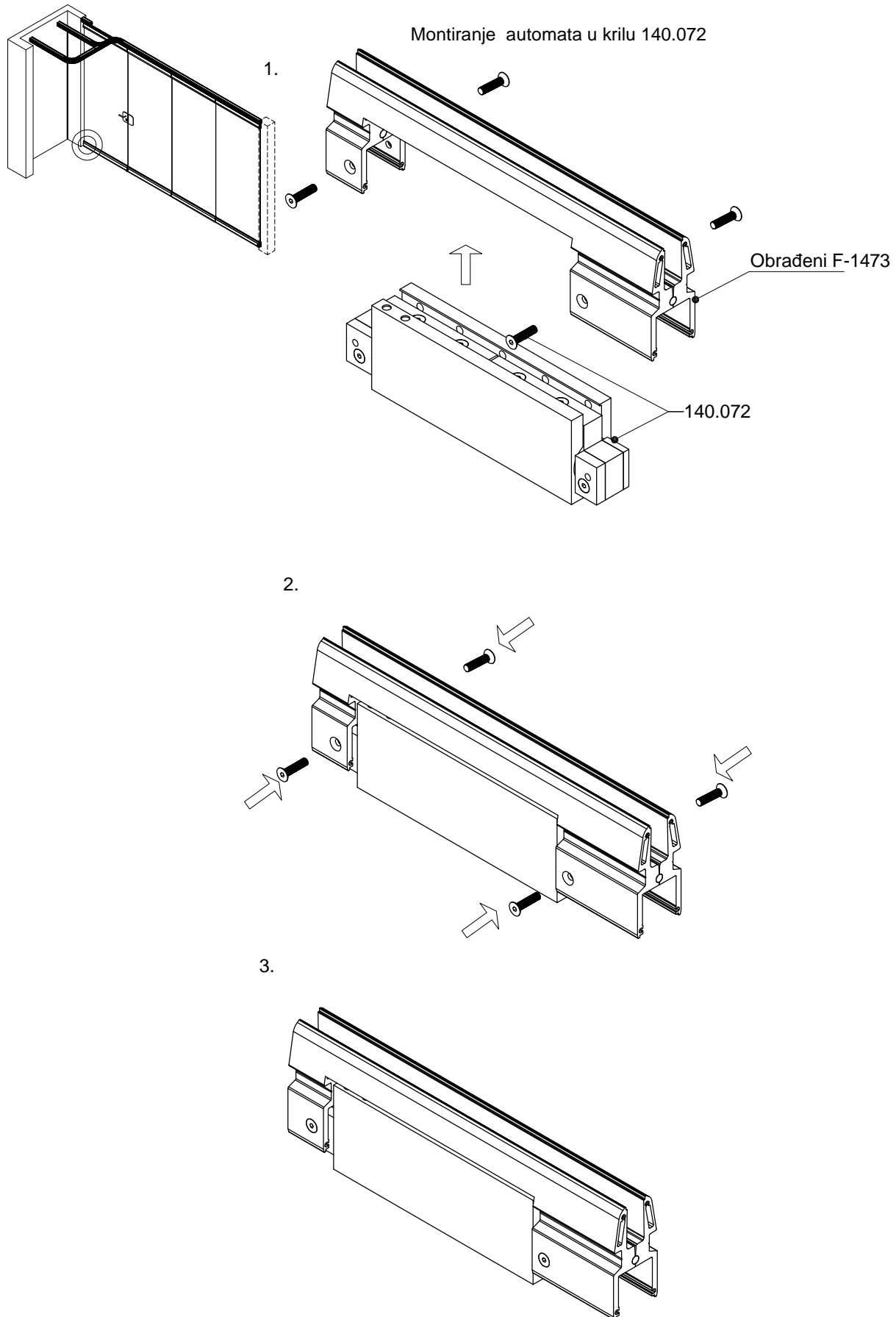

Montiranje donjeg automata u podu 146.008

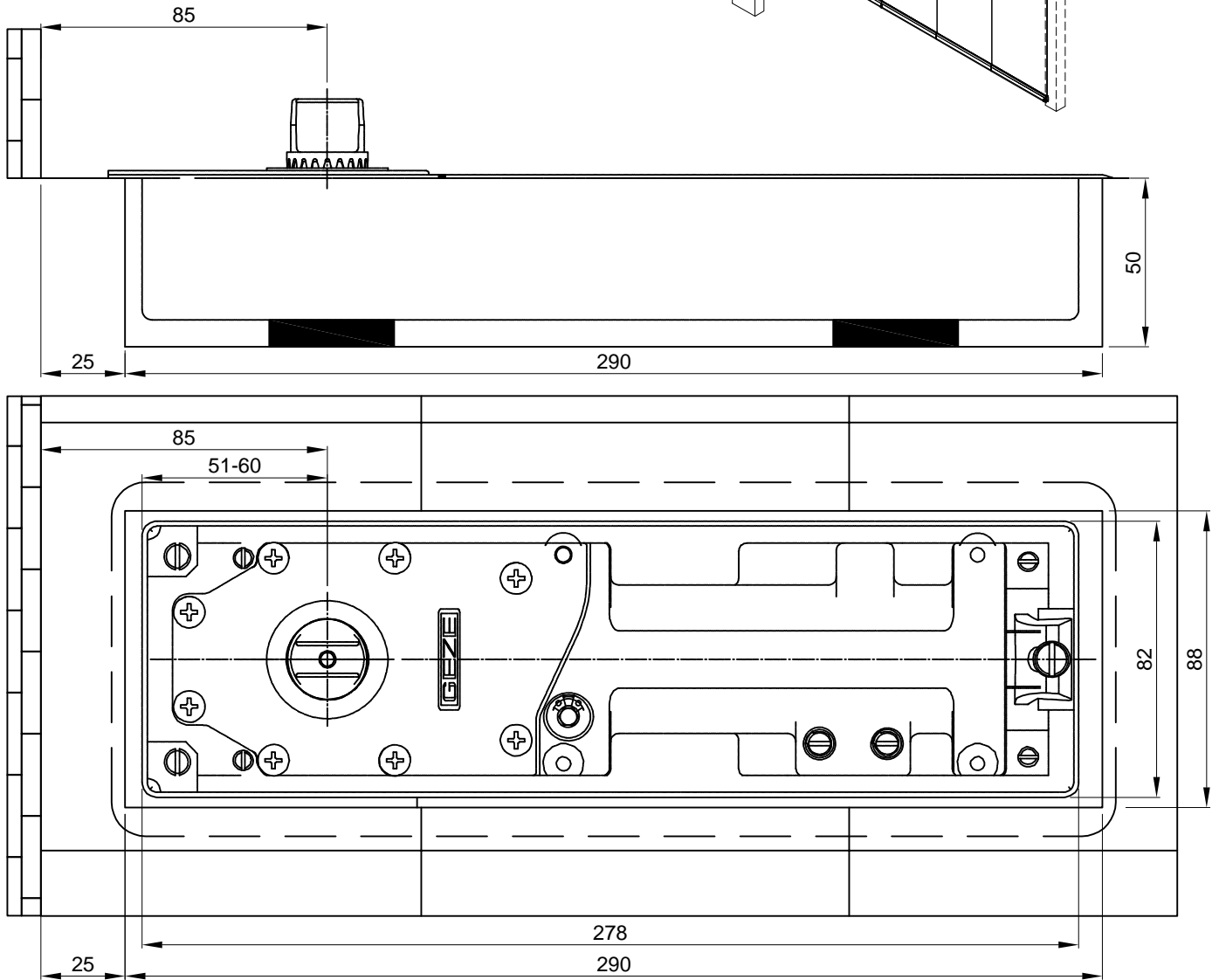
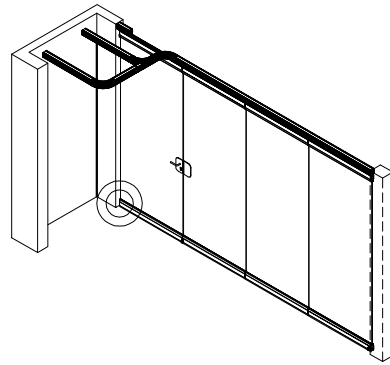

1. Dimenzije rupe za automat u podu

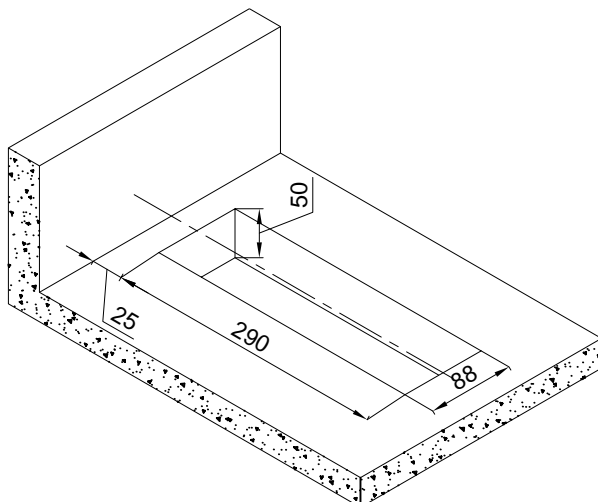

2. Pozicioniranje automata

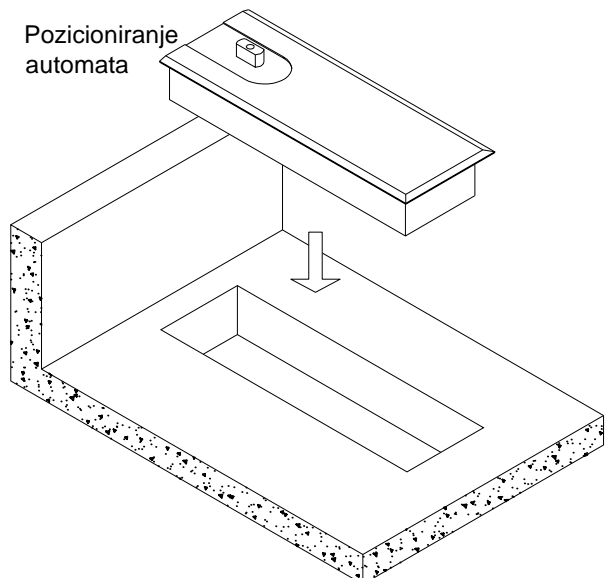

Montiranje poluge u donju stopu

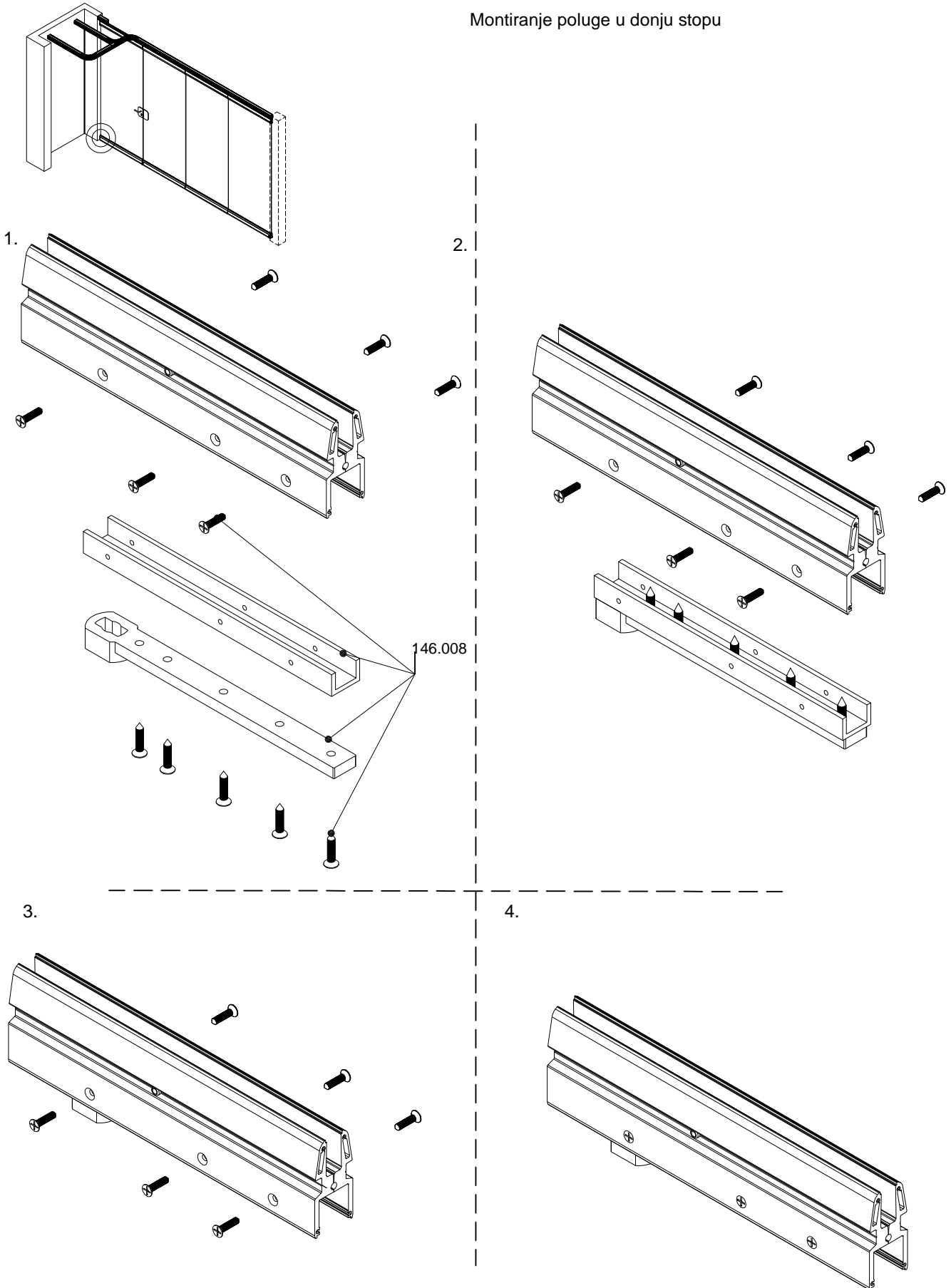

Montiranje mimokretnih vrata

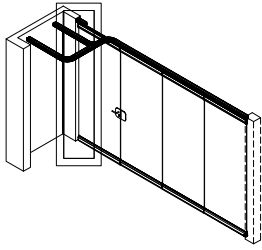

1. Podizanje trna zbog nanošenja vrata

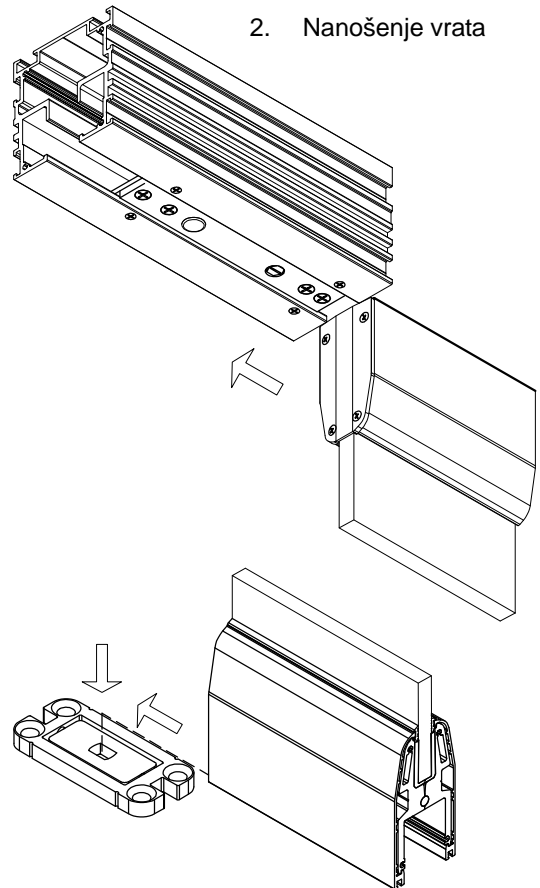
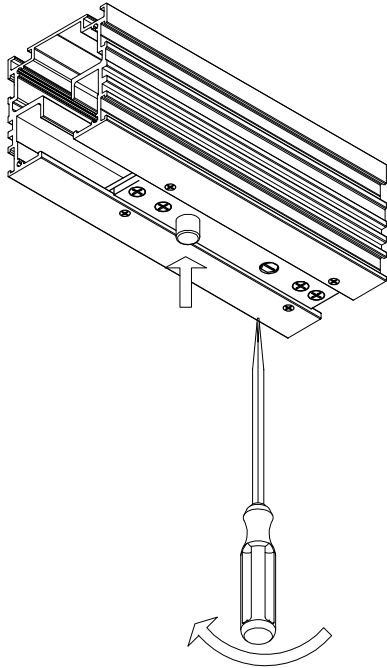

2. Nanošenje vrata

3. Spuštanje trna

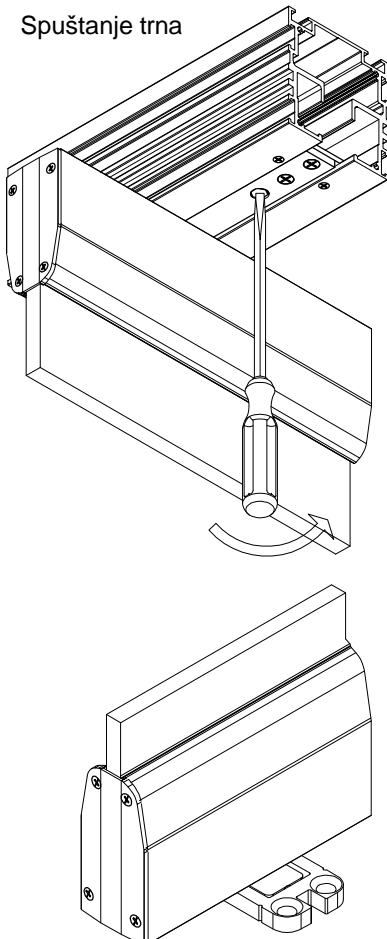

4. Montirana vrata

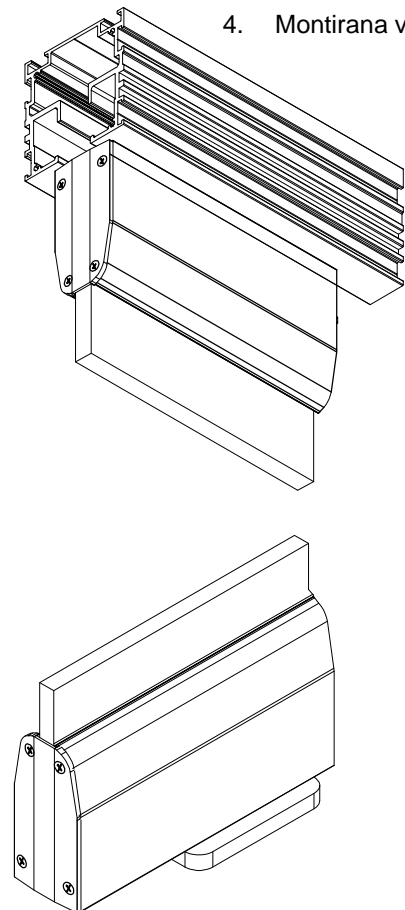

Montiranje sigurnosnog držača stakla za težine krila iznad 70 kg

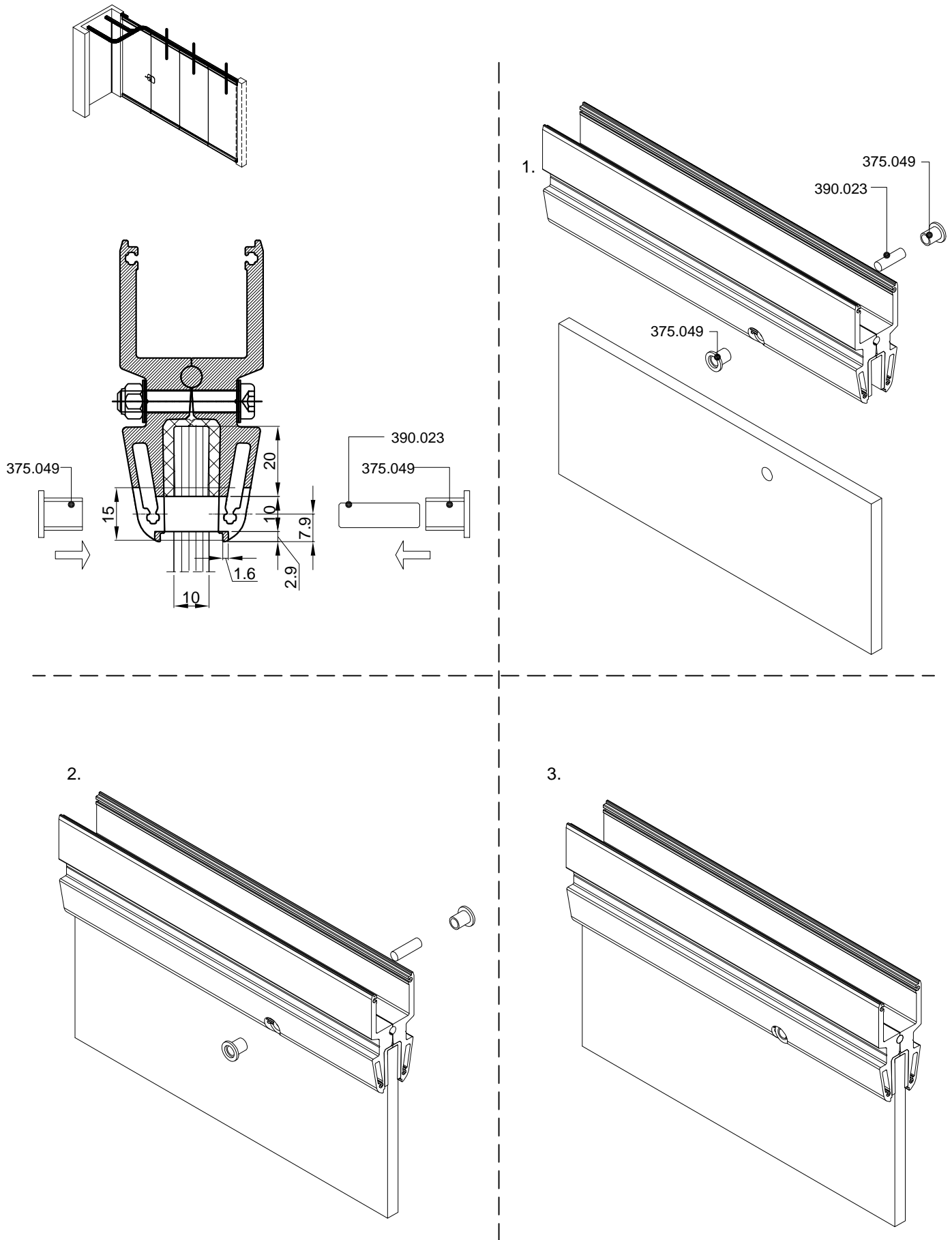

Montiranje stopera na kraju parking prostora

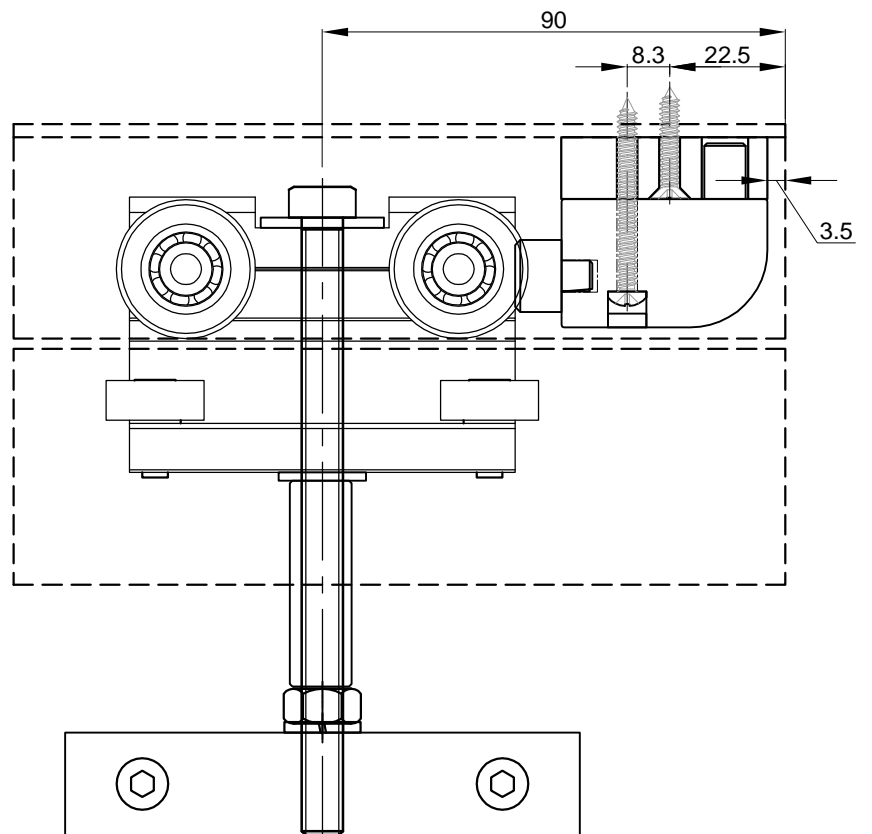
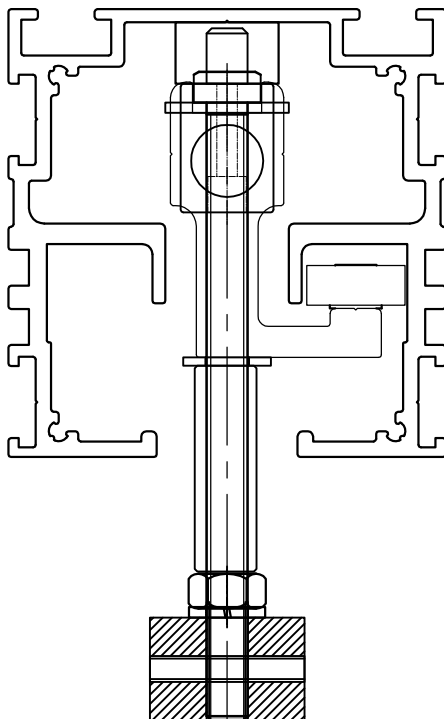
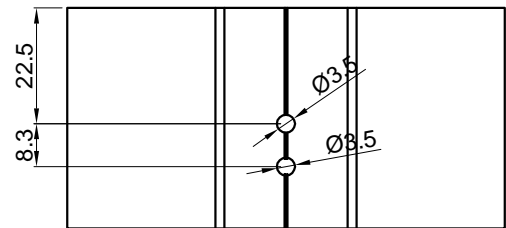
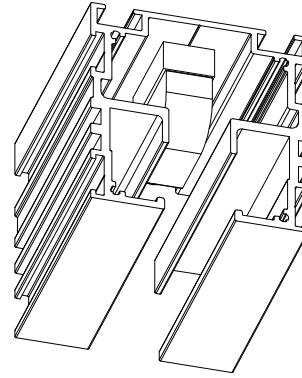
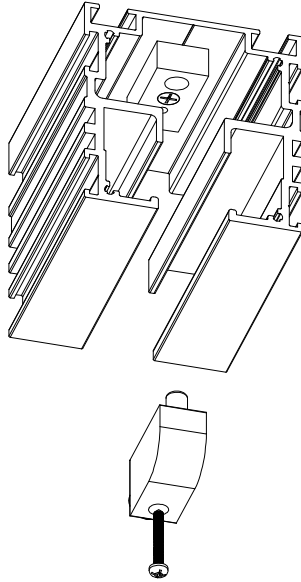
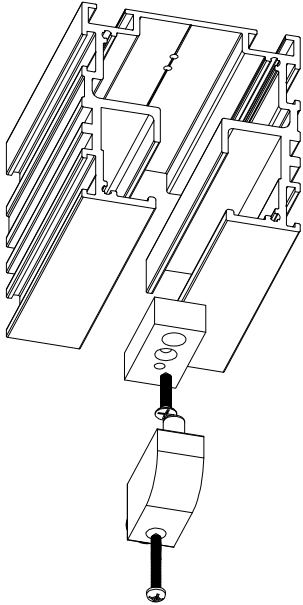
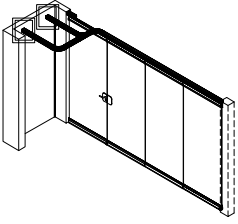

Spajanje vodilice F-1504 sa elementima skretanja

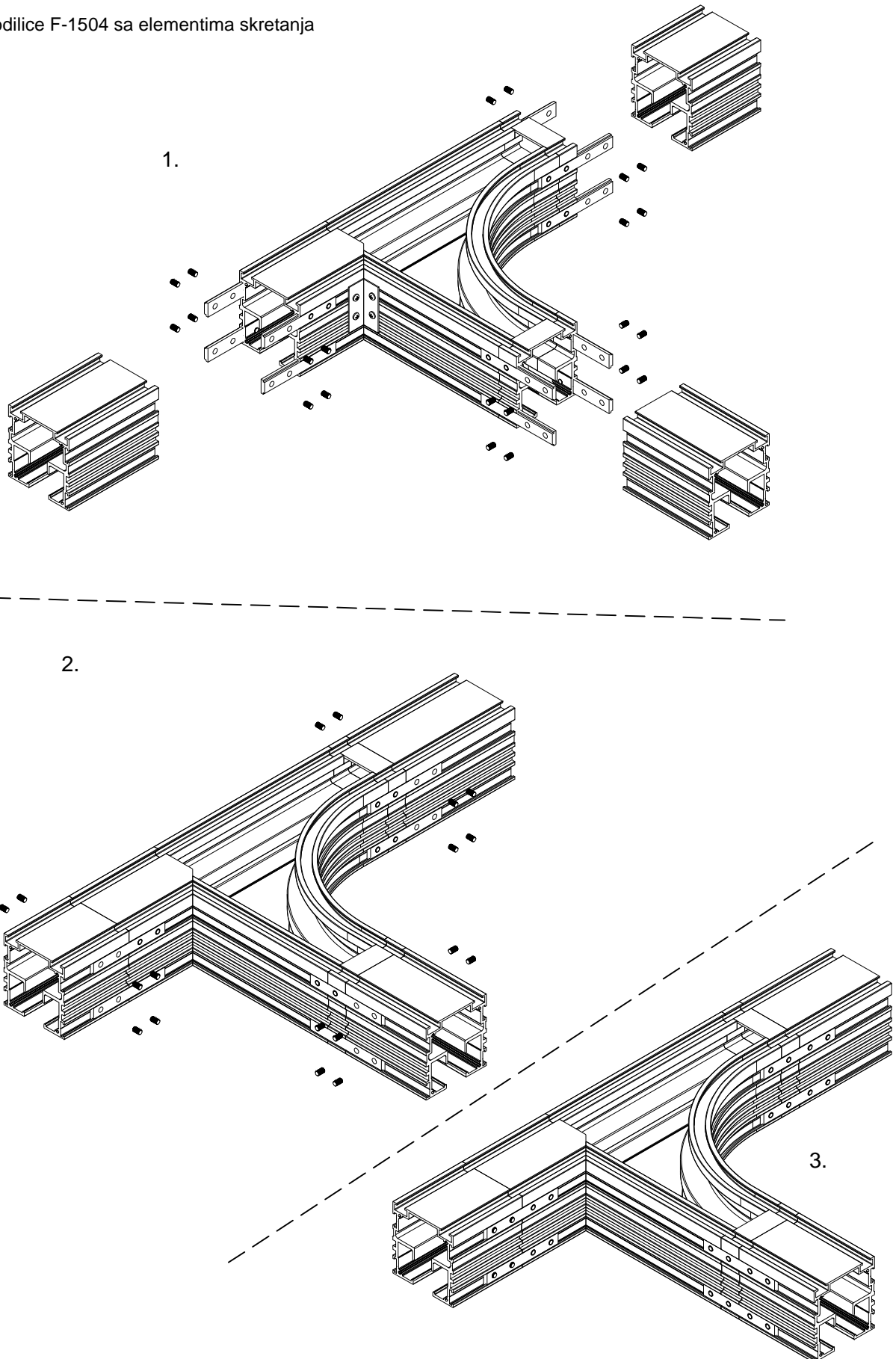

Zaokretno krilo harmonika otvaranje

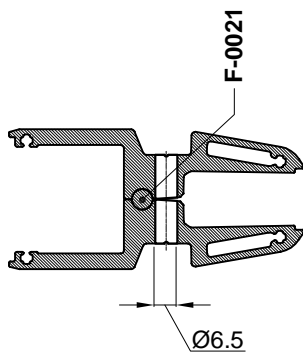
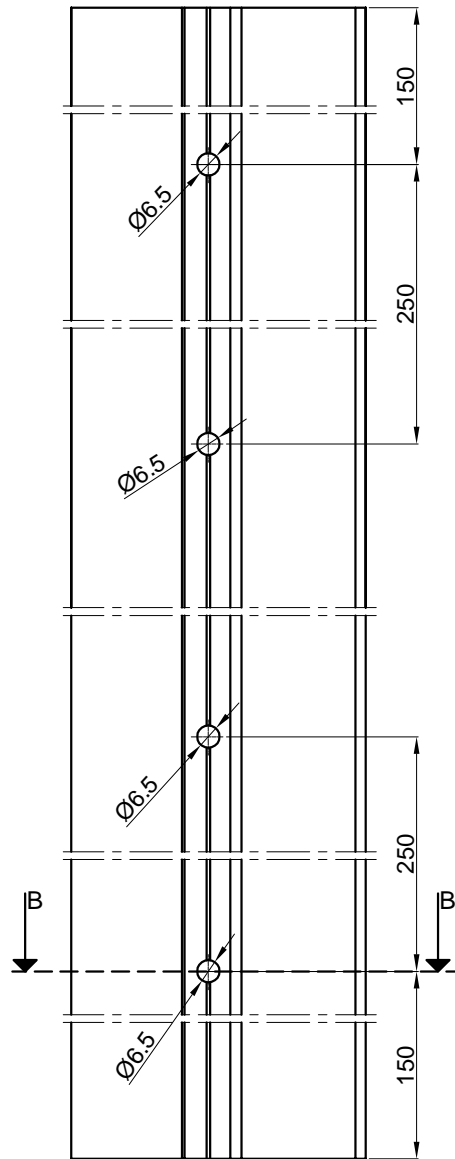
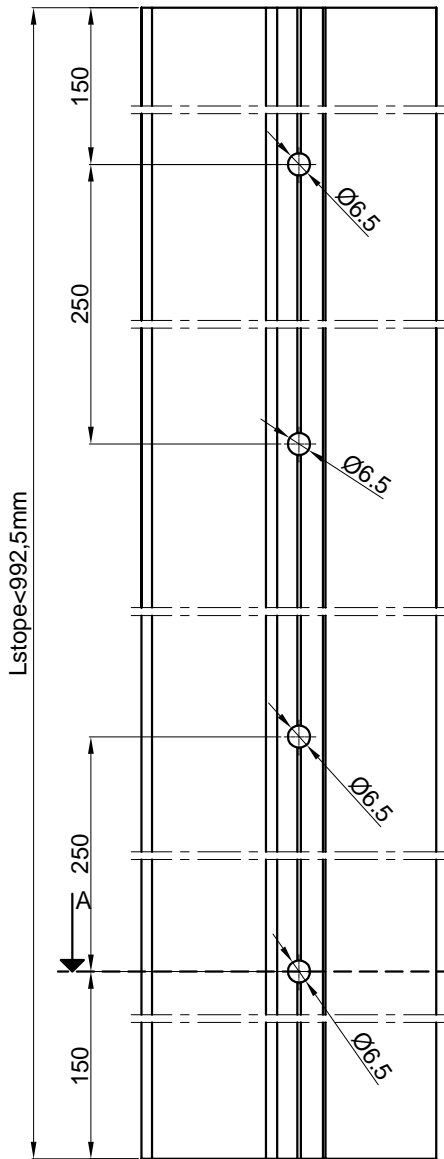

Presjek A-A

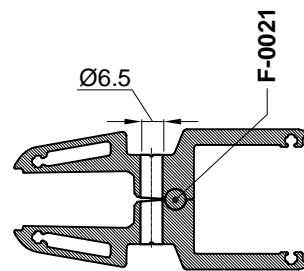

Presjek B-B

Obrada profila F-1473 za srednja krila

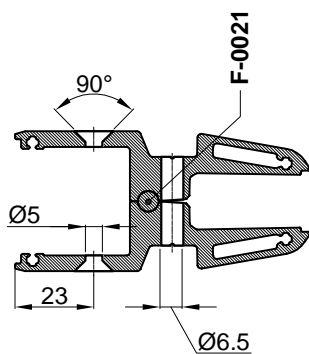
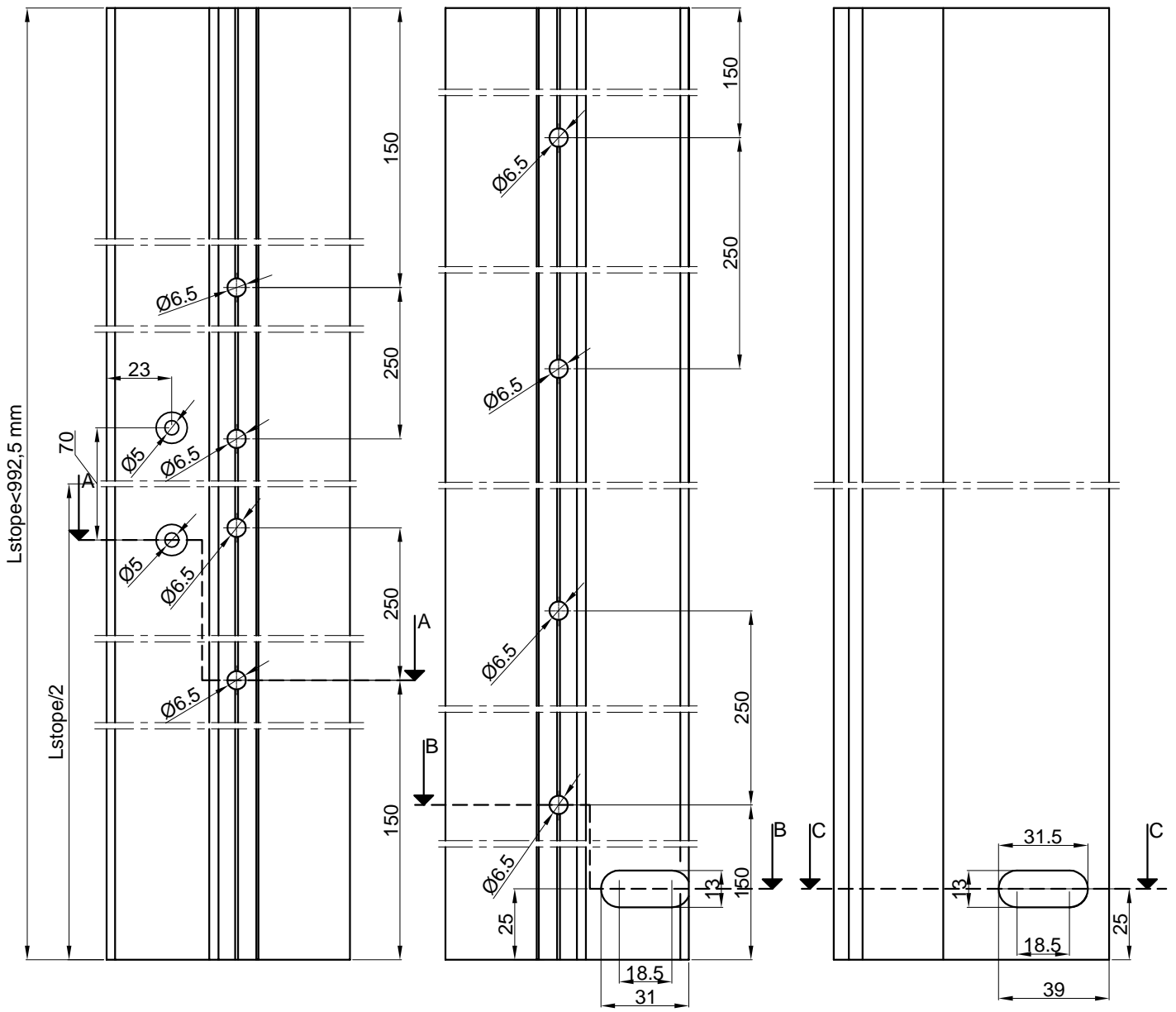

Presjek A-A

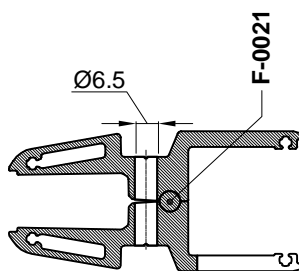

Presjek B-B

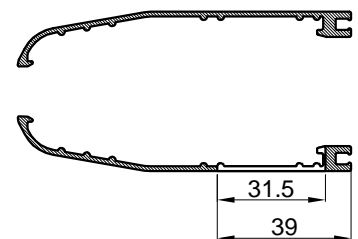

Presjek C-C

Malo (prvo) krilo harmonika otvaranje

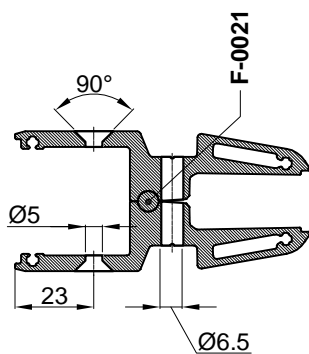
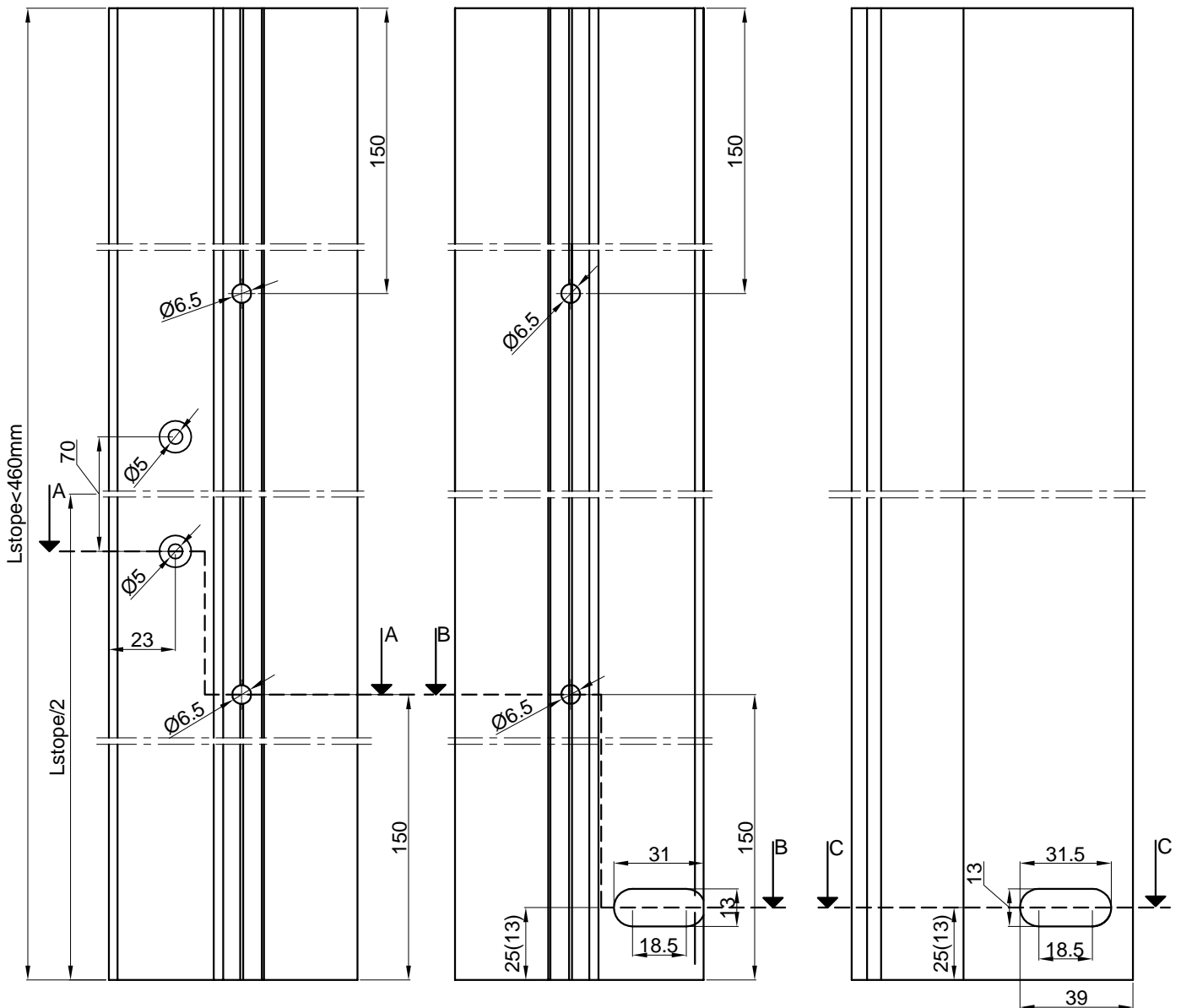

Presjek A-A

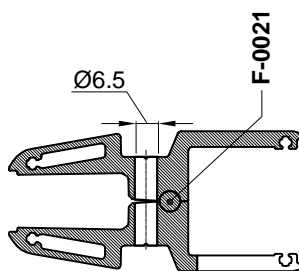

Presjek B-B

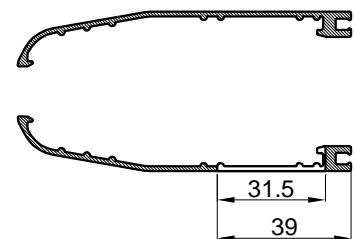

Presjek C-C

Montaža točkića na harmonika krilima

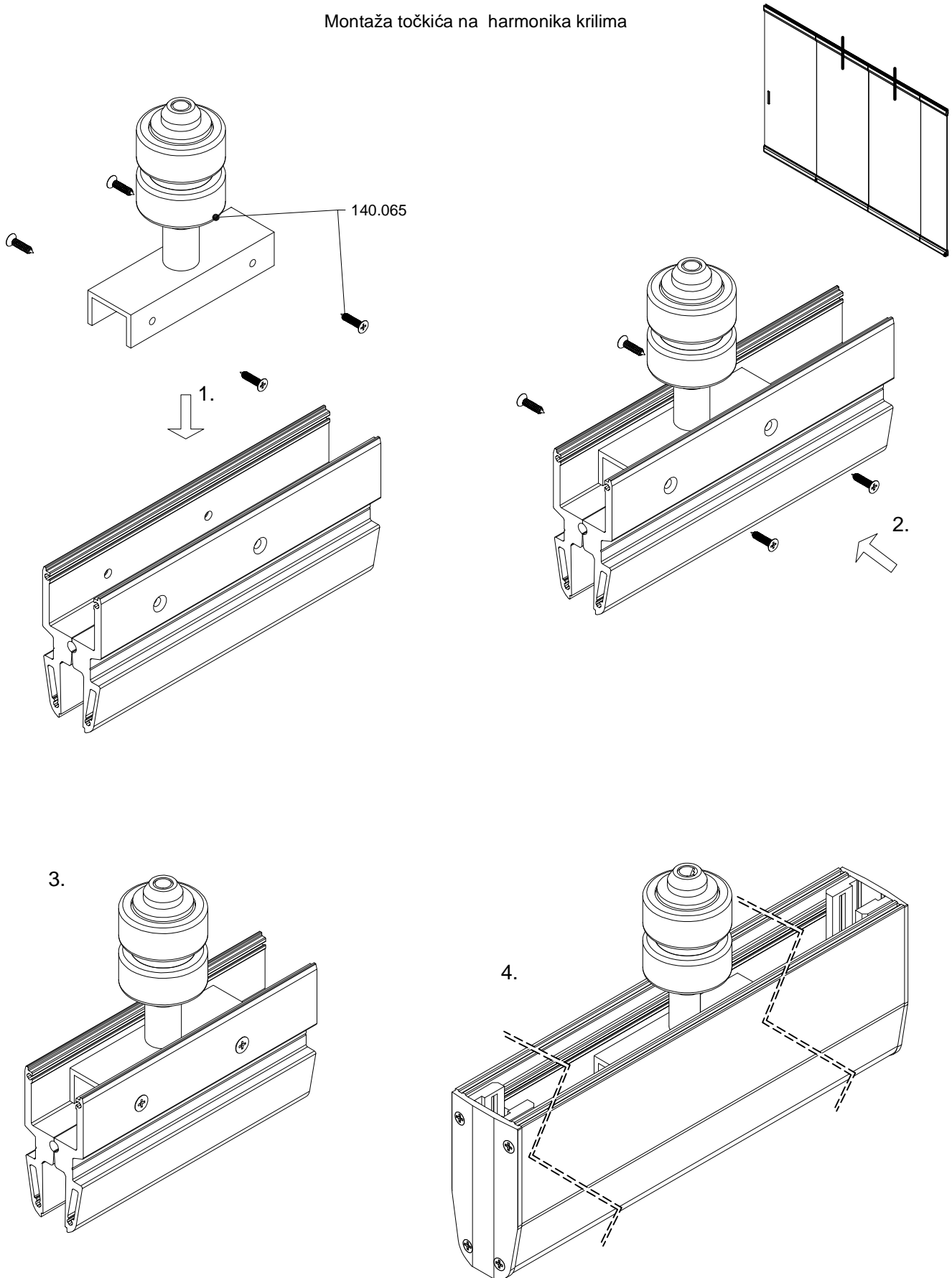

Montaža točkića na harmonika krilima

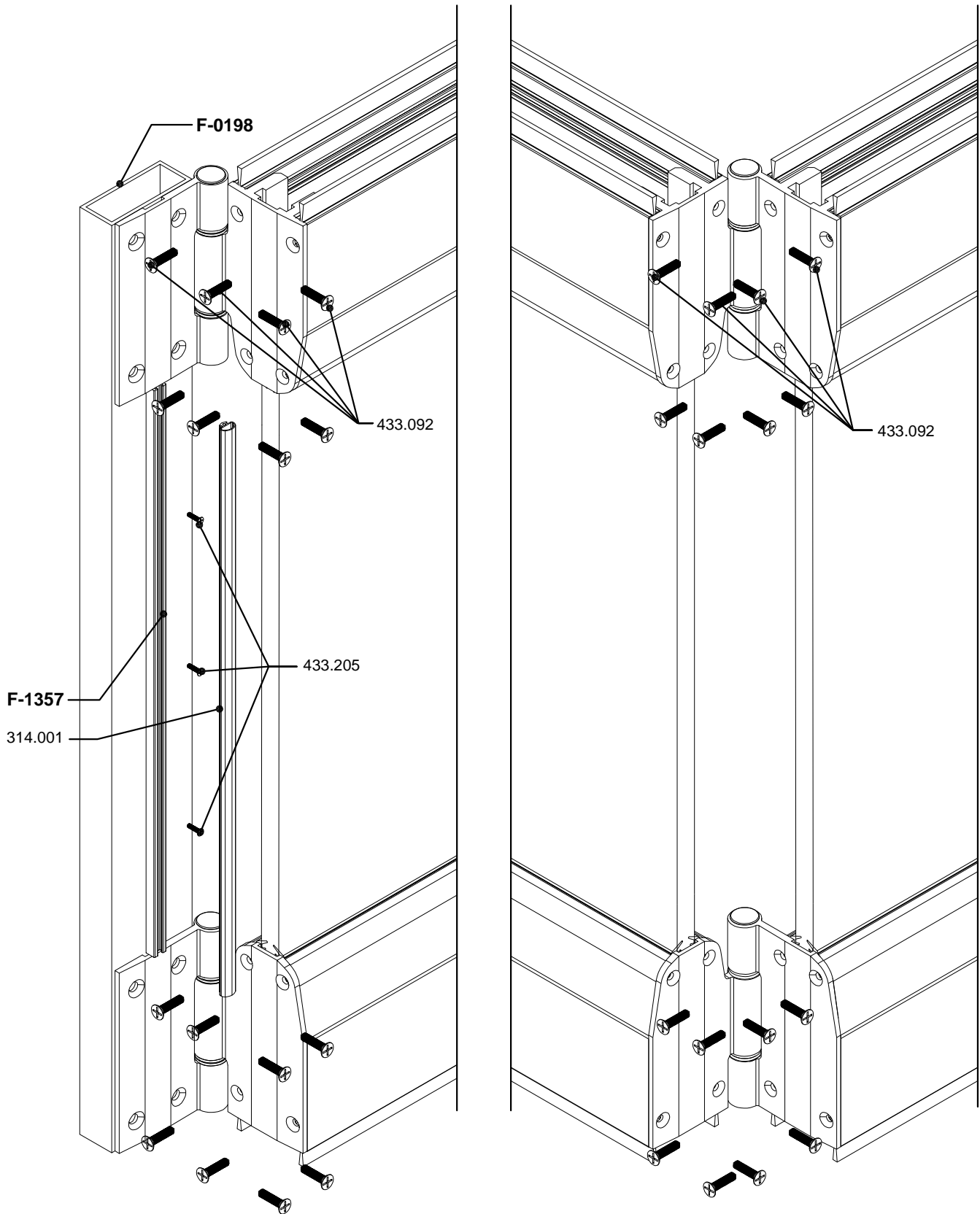

Obrada stakla za bravu 120.008 i prihvatnik brave 120.010

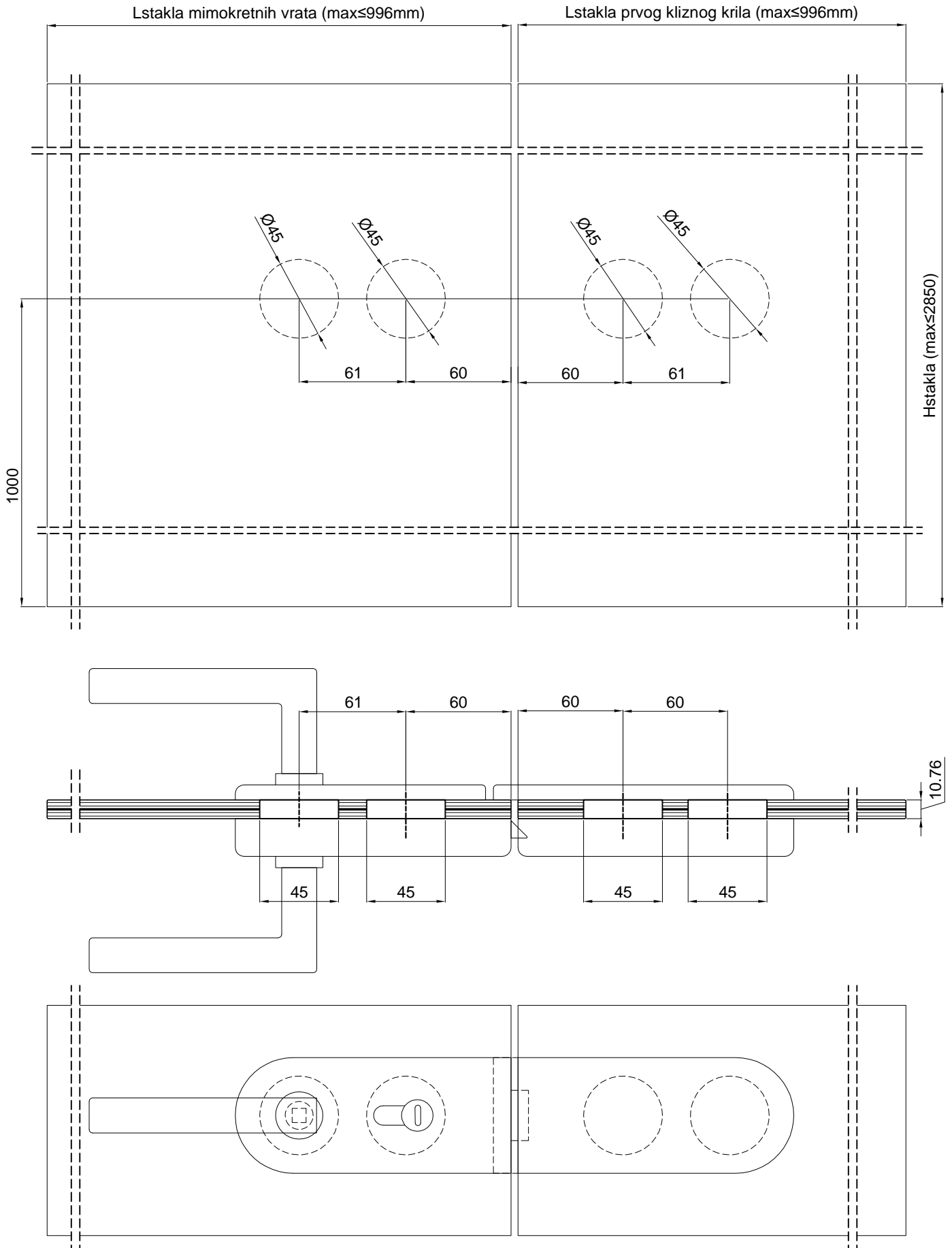

Obrada stakla za bravu 120.008 i mali prihvatnik brave 120.011

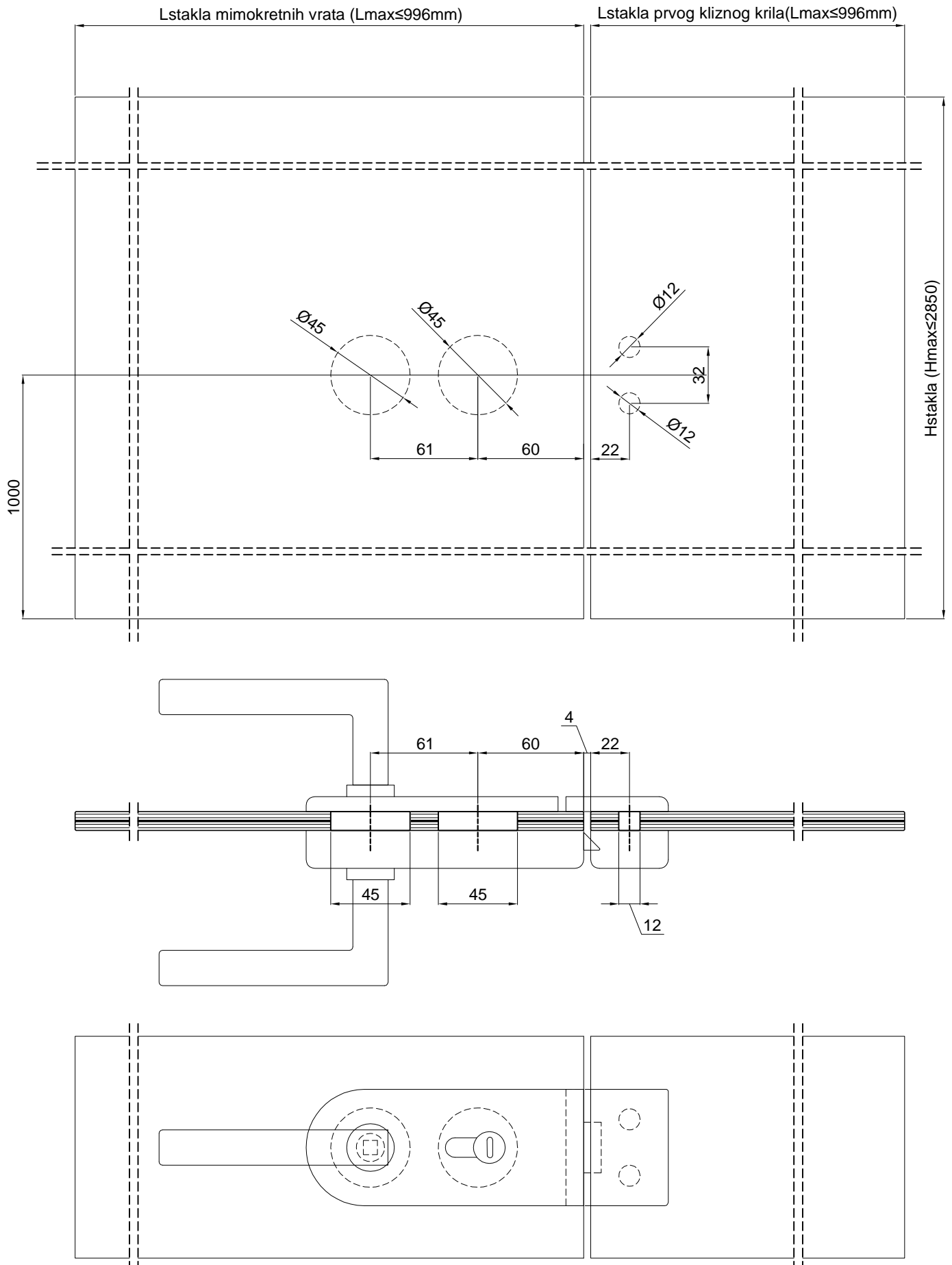

Obrada stakla za sigurnosni držač

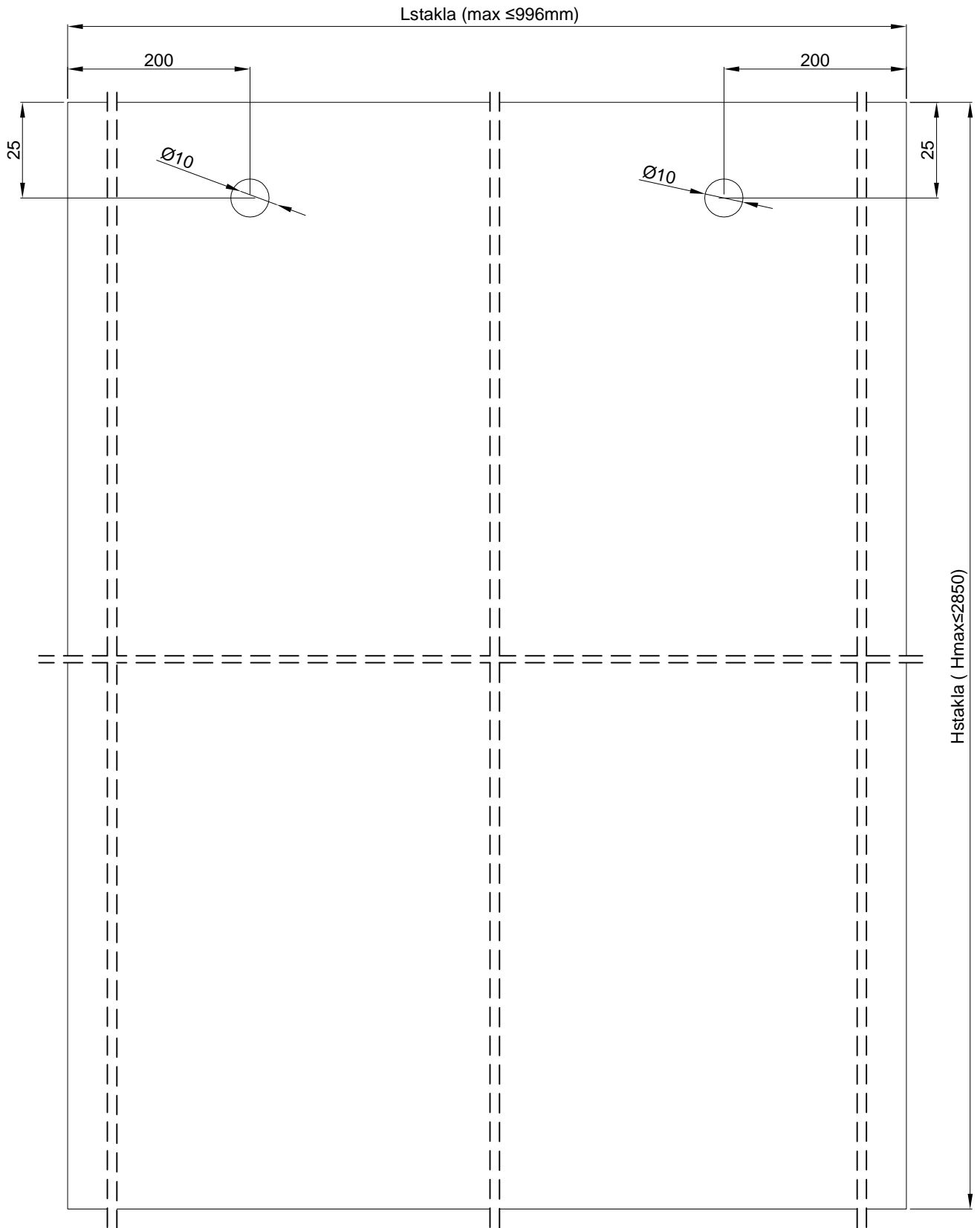

Obrada stakla za ručku za staklena vrata 100.013

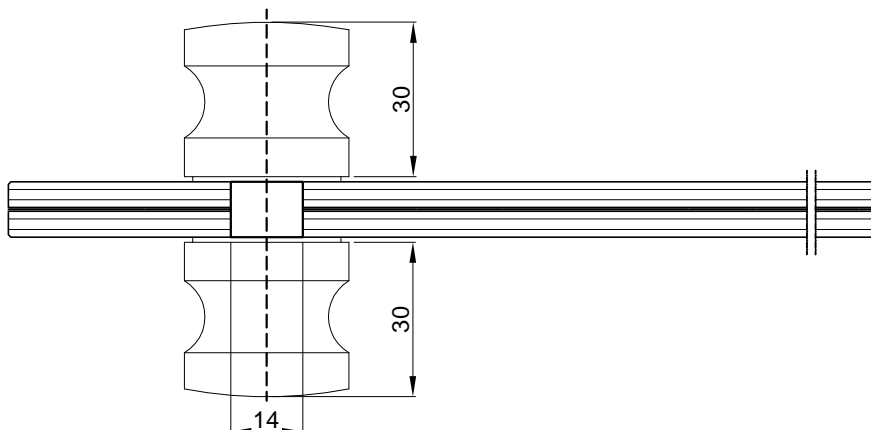
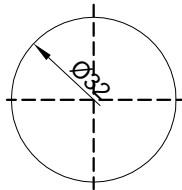
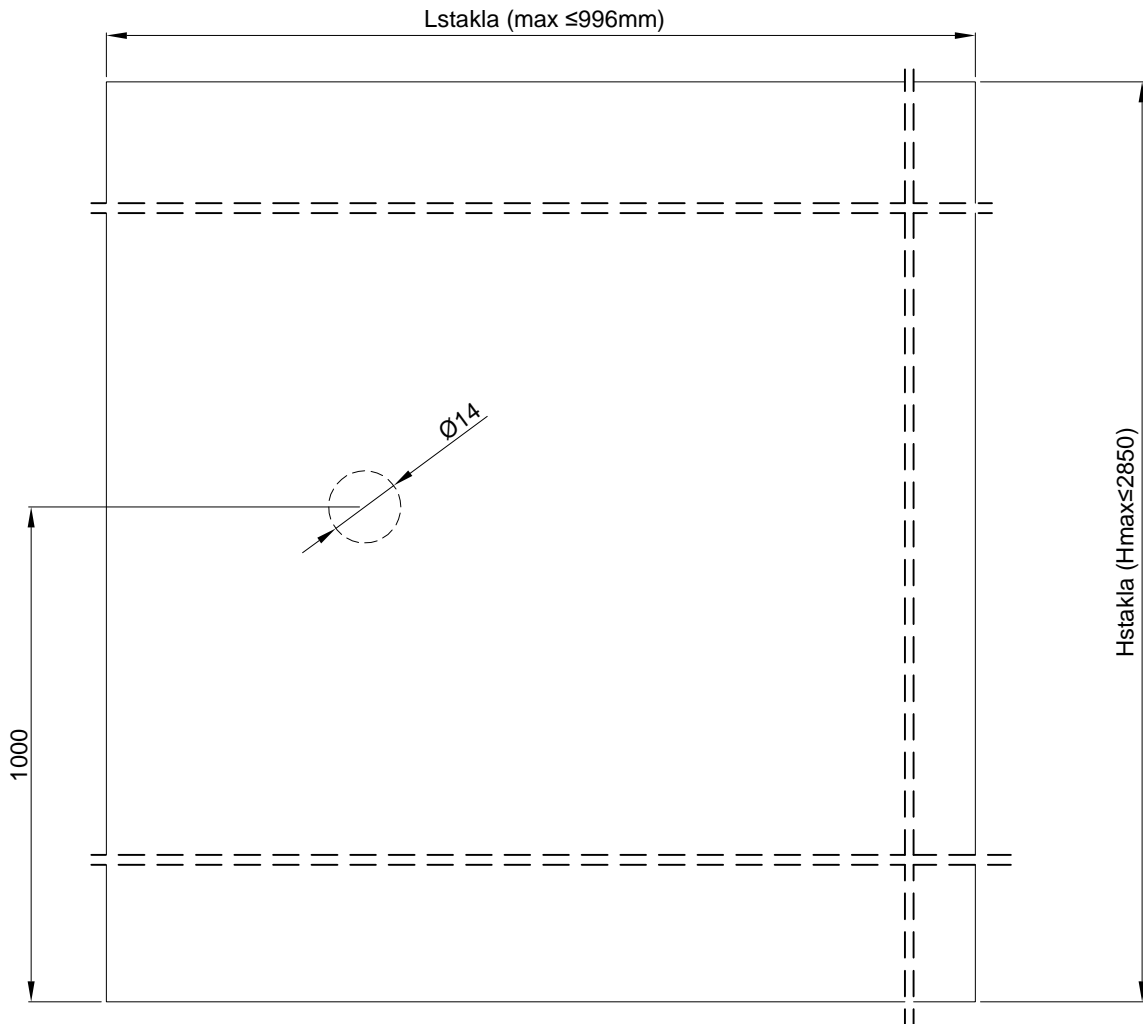

Rezne liste

Izračun dimenzija mimokretnog krila

naziv	mjera	kom.	pilanje
Profili			
F-1472 Lkrila-7.5	4	90-90
F-1473 Lkrila-7.5	4	90-90
F-0021 Lkrila-7.5	2	90-90
Brtve			
Brtva u stopi 344.070 Lkrila-7.5	2	
Brtva na stakla 311.001 Lkrila-7.5	4	
Četkasta brtva prema stropu 347.008 Lkrila-7.5	2	
Četkasta brtva prema podu 347.010 Lkrila-7.5	2	
Okovi i vijci			
Vijak	431.914	8 komada
Podloška	432.128/	32 komada
Matica	432.013	8 komada
Set čepova zaokretnog krila 301.039	1 komad
Brava	120.008	1 komad
Kvake za bravu	120.009	1 komad
Prihvatnik brave	120.010(120.011)	1 komad
Opcija 1)- Automat u podu			
Gornji okov	146.007	1 komad
Automat u podu	146.008	1 komad
Opcija 2)- Automat u krilu			
Gornji okov	146.007	1 komad
Automat u krilu	140.072	1 komad

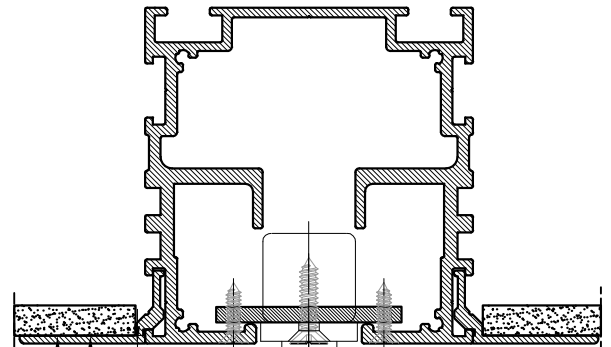
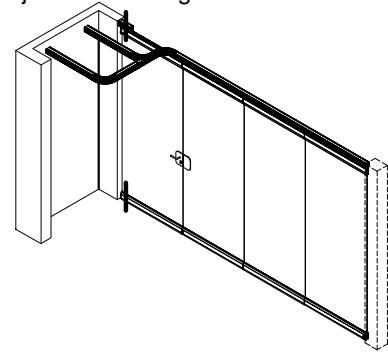

Ostakljenje

Staklo (55.2 mm) (Lkr-4)x(H-150)	1
------------------	-----------------------	---

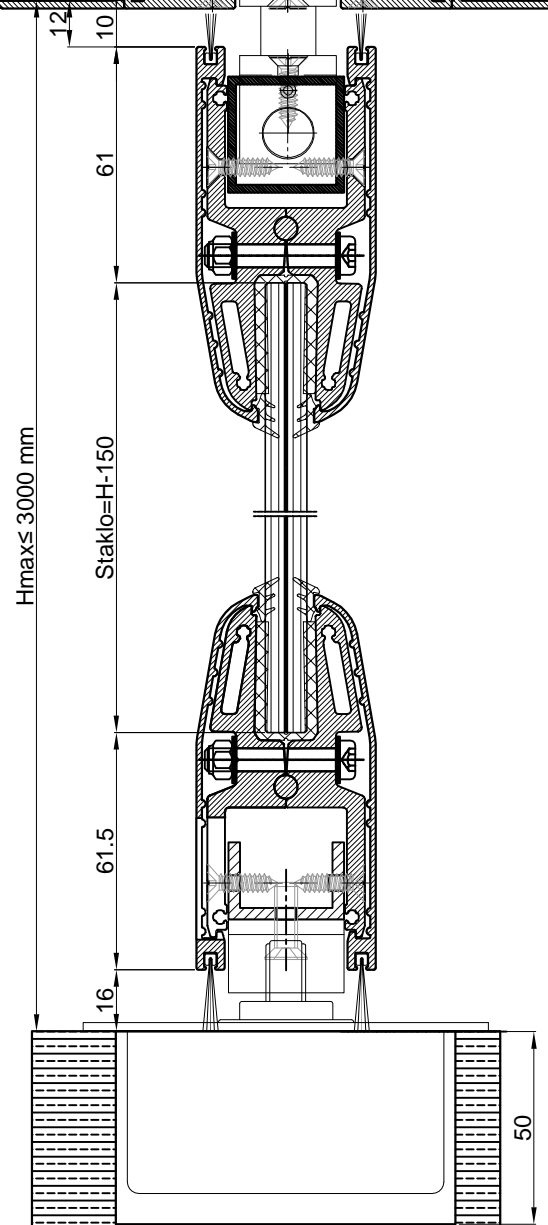
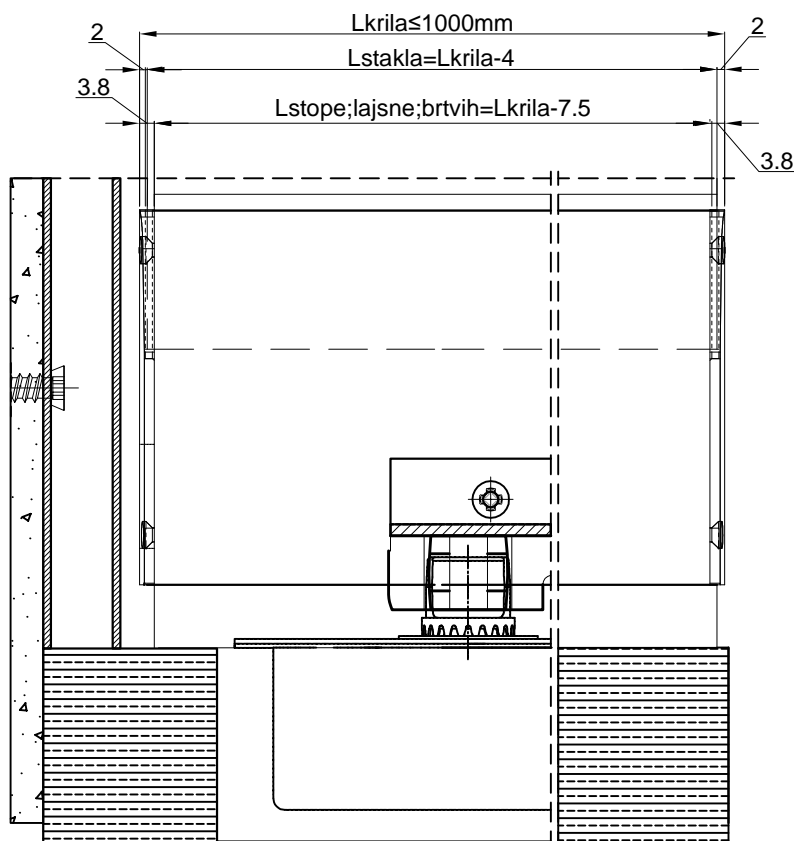

Izračun dimenzija prvog kliznog kliza

naziv	mjera	kom.	pilanje
Profili			
F-1472 Lkrila-7.5	4	90-90
F-1473 Lkrila-7.5	4	90-90
F-0021 Lkrila-7.5	2	90-90
Brtve			
Brtva u stopi 344.070 Lkrila-7.5	2	
Brtva na stakla 311.001 Lkrila-7.5	4	
Četkasta brtva prema stropu 347.008 Lkrila-7.5	2	
Četkasta brtva prema podu 347.010 Lkrila-7.5	2	
Okovi i vijci			
Kotačić kl. krila 521.212	2 komada	
Vijak 431.914	8 komada	
Podloška 432.128	32 komada	
Matica 432.013	8 komada	
Set čepova prvog kliznog krila 301.040	1 komad	
Podna čahura 120.013	1 komad	
Ostakljenje			
Staklo (55.2 mm) (Lkr-4)x(H-150)	1	

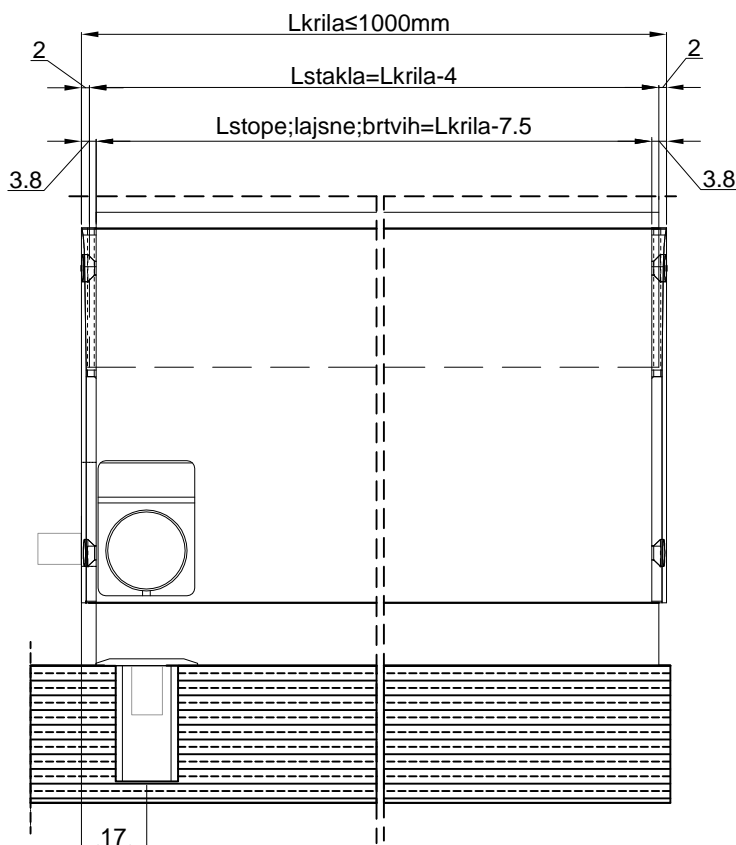
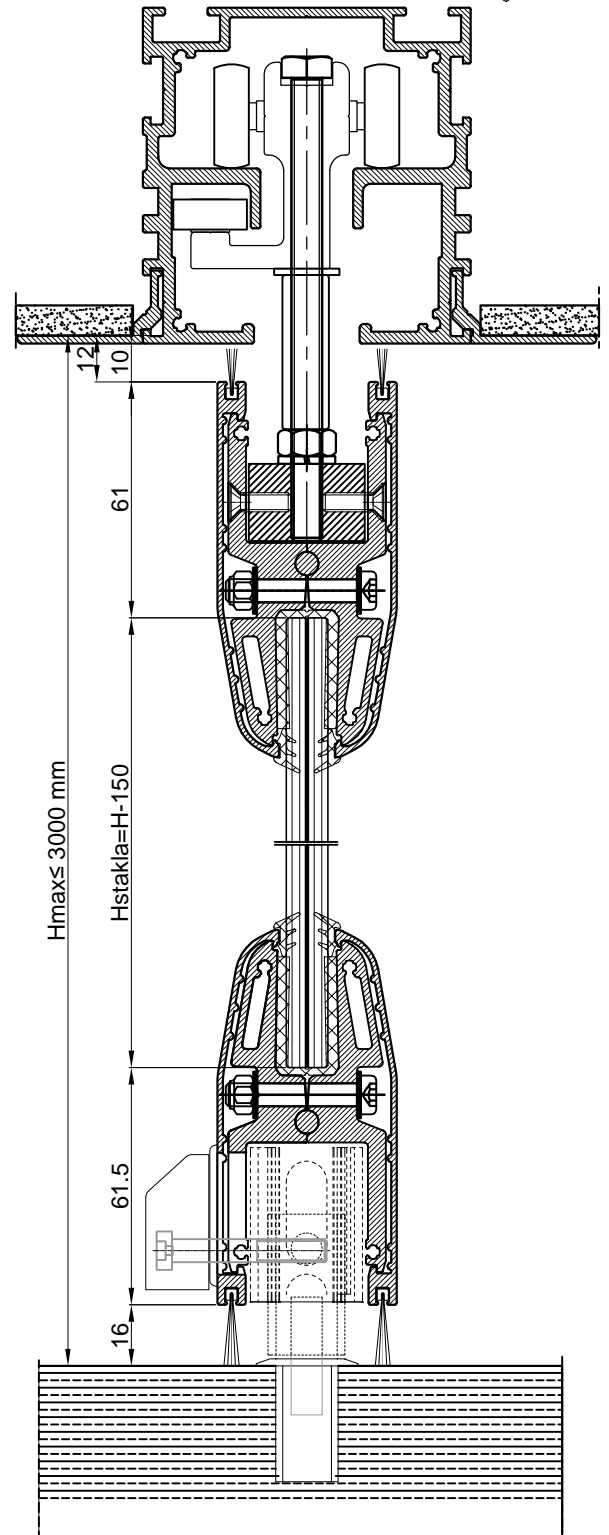
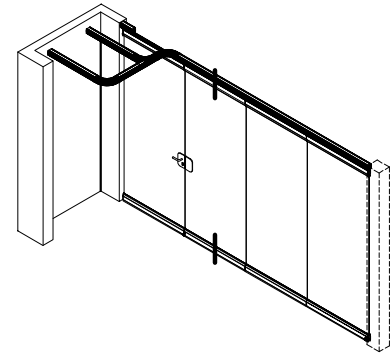

Izračun dimenzija srednjih kliznih krila

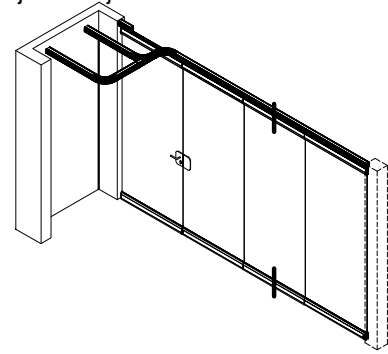

naziv	mjera	kom.	pilanje
Profili			
F-1472 Lkrila-7.5	4	90-90
F-1473 Lkrila-7.5	4	90-90
F-0021 Lkrila-7.5	2	90-90

Brtve

Brtva u stopi 344.070 Lkrila-7.5	2
Brtva na stakla 311.001 Lkrila-7.5	4
Četkasta brtva prema stropu 347.008 Lkrila-7.5	2
Četkasta brtva prema podu 347.010 Lkrila-7.5	2

Okovi i vijci

Kotačić kl. krila 521.212	2 komada
Vijak 431.914	8 komada
Podloška 432.128	32 komada
Matica 432.013	8 komada
Set čepova srednjeg kliznog krila 301.041	1 komad
Podna čahura 120.013	1 komad

Ostakljenje

Staklo (55.2 mm) (Lkr-4)x(H-150)	1
------------------	-----------------------	---

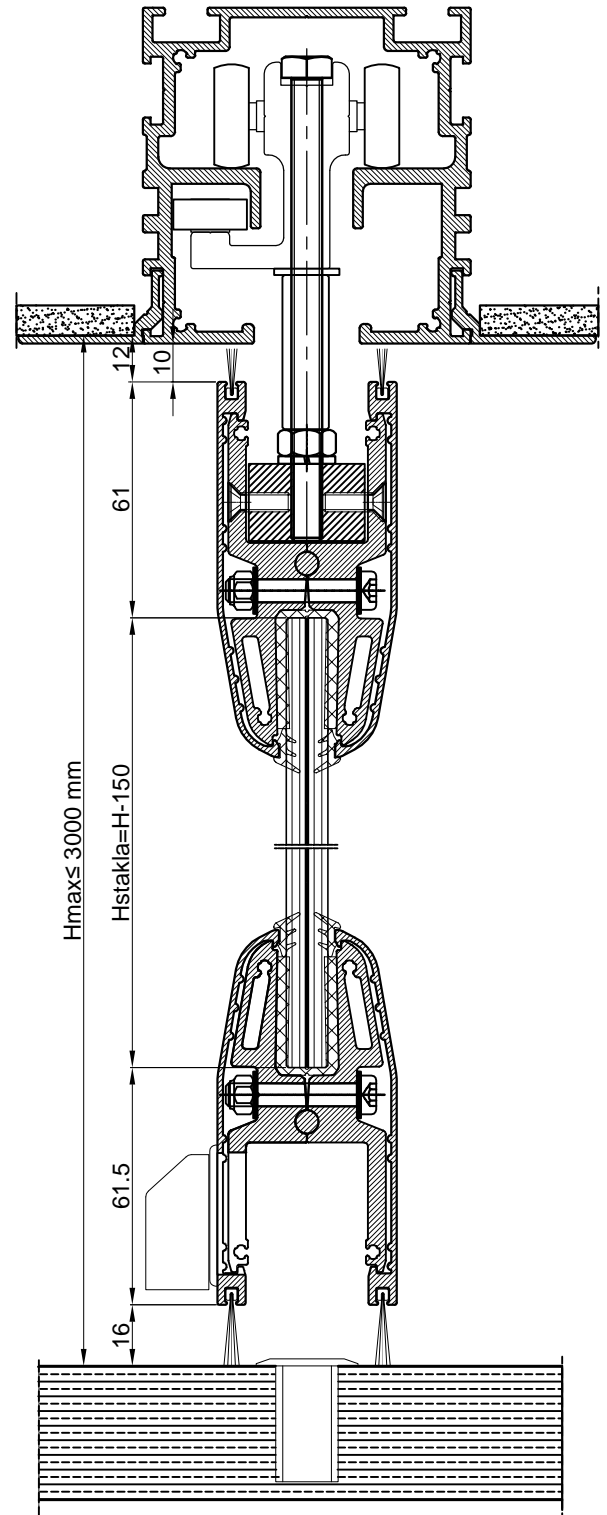
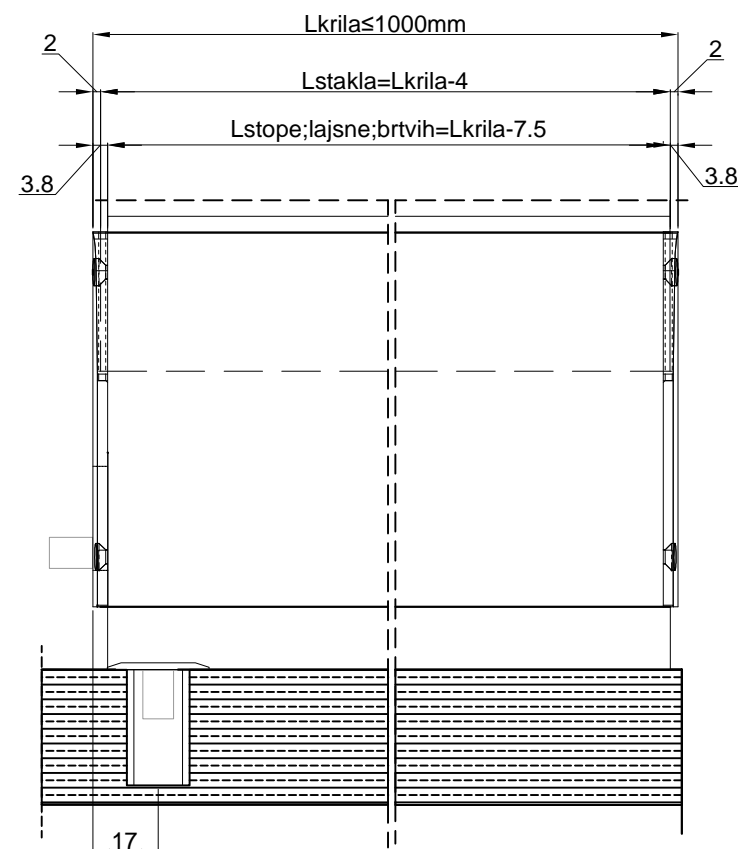

Izračun dimenzija zadnjeg kliznog krila

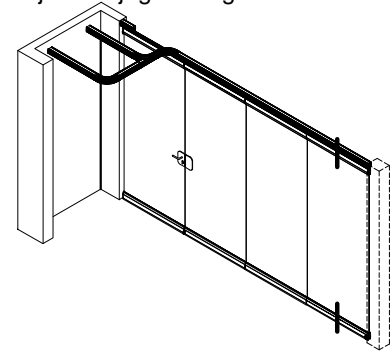

naziv	mjera	kom.	pilanje
Profili			
F-1472 Lkrila-7.5	4	90-90
F-1473 Lkrila-7.5	4	90-90
F-0021 Lkrila-7.5	2	90-90

Brtve

Brtva u stopi 344.070 Lkrila-7.5	2
Brtva na staklu 311.001 Lkrila-7.5	4
Četkasta brtva prema stropu 347.008 Lkrila-7.5	2
Četkasta brtva prema podu 347.010 Lkrila-7.5	2

Okovi i vijci

Kotačić kl. krila 521.212	2 komada
Vijak 431.914	8 komada
Podloška 432.128	32 komada
Matica 432.013	8 komada
Set čepova zadnjeg kliznog krila 301.042	1 komad
Podna čahura 120.013	2 komada

Ostakljenje

Staklo (55.2 mm) (Lkr-4)x(H-150)	1
------------------	-----------------------	---

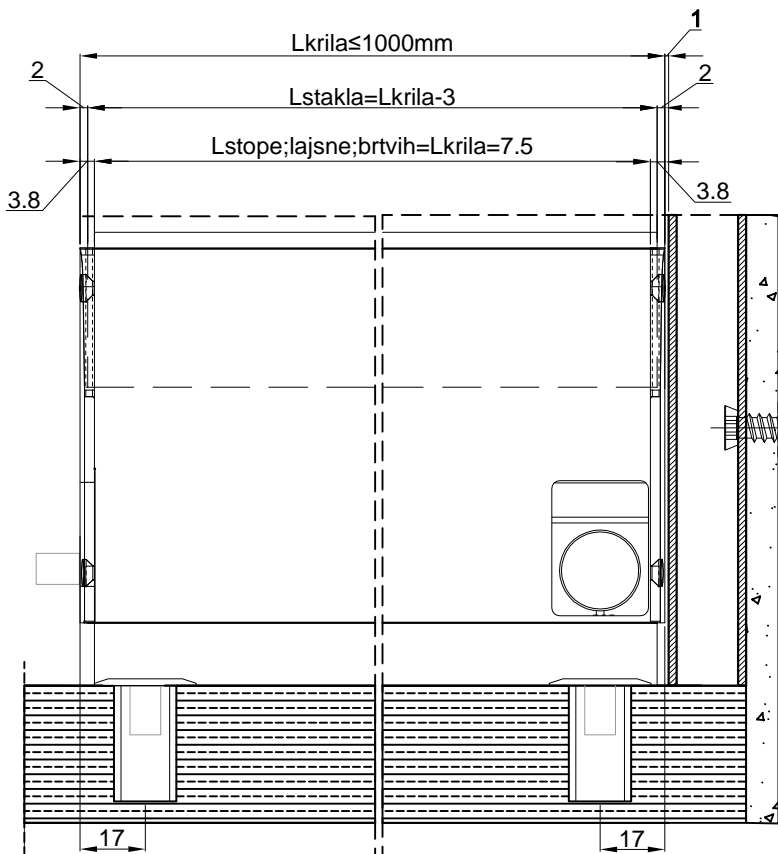
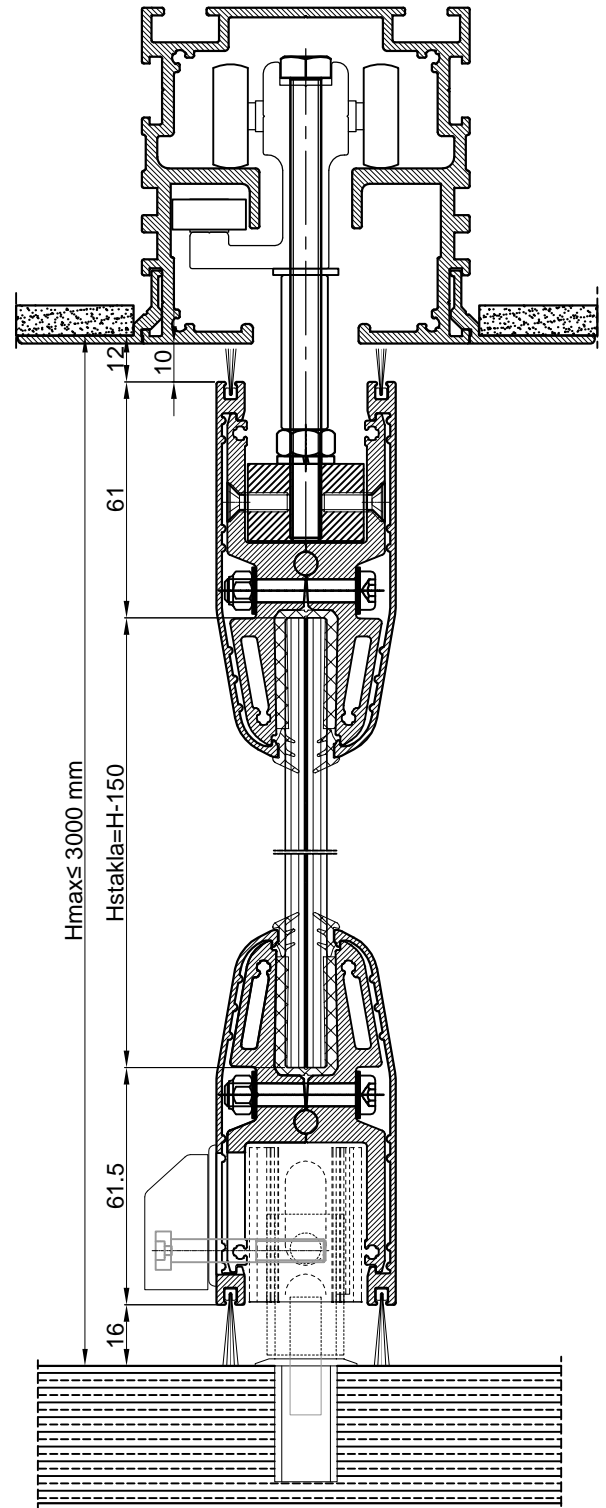

Tipovi otvaranja

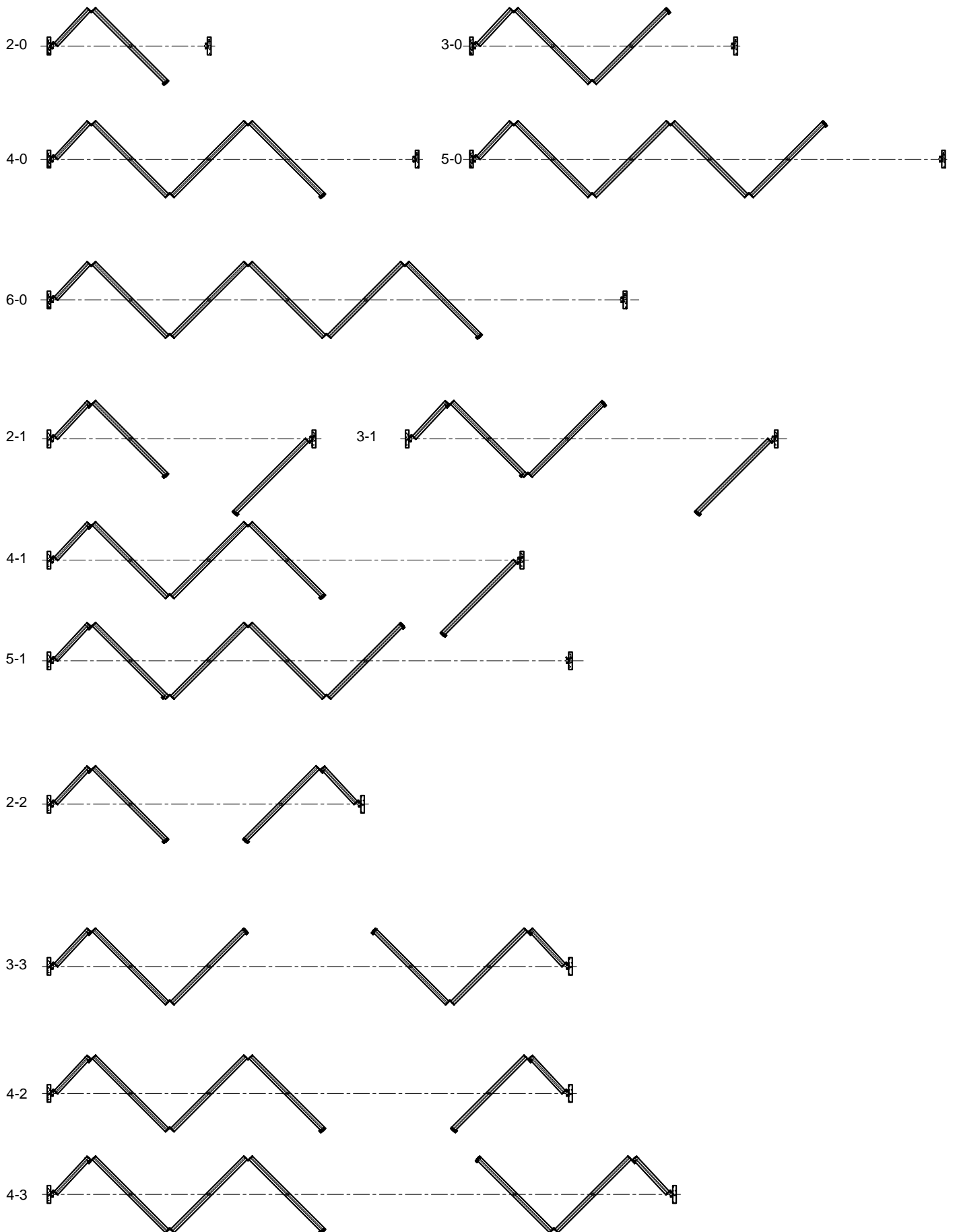

Tip otvaranja 2-0

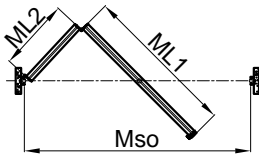
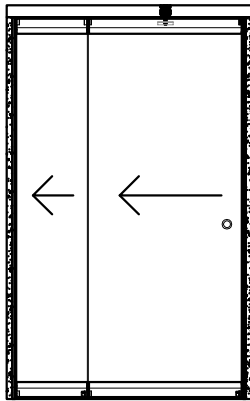

naziv	mjera	kom.	pilanje
Profili			
F-1472	ML1-7.5	4	90-90
F-1472	ML2-7.5	4	90-90
F-1473	ML1-7.5	4	90-90
F-1473	ML2-7.5	4	90-90
F-0021	ML1-7.5	2	90-90
F-0021	ML2-7.5	2	90-90

naziv	mjera	kom.
Brtnice		
Brtnica u stopi 344.070	ML1-7.5	2
Brtnica u stopi 344.070	ML2-7.5	2
Brtnica na staklu 311.001	ML1-7.5	4
Brtnica na staklu 311.001	ML2-7.5	4
Četkasta brtnica prema stropu 347.008	ML1-7.5	2
Četkasta brtnica prema stropu 347.008	ML2-7.5	2
Četkasta brtnica prema podu 347.010	ML1-7.5	2
Četkasta brtnica prema podu 347.010	ML2-7.5	2

Okovi i vijci		
Kotačić kl. krila 140.065	1 komad
Vijak 431.914	12 komada
Podloška 432.128	48 komada
Matica 432.013	12 komada
Čep zatvoreni 301.043	1 komad
Čep s boč. za. 301.044	1 komad
Zidna baglama 111.118	1 komad
Zidna baglama 111.119	1 komad
Baglama 111.120	1 komad
Baglama 111.117	1 komad
Držać krila 724.021(724.022)	2 komada
Ručka za st. vr. 100.013	1 komad
Podna čahura 120.013	2 komada

Ostakljenje		
Staklo1 (55.2 mm)	(ML1-5)x(H-150)	1
Staklo2 (55.2 mm)	(ML2-6)x(H-150)	1

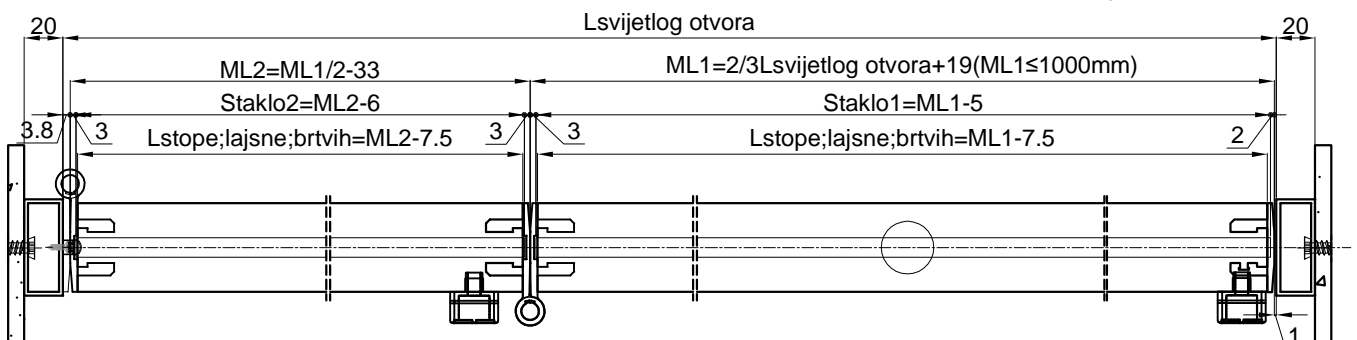
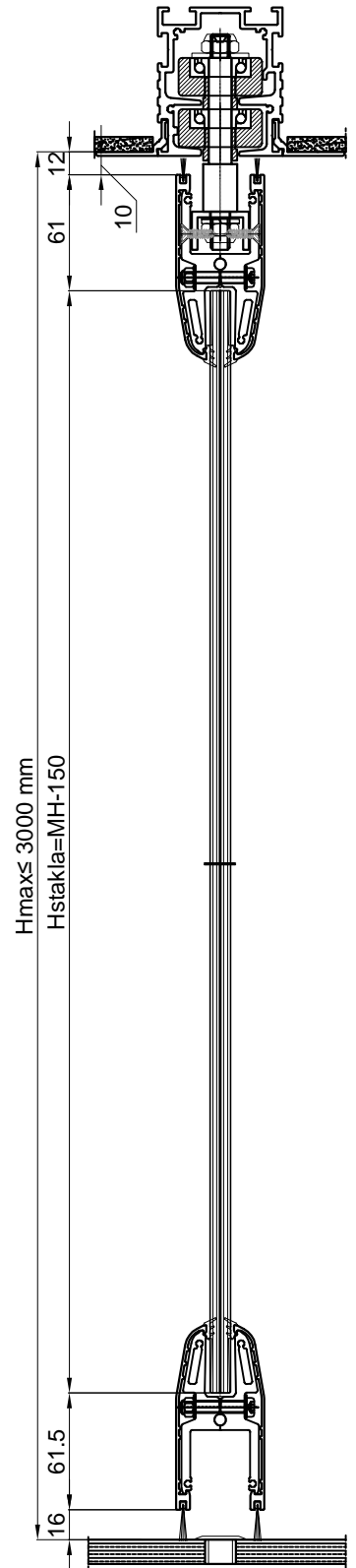

Tip otvaranja 3-0

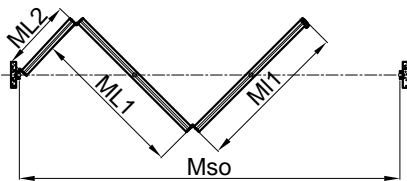
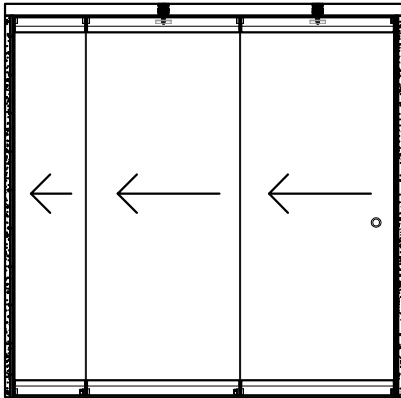

naziv	mjera	kom.	pilanje
Profili			
F-1472	ML1-7.5	8	90-90
F-1472	ML2-7.5	4	90-90
F-1473	ML1-7.5	8	90-90
F-1473	ML2-7.5	4	90-90
F-0021	ML1-7.5	4	90-90
F-0021	ML2-7.5	2	90-90

naziv	mjera	kom.
-------	-------	------

Brtve

Brtva u stopi 344.070	ML1-7.5	4
Brtva u stopi 344.070	ML2-7.5	2
Brtva na staklu 311.001	ML1-7.5	8
Brtva na staklu 311.001	ML2-7.5	4
Četkasta brtva prema stropu 347.008	ML1-7.5	4
Četkasta brtva prema stropu 347.008	ML2-7.5	2
Četkasta brtva prema podu 347.010	ML1-7.5	4
Četkasta brtva prema podu 347.010	ML2-7.5	2

Okovi i vijci

Kotačić kl. krila 140.065		2 komada
Vijak 431.914		20 komada
Podloška 432.128		80 komada
Matica 432.013		20 komada
Čep zatvoreni 301.043		1 komad
Čep s boč. za. 301.044		1 komad
Zidna baglama 111.118		1 komad
Zidna baglama 111.119		1 komad
Baglama 111.120		1 komad
Baglama 111.117		1 komad
Baglama 111.121		1 komad
Baglama 111.116		1 komad
Držać krila 724.021(724.022)		4 komada
Ručka za st. vr. 100.013		1 komad
Podna čahura 120.013		3 komada

Ostakljenje

Staklo1 (55.2 mm)	(ML1-5)x(H-150)	1
Staklo2 (55.2 mm)	(ML1-6)x(H-150)	1
Staklo3 (55.2 mm)	(ML2-6)x(H-150)	1

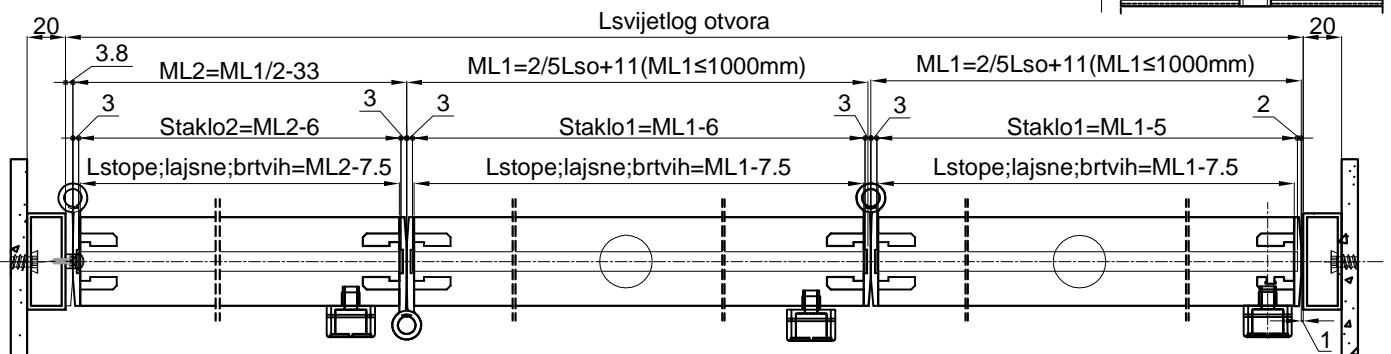
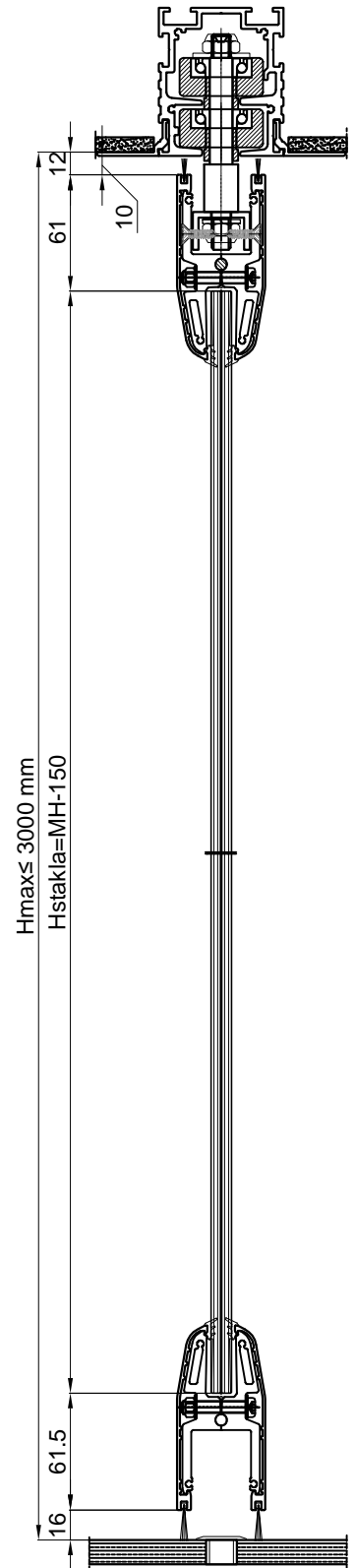

Tip otvaranja 4-0

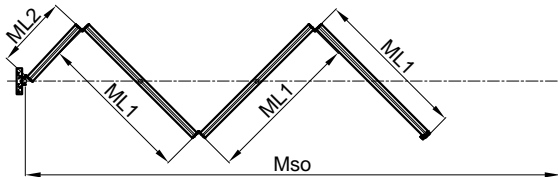
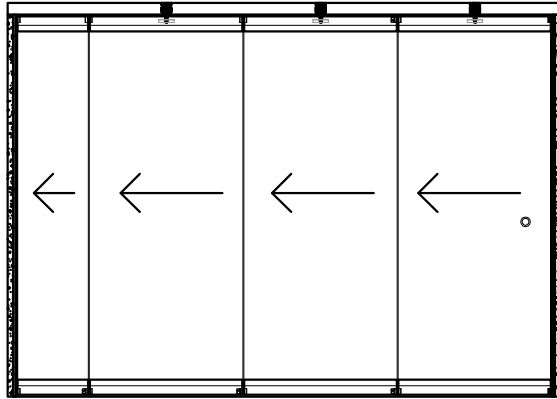

naziv	mjera	kom.	pilanje
Profili			
F-1472	ML1-7.5	12	90-90
F-1472	ML2-7.5	4	90-90
F-1473	ML1-7.5	12	90-90
F-1473	ML2-7.5	4	90-90
F-0021	ML1-7.5	6	90-90
F-0021	ML2-7.5	2	90-90

naziv	mjera	kom.
Brtve		
Brtva u stopi 344.070	ML1-7.5	6
Brtva u stopi 344.070	ML2-7.5	2
Brtva na staklu 311.001	ML1-7.5	12
Brtva na staklu 311.001	ML2-7.5	4
Četkasta brtva prema stropu 347.008	ML1-7.5	6
Četkasta brtva prema stropu 347.008	ML2-7.5	2
Četkasta brtva prema podu 347.010	ML1-7.5	6
Četkasta brtva prema podu 347.010	ML2-7.5	2

Okovi i vijci		
Kotačić kl. krila	140.065	3 komad
Vijak	431.914	28 komada
Podloška	432.128	112 komada
Matica	432.013	28 komada
Čep zatvoreni	301.043	1 komad
Čep s boč. za.	301.044	1 komad
Zidna baglama	111.118	1 komad
Zidna baglama	111.119	1 komad
Baglama	111.120	2 komad
Baglama	111.117	2 komad
Baglama	111.121	1 komad
Baglama	111.116	1 komad
Držać krila	724.021(724.022)	6 komada
Ručka za st. vr.	100.013	1 komad
Podna čahura	120.013	3 komada

Ostakljenje		
Staklo1 (55.2 mm)	(ML1-5)x(H-150)	1
Staklo2 (55.2 mm)	(ML1-6)x(H-150)	2
Staklo3 (55.2 mm)	(ML2-6)x(H-150)	1

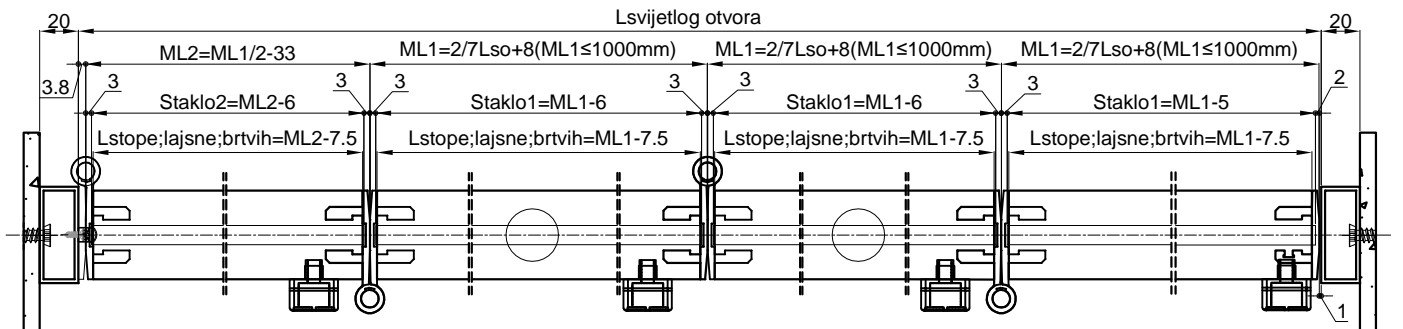
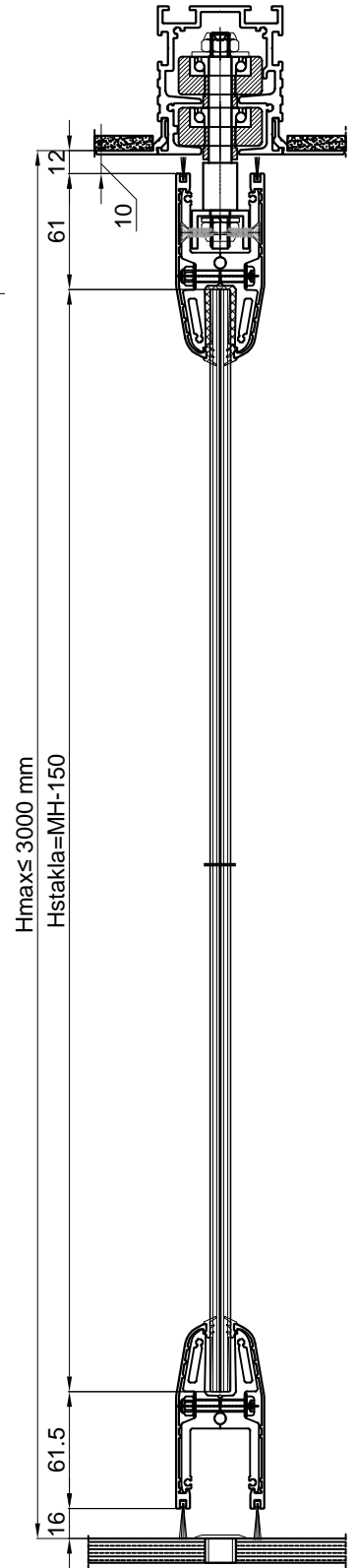

Tip otvaranja 2-1

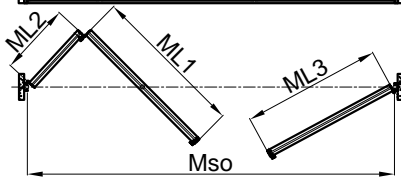
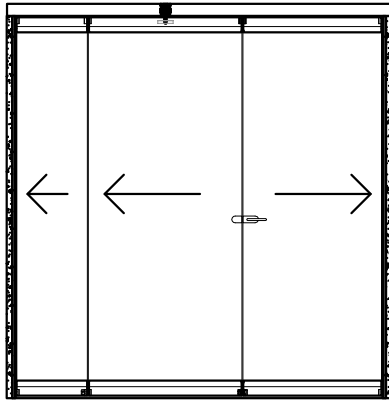

naziv	mjera	kom.	pilanje
Profili			
F-1472	ML1-7.5	4	90-90
F-1472	ML2-7.5	4	90-90
F-1472	ML3-7.5	4	90-90
F-1473	ML1-7.5	4	90-90
F-1473	ML2-7.5	4	90-90
F-1473	ML3-7.5	4	90-90
F-0021	ML1-7.5	2	90-90
F-0021	ML2-7.5	2	90-90
F-0021	ML3-7.5	2	90-90

naziv	mjera	kom.
-------	-------	------

Brtve

Brтва u stopi 344.070	ML1-7.5	2
Brтва u stopi 344.070	ML2-7.5	2
Brтва u stopi 344.070	ML3-7.5	2
Brтва na staklu 311.001	ML1-7.5	4
Brтва na staklu 311.001	ML2-7.5	4
Brтва na staklu 311.001	ML3-7.5	4
Četkasta brtva prema stropu 347.008	ML1-7.5	2
Četkasta brtva prema stropu 347.008	ML2-7.5	2
Četkasta brtva prema stropu 347.008	ML3-7.5	2
Četkasta brtva prema podu 347.010	ML1-7.5	2
Četkasta brtva prema podu 347.010	ML2-7.5	2
Četkasta brtva prema podu 347.010	ML3-7.5	2

Okovi i vijci

Kotačić kl. krila 140.065	1 komad
Vijak 431.914	20 komada
Podloška 432.128	80 komada
Matica 432.013	20 komada
Čep zatvoreni 301.043	3 komad
Čep s boč. za. 301.044	1 komad
Zidna baglama 111.118	2 komad
Zidna baglama 111.119	2 komad
Baglama 111.120	1 komad
Baglama 111.117	1 komad
Držac krila 724.021(724.022)	2 komada
Brava 120.008	1 komad
Kvake za bravu 120.009	1 komad
Prihvatnik brave 120.010(120.011)	1 komad
Podna čahura 120.013	2 komada

Ostakljenje

Staklo1 (55.2 mm)	(ML1-5)x(H-150)	1
Staklo2 (55.2 mm)	(ML2-6)x(H-150)	1
Staklo3 (55.2 mm)	(ML3-5)x(H-150)	1

Lsvijetlog otvora

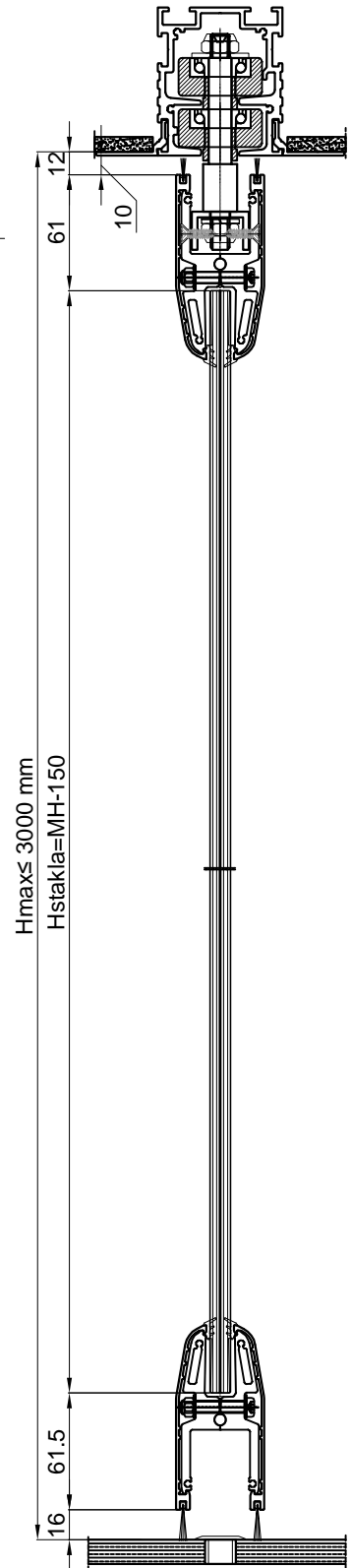
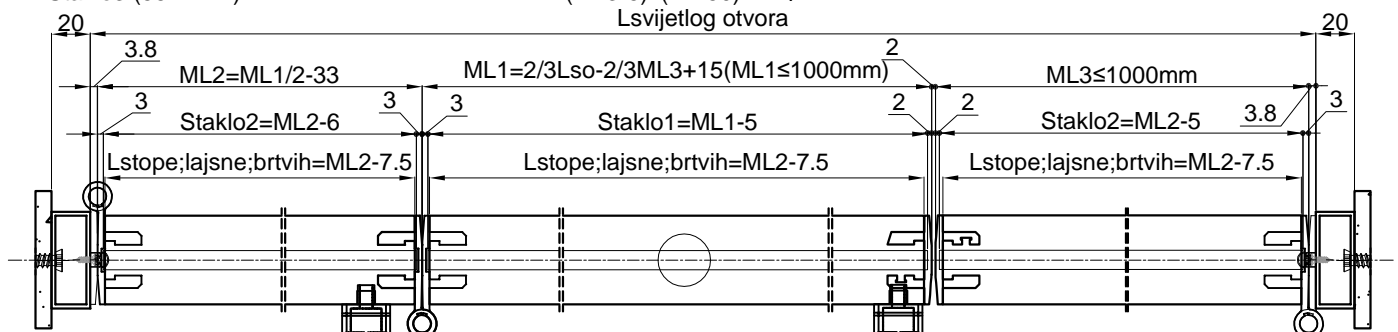

Tip otvaranja 3-1

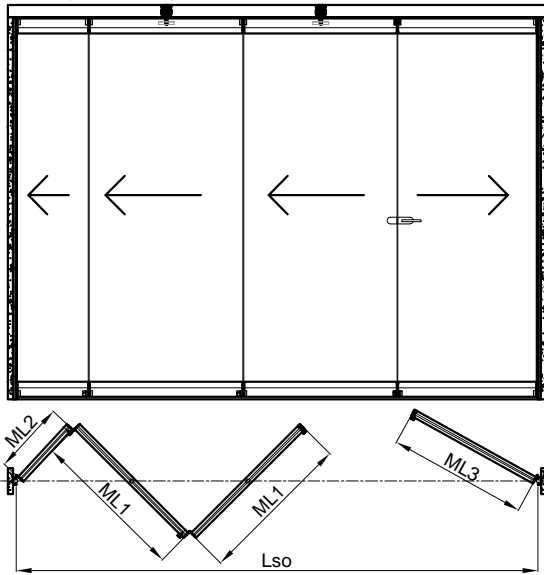

naziv	mjera	kom.	pilanje
Profili			
F-1472	ML1-7.5	8	90-90
F-1472	ML2-7.5	4	90-90
F-1472	ML3-7.5	4	90-90
F-1473	ML1-7.5	8	90-90
F-1473	ML2-7.5	4	90-90
F-1473	ML3-7.5	4	90-90
F-0021	ML1-7.5	4	90-90
F-0021	ML2-7.5	2	90-90
F-0021	ML3-7.5	2	90-90

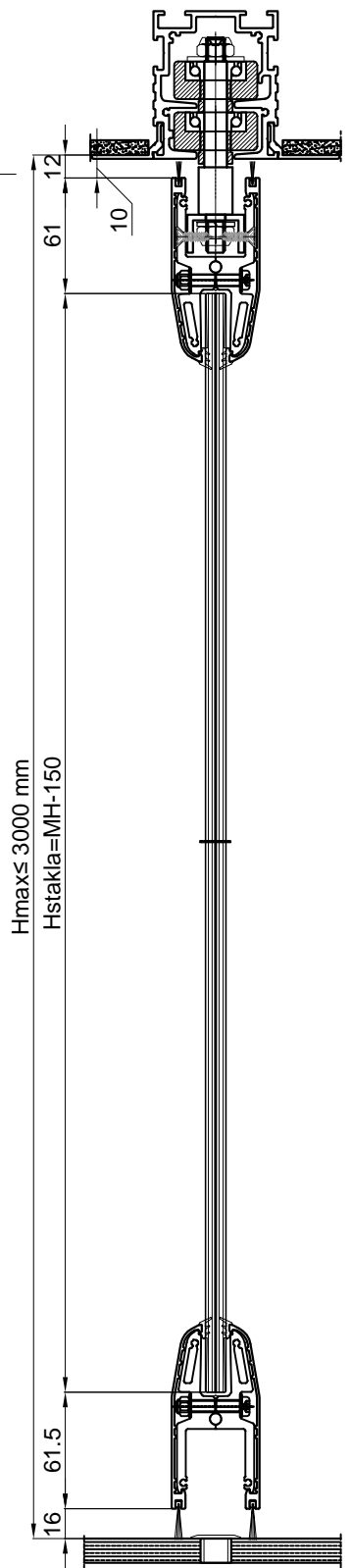

naziv	mjera	kom.
Brtve		
Brtva u stopi 344.070	ML1-7.5	2
Brtva u stopi 344.070	ML2-7.5	4
Brtva u stopi 344.070	ML3-7.5	2
Brtva na staklu 311.001	ML1-7.5	4
Brtva na staklu 311.001	ML2-7.5	8
Brtva na staklu 311.001	ML3-7.5	4
Četkasta brtva prema stropu 347.008	ML1-7.5	2
Četkasta brtva prema stropu 347.008	ML2-7.5	4
Četkasta brtva prema stropu 347.008	ML3-7.5	2
Četkasta brtva prema podu 347.010	ML1-7.5	2
Četkasta brtva prema podu 347.010	ML2-7.5	4
Četkasta brtva prema podu 347.010	ML3-7.5	2

Okovi i vijci		
Kotačić kl. krila 140.065		2 komad
Vijak 431.914		28 komada
Podloška 432.128		112 komada
Matica 432.013		28 komada
Čep zatvoreni 301.043		3 komada
Čep s boč. za. 301.044		1 komad
Zidna baglama 111.118		2 komada
Zidna baglama 111.119		2 komada
Baglama 111.120		1 komad
Baglama 111.117		1 komad
Baglama 111.121		1 komad
Baglama 111.116		1 komad
Podna čahura 120.013		3 komada
Držać krila 724.021(724.022)		4 komada
Brava 120.008		1 komad
Kvake za bravu 120.009		1 komad
Prihvatnik brave 120.010(120.011)		1 komad

Ostakljenje		
Staklo1 (55.2 mm)	(ML2-6)x(H-150)	1
Staklo2 (55.2 mm)	(ML1-6)x(H-150)	1
Staklo3 (55.2 mm)	(ML1-5)x(H-150)	1
Staklo4 (55.2 mm)	(ML3-5)x(H-150)	1

Lsvijetlog otvora

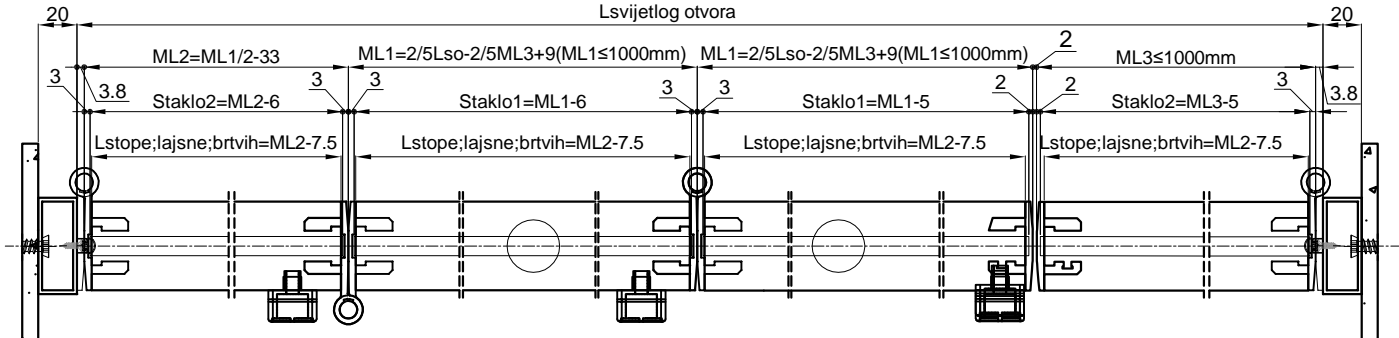

Tip otvaranja 2-2

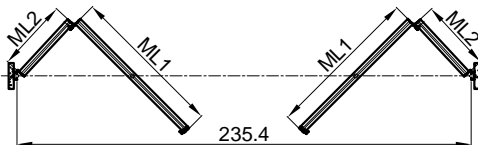
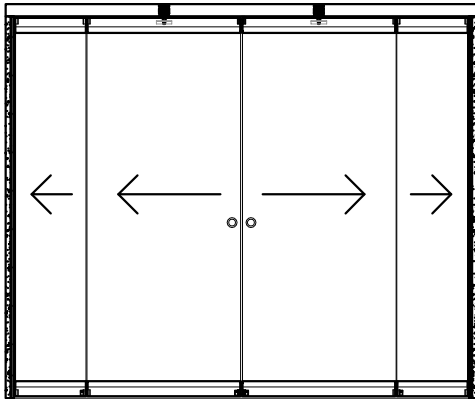

naziv	mjera	kom.	pilanje
Profili			
F-1472	ML1-7.5	8	90-90
F-1472	ML2-7.5	8	90-90
F-1473	ML1-7.5	8	90-90
F-1473	ML2-7.5	8	90-90
F-0021	ML1-7.5	4	90-90
F-0021	ML2-7.5	4	90-90

naziv	mjera	kom.
Brtve		
Brtva u stopi 344.070	ML1-7.5	4
Brtva u stopi 344.070	ML2-7.5	4
Brtva na staklu 311.001	ML1-7.5	8
Brtva na staklu 311.001	ML2-7.5	8
Četkasta brtva prema stropu 347.008	ML1-7.5	4
Četkasta brtva prema stropu 347.008	ML2-7.5	4
Četkasta brtva prema podu 347.010	ML1-7.5	4
Četkasta brtva prema podu 347.010	ML2-7.5	4

Okovi i vijci

Kotačić kl. krila 140.065	2 komad
Vijak 431.914	24 komada
Podloška 432.128	96 komada
Matica 432.013	24 komada
Čep zatvoreni 301.043	2 komada
Čep s boč. za. 301.044	2 komada
Zidna baglama 111.118	2 komad
Zidna baglama 111.119	2 komad
Baglama 111.120	1 komad
Baglama 111.117	1 komad
Baglama 111.121	1 komad
Baglama 111.116	1 komad
Držać krila 724.021(724.022)	4 komada
Ručka za st. vr. 100.013	2 komada
Podna čahura 120.013	4 komada

Ostakljenje

Staklo1 (55.2 mm)	(ML1-5)x(H-150)	2
Staklo2 (55.2 mm)	(ML2-6)x(H-150)	2

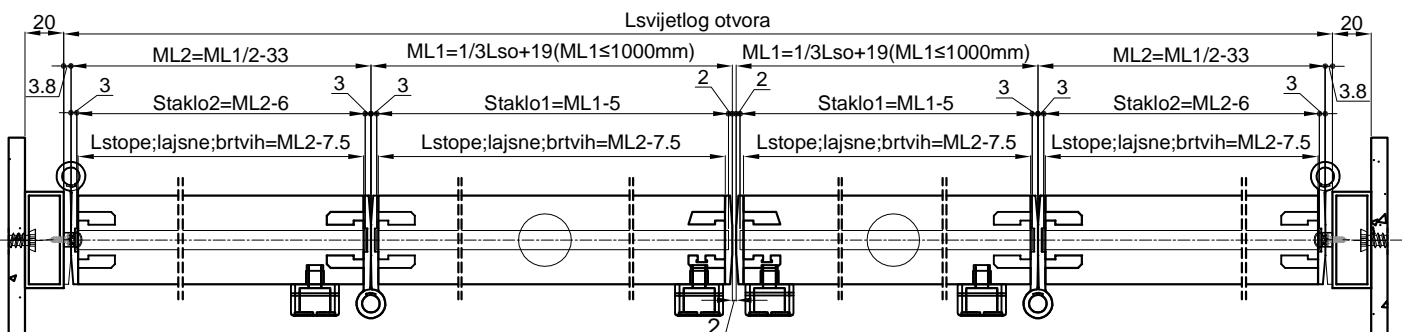
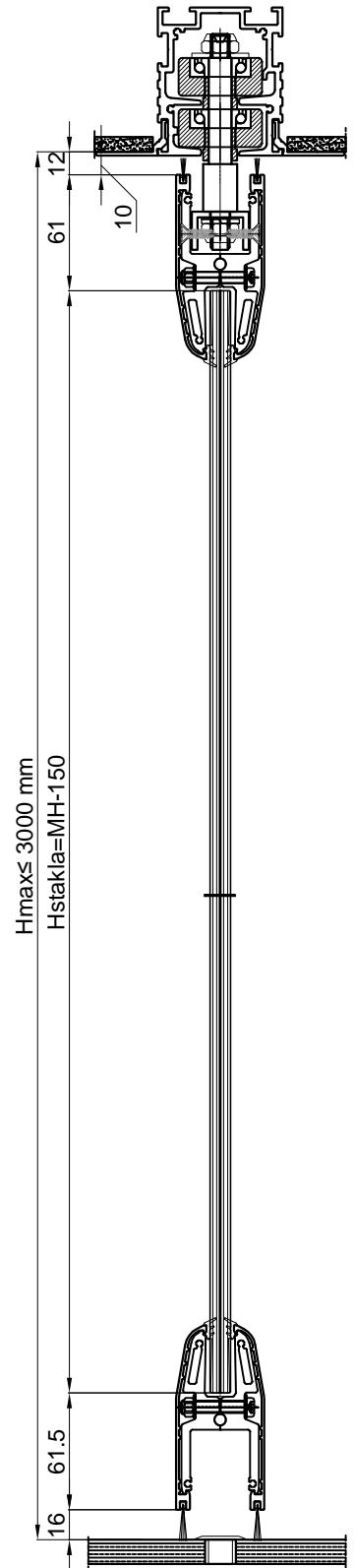

FEAL

MF-45

Veljača 2020. / *February 2020*

FEAL d.o.o.
Trnska cesta 146
88220 Široki Brijeg
Bosna i Hercegovina
Tel. +387 39 704-269; 705-807; 705-636
Fax. +387 39 704-358
info@feal.ba
www.feal.ba